

SERVICE MANUAL

Finisher and Hole Punch Unit

General Precautions for Installation/Service/Maintenance for the Finisher and Hole Punch Unit

The installation and service should be done by a qualified service technician.

1. When installing the Finisher and Hole punch unit to the equipment, be sure to follow the instructions described in the "Unpacking/Set-Up Procedure booklet which comes with each unit.
2. The Finisher and Hole punch unit should be installed by an authorized/qualified person.
3. Before starting installation, servicing or maintenance work, be sure to turn off and unplug the equipment first.
4. When servicing the machines with the power turned ON, be sure not touch live sections and rotating/operating sections.
5. When selecting the installation site, avoid placing the finisher and equipment on different levels or inclined floors.
6. When servicing or maintaining the finisher and hole punch unit be careful about the rotating or operation sections such as gears, pulleys, sprockets, cams, belts, etc.
7. When parts are disassembled, reassembly is basically the reverse of disassembly unless otherwise noted in this manual or other related materials. Be careful not to reassemble small parts such as screws, washers, pins, E-rings, toothed washers to the wrong places.
8. Basically, the machine should not be operated with any parts removed or disassembled.
9. Delicate parts for preventing safety hazard problems (such as breakers, thermofuses, fuses, door switches, sensors, etc. if any) should be handled/installed/adjusted correctly.
10. Use suitable measuring instruments and tools.
11. During servicing or maintenance work, be sure to check the serial No. plate and other cautionary labels (if any) to see if they are clean and firmly fixed. If not, take appropriate actions.
12. The PC board must be stored in an anti-electrostatic bag and handled carefully using a wristband, because the ICs on it may be damaged due to static electricity. Before using the wrist band, pull out the power cord plug of the equipment and make sure that there is no uninsulated charged objects in the vicinity.
13. For the recovery and disposal of used finisher and hole punch unit consumable parts and packing materials, it is recommended that the relevant local regulations/rules.
14. After completing installation, servicing and maintenance of the finisher and hole punch unit, return the finisher and hole punch unit to its original state, and check operation.

15. When you move the finisher, do not move it in the direction of the arrow as shown in the figure [A] below otherwise it might fall down.

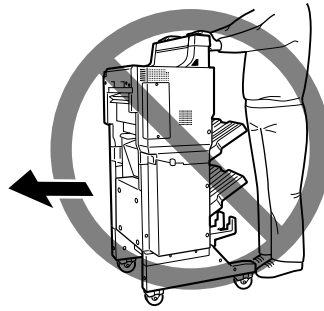

[A]

INTRODUCTION

This Service Manual contains the basic data and figures for the Finisher and Saddle Finisher needed to service the machine in the field.

This manual comprises the following chapters:

- Chapter 1 “General Description” introduces the finisher’s features, specifications, and names of parts, and shows how to operate the finisher.
- Chapter 2 “Finisher Unit Basic Operation” discusses the principles of operation used for the finisher mechanical and electrical systems. It also explains the timing at which these systems are operated.
- Chapter 3 “Saddle Stitcher Unit Basic Operation” discusses the principles of operation used for the saddle stitcher unit’s mechanical and electrical systems. It also explains the timing at which these systems are operated.
- Chapter 4 “Puncher (option) Unit Basic Operation” discusses the principles of operation used for the puncher unit’s mechanical and electrical systems. It also explains the timing at which these systems are operated.
- Chapter 5 “Mechanical System” discusses how the finisher is constructed mechanically, and shows how it may be disassembled/assembled and adjusted.
- Chapter 6 “Maintenance and Inspection” provides tables of periodically replaced parts and consumables and durables, together with a scheduled servicing chart.
- Chapter 7 “Troubleshooting” shows how to troubleshoot possible faults and gives electrical parts arrangement diagrams, LED/check pin diagrams by PCB.

“Appendix” contains diagrams showing tables of signals, overall circuit diagrams and tables of solvents/oils.

Descriptions of installation are not mentioned in this Service Manual as the Finisher/Saddle Finisher’s packing boxes contain Installation Procedures.

The descriptions in this Service Manual are subject to change without notice for product improvement or other purposes, and major changes will be communicated in the form of Service Information bulletins.

All service persons are expected to have a good understanding of the contents of this Service Manual and all relevant Service Information bulletins, and be able to identify and isolate faults in the machine.

CONTENTS

CHAPTER 1 GENERAL DESCRIPTION

I. FEATURES	1-1	E. Supplying the Saddle Stitcher Unit with Staples (Saddle Finisher)	1-18
II. SPECIFICATIONS	1-2	F. Removing Staple Jams from the Saddle Stitcher Unit (Saddle Finisher)	1-19
A. Specifications	1-2	G. Removing Paper Jams from the Puncher Unit (option)	1-21
B. Cross Section	1-9	H. Removing Punched Scrap from the Puncher Unit (option)	1-22
III. Using the Machine	1-12	IV. MAINTENANCE BY THE USER	1-23
A. Removing Paper Jams from the Finisher Unit	1-12	A. Maintenance by the User	1-23
B. Supplying the Finisher Unit with Staples	1-13		
C. Removing Staple Jams from the Finisher Unit	1-15		
D. Removing Paper Jams from the Saddle Stitcher Unit (Saddle Finisher)	1-16		

CHAPTER 2 FINISHER UNIT BASIC OPERATION

I. BASIC OPERATION	2-1	D. Job Offset	2-21
A. Outline	2-1	E. Stapling Operation	2-24
B. Outline of Electrical Circuitry	2-2	F. Stapler Unit	2-32
C. Inputs to and Outputs from the Finisher Controller PCB	2-4	G. Tray Operation	2-38
II. FEED/DRIVE SYSTEM	2-10	H. Detecting the Height of Stack on the Tray	2-40
A. Outline	2-10	I. Shutter Operation	2-42
B. Type of Delivery Paths	2-15	J. Buffer Path Operation	2-46
C. Feeding and Delivering	2-18	K. Detecting Jams	2-51
		III. POWER SUPPLY SYSTEM	2-56

CHAPTER 3 SADDLE STITCHER UNIT

BASIC OPERATION

I. BASIC OPERATION	3-1	C. Controlling the Movement of	
A. Outline	3-1	Sheets	3-21
B. Electrical Circuitry	3-2	D. Aligning the Sheets	3-23
C. Inputs to and Outputs from		E. Controlling the Phase of the	
the Saddle Stitcher Controller		Crescent Roller	3-26
PCB	3-3	IV. STITCHING SYSTEM	3-29
II. FEEDING/DRIVE SYSTEM	3-8	V. FOLDING/DELIVERY	
A. Outline	3-8	SYSTEM	3-32
III. PAPER OUTPUT		VI. CHECKING FOR A JAM	3-40
MECHANISM	3-14	VII. POWER SUPPLY	3-45
A. Outline	3-14		
B. Controlling the Inlet			
Flappers	3-17		

CHAPTER 4 PUNCHER UNIT (OPTION)

BASIC OPERATION

I. BASIC OPERATION	4-1	A. Outline	4-5
A. Outline	4-1	B. PUNCH OPERATION	4-7
B. Inputs to and Outputs from Punch		C. Horizontal Registration	
Driver PCB	4-2	Operation	4-11
II. PUNCH OPERATION	4-5	III. POWER SUPPLY SYSTEM	4-14

CHAPTER 5 MECHANICAL CONSTRUCTION

I. FINISHER UNIT	5-1	B. SADDLE UNIT	5-22
A. Externals and Controls	5-1	C. PCBs	5-32
B. FEEDING SYSTEM	5-8	III. PUNCHER UNIT (OPTION)	5-33
C. PCBs	5-16	A. Externals and Controls	5-33
II. SADDLE STITCHER UNIT	5-17	B. Puncher Driver System	5-34
A. Externals and Controls	5-17	C. PCBs	5-39

CHAPTER 6 MAINTENANCE AND INSPECTION

I. PERIODICALLY REPLACED PARTS	6-1	A. Finisher Unit	6-2
A. Finisher Unit	6-1	B. Saddle Stitcher Unit	6-2
B. Saddle Stitcher Unit	6-1	C. Puncher Unit (option)	6-2
C. Puncher Unit (option)	6-1	III. PERIODICAL SERVICING	6-2
II. CONSUMABLES AND DURABLES	6-2		

CHAPTER 7 TROUBLESHOOTING

I. ADJUSTMENTS	7-1	A. Finisher Unit	7-10
A. Electrical System (finisher unit)	7-1	B. Saddle Stitcher Unit	7-18
B. Electrical System (saddle stitcher unit)	7-4	C. Puncher Unit (option)	7-26
C. Electrical System (puncher unit (option))	7-6	D. Light-Emitting Diodes (LED) and Check Pins by PCB	7-30
II. TEST MODE	7-7	IV. TROUBLESHOOTING	7-32
A. Finisher Unit	7-7	A. Finisher Unit	7-32
B. Saddle Stitcher Unit	7-8	B. Saddle Stitcher Unit	7-42
III. ARRANGEMENT OF ELECTRICAL PARTS	7-10	C. Puncher Unit (option)	7-50

APPENDIX

A. SIGNAL AND ABBREVIATIONS	A-1	E. SADDLE STITCHER UNIT PCB	A-17
B. FINISHER UNIT CIRCUIT DIAGRAM	A-2	F. PUNCHER UNIT (OPTION) CIRCUIT DIAGRAM	A-25
C. FINISHER CONTROLLER PCB	A-5	G. PUNCH DRIVER PCB	A-26
D. SADDLE STITCHER UNIT CIRCUIT DIAGRAM	A-15	H. SOLVENT AND OIL	A-28

CHAPTER 1

GENERAL DESCRIPTION

I. FEATURES.....	1-1		
II. SPECIFICATIONS	1-2		
A. Specifications	1-2		
B. Cross Section	1-9		
III. Using the Machine	1-12		
A. Removing Paper Jams from the Finisher Unit	1-12		
B. Supplying the Finisher Unit with Staples	1-13		
C. Removing Staple Jams from the Finisher Unit	1-15		
D. Removing Paper Jams from the Saddle Stitcher Unit (Saddle Finisher)	1-16		
E. Supplying the Saddle Stitcher Unit with Staples (Saddle Finisher)	1-18		
F. Removing Staple Jams from the Saddle Stitcher Unit (Saddle Finisher)	1-19		
G. Removing Paper Jams from the Puncher Unit (option) ...	1-21		
H. Removing Punched Scrap from the Puncher Unit (option)	1-22		
IV. MAINTENANCE BY THE USER.....	1-23		
A. Maintenance by the User	1-23		

I. FEATURES

1. Accommodates large quantities of sheets.

- Normally, the finisher holds a stack of sheets 147 mm in height in its two bins (small-size paper: equivalent to 1000 sheets)/74 mm in height (large-size paper: equivalent to 500 sheets)

2. Has high paper transportation performance.

- The finisher is capable of handling paper between 60 and 256 g/m².

3. Offers a job offset function.

- The finisher has a job offset function for sorting non-stapled stacks of copies.

4. Offers four types of auto stapling.

- The finisher offers a choice of four stapling modes (1-point stapling at rear, diagonal stapling at front, diagonal stapling at rear, 2-point stapling).

5. Uses a buffer roller.

- The use of a buffer roller enables the finisher to accept copies without interruption from the host machine even during stapling or offset operation.

6. Has a saddle stitch function (Saddle Finisher).

- The finisher can staple along the center of paper and fold it in two (up to 15 sheets).

7. Offers a punch function (option).

- The use of the puncher unit enables the finisher to punch sheets for binders before they are output. (The puncher unit is capable of handling papers between 64 and 256 g/m². It cannot handle special paper, postcards and transparencies.)

II. SPECIFICATIONS

A. Specifications

1. Finisher Unit

Item	Description		
Stacking method	Trays 1 and 2: by lifting tray		
Stacking orientation	Face up		
Stacking size	AB: A3, A4, A4-R, A5-R, B4, B5, B5-R Inch: LD, LG, LT, LT-R, ST-R, FOLIO, COMPUTER		
Basis weight	Plain paper : 60 to 105 g/m ² Special paper / Thick paper : 106 to 256 g/m ²		
Bins	Trays 1 and 2		
Modes	Non-sort: trays 1 and 2 Sort: trays 1 and 2 Staple: trays 1 and 2		
Stacking capacity	Non-staple-sort	Small-size (Note 1)	Tray 1: 147 mm/5.79 in. high (1000 sheets) (Note 4) Tray 2: 147 mm/5.79 in. high (1000 sheets) (Note 4)
		Large-size (Note 1)	Tray 1: 74 mm/2.91 in. high (500 sheets) Tray 2: 74 mm/2.91 in. high (500 sheets)
	Staple sort	Small-size (Note 1)	Tray 1: 110 mm high/50 sets (750 sheets) (Note 4) : 4.33 in. high/50 sets (750 sheets) (Note 4) Tray 2: 110 mm high/50 sets (750 sheets) (Note 4) : 4.33 in. high/50 sets (750 sheets) (Note 4)
		Large-size (Note 1)	Tray 1: 74 mm high/50 sets (500 sheets) : 2.91 in. high/50 sets (500 sheets) Tray 2: 74 mm high/50 sets (500 sheets) : 2.91 in. high/50 sets (500 sheets)
	Non-staple-sort	Small-size (Note 2)	Tray 1: 147 mm/5.79 in. high (850 sheets) (Note 4) Tray 2: 147 mm/5.79 in. high (850 sheets) (Note 4)
		Large-size (Note 2)	Tray 1: 74 mm/2.91 in. high (400 sheets) Tray 2: 74 mm/2.91 in. high (400 sheets)
	Staple sort	Small-size (Note 2)	Tray 1: 110 mm high/30 sets (600 sheets) (Note 4) : 4.33 in. high/30 sets (600 sheets) (Note 4) Tray 2: 110 mm high/30 sets (600 sheets) (Note 4) : 4.33 in. high/30 sets (600 sheets) (Note 4)
		Large-size (Note 2)	Tray 1: 74 mm high/30 sets (400 sheets) : 2.91 in. high/30 sets (400 sheets) Tray 2: 74 mm high/30 sets (400 sheets) : 2.91 in. high/30 sets (400 sheets)

Item	Description		
Stacking capacity	Non-staple-sort	Small-size (Note 3)	Tray 1: 147 mm/5.79 in. high (750 sheets) ^(Note 4) Tray 2: 147 mm/5.79 in. high (750 sheets) ^(Note 4)
		Large-size (Note 3)	Tray 1: 74 mm/2.91 in. high (350 sheets) Tray 2: 74 mm/2.91 in. high (350 sheets)
	Staple sort	Small-size (Note 3)	Tray 1: 110 mm high/30 sets (550 sheets) ^(Note 4) : 4.33 in. high/30 sets (550 sheets) ^(Note 4) Tray 2: 110 mm high/30 sets (550 sheets) ^(Note 4) : 4.33 in. high/30 sets (550 sheets) ^(Note 4)
		Large-size (Note 3)	Tray 1: 74 mm high/30 sets (350 sheets) : 2.91 in. high/30 sets (350 sheets) Tray 2: 74 mm high/30 sets (350 sheets) : 2.91 in. high/30 sets (350 sheets)
Size mixing	Size mixing: 74 mm or less (500 sheets) Stapling: 74 mm or less (500 sheets)		
Stacking mixing	Face up		

Notes:

1. Approximate when computed with reference to 80 g/m² paper. The stacking capacity is only reference. It is not guaranteed.
2. Approximate when computed with reference to 90 g/m² paper. The stacking capacity is only reference. It is not guaranteed.
3. Approximate when computed with reference to 105 g/m² paper. The stacking capacity is only reference. It is not guaranteed.
4. Alignment may not be correct if 750 or more small-size sheets are stacked.
5. The accuracy of the stack height is ± 7 mm/0.28 in.

Table 1-201

Item	Description		
Stapling	By rotating cam		
Stapling position	See Figure 1-201.		
Stapling capacity	Small-size	50 sheets	Equivalent of 64 to 80 g/m ² paper
	Large-size	30 sheets	
	Small-size	30 sheets	Equivalent of 81 to 90 g/m ² paper
	Large-size	15 sheets	
	Small-size	30 sheets	Equivalent of 91 to 105 g/m ² paper
	Large-size	15 sheets	
Staple supply	Special staple cartridge (5000 staples)		
Staples	Special (STAPLE-700)		
Staple detection	Provided		
Manual stapling	Not provided		
Stapling size	1-point diagonal stapling	Front	A3, B4, A4, A4-R, B5, LD LG, LT, LT-R, FOLIO, COMPUTER
		Rear	A3, B4, A4, B5, LD, LT, COMPUTER
	1-point	Rear	A4-R, LT-R, LG, FOLIO
	2-point	A3, B4, A4, B5, LD, LG, LT, A4-R, LT-R, COMPUTER, FOLIO	
Paper detection	Provided		
Control panel	Not provided		
Display	Not provided		
Dimensions	599 (675) × 615 × 1020 mm (W (with Puncher Unit attached) x D x H; including saddle stitcher unit)		
Weight	Finisher :	36 kg	
	Saddle finisher :	56 kg	
	Puncher unit (option) :	6 kg	
Power supply	From host machine (24 VDC)		
Maximum power consumption	170 W or less		

Table 1-202

Reference:

The term “small-size” stands for A4, A5-R, B5, LT, ST-R, while the term “large-size” stands for A3, B4, B5-R, A4-R, LT-R, LD, LG, FOLIO, COMPUTER.

Stapling Positions (finisher unit)

Unit: mm, Allowance: ± 4 mm

① 1-point stapling
(diagonal, front)

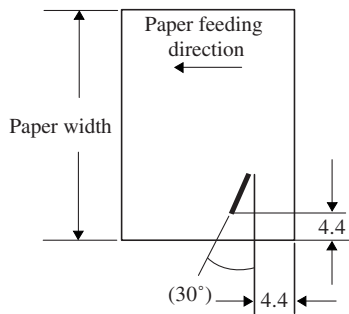

② 1-point stapling (rear)

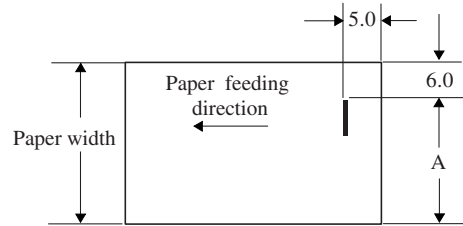

Size	A
A4-R, FOLIO	204.0
LT-R, LG	210.0

③ 1-point stapling
(diagonal, rear)

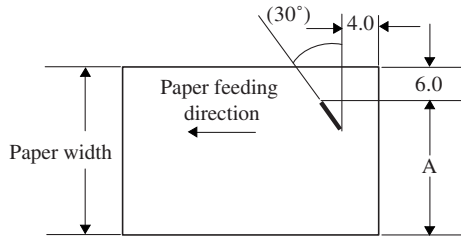

Size	A
A3, A4	291.0
B4, B5	251.0
LD, LT	273.5

④ 2-point stapling

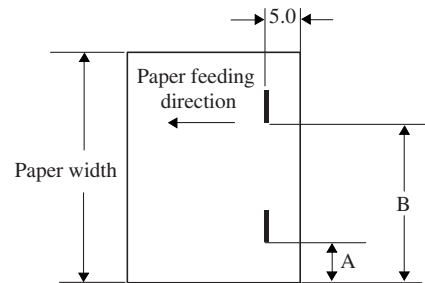

Size	A	B
A3, A4	83.0	203.0
B4, B5, COMPUTER	63.0	183.0
LD, LT	74.0	194.0
A4-R, FOLIO	62.5	138.5
LT-R, LG	62.5	144.5

Figure 1-201

2. Saddle Stitcher Unit

Item	Description	
Stapling method	Center binding (double folding)	
Folding position	See Figure 1-202.	
Paper size	A3, B4, A4-R, LD, LT-R	
Capacity	Without binding: 1 sheet (including single cover page) With binding: 15 sheets: 64 g/m ² to 80 g/m ² 8 sheets: 81 g/m ² to 105 g/m ²	
Basis weight (MJ-1020)	64 to 80 g/m ² (cover page up to 256 g/m ²) ^(Note 1)	
Stacking capacity	10 sets (stack of 11 to 15 sheets), 20 sets (stack of 6 to 10 sheets), 25 sets (stack of 5 sheets or less)	64 g/m ² to 80 g/m ²
	15 sets (stack of 6 to 10 sheets), 20 sets (stack of 5 sheets or less)	81 g/m ² to 105 g/m ²
Stapling	Stapling position	2 points (center distribution; fixed interval)
	Staple accommodation	2000 staples
	Staple supply	Special cartridge
	Staples	Special staples (STAPLE-600)
	Staple detection	Provided
	Manual stapling	Not provided
Folding	Folding method	Roller contact
	Folding mode	Double folding
	Folding position	Paper center
	Position adjustment	Provided
Power supply	From finisher unit (24 VDC, 5 VDC)	
Power consumption	160 W or less	

Note1: Special paper, postcards, transparencies, reproducibles, label paper and hole-punched paper cannot be handled.

Table 1-203

Staple and Folding Position (saddle finisher unit)

Unit: mm, Allowance: $\pm 2.5\text{mm}$

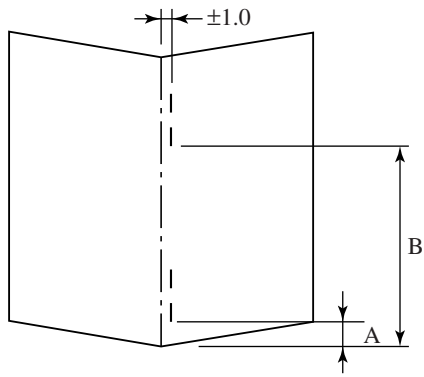

Size	A	B
A3	83.0	203.0
B4	63.0	183.0
A4-R	39.5	159.5
LD	74.0	194.0
LT-R	42.0	162.0

Figure 1-202

3. Puncher Unit (Option)

Item	Description	
Punching method	Sequential punching	
Paper size	See the figures below	
Basis weight	64 to 256 g/m ² (Note 1)	
Punched hole diameter	See the figures below	
Punched scrap capacity	2 holes: 5,000 sheets 2 or 3 holes: 3,000 sheets 4 holes: 5,000 sheets	(80 g/m ² or equivalent)
Power supply	From the finisher unit (24 VDC, 5 VDC)	
Power consumption	120 W or less	

Note1: Transparencies, reproducibles and such as special paper cannot be handled.

Hole position (Paper trailing edge) Unit:mm

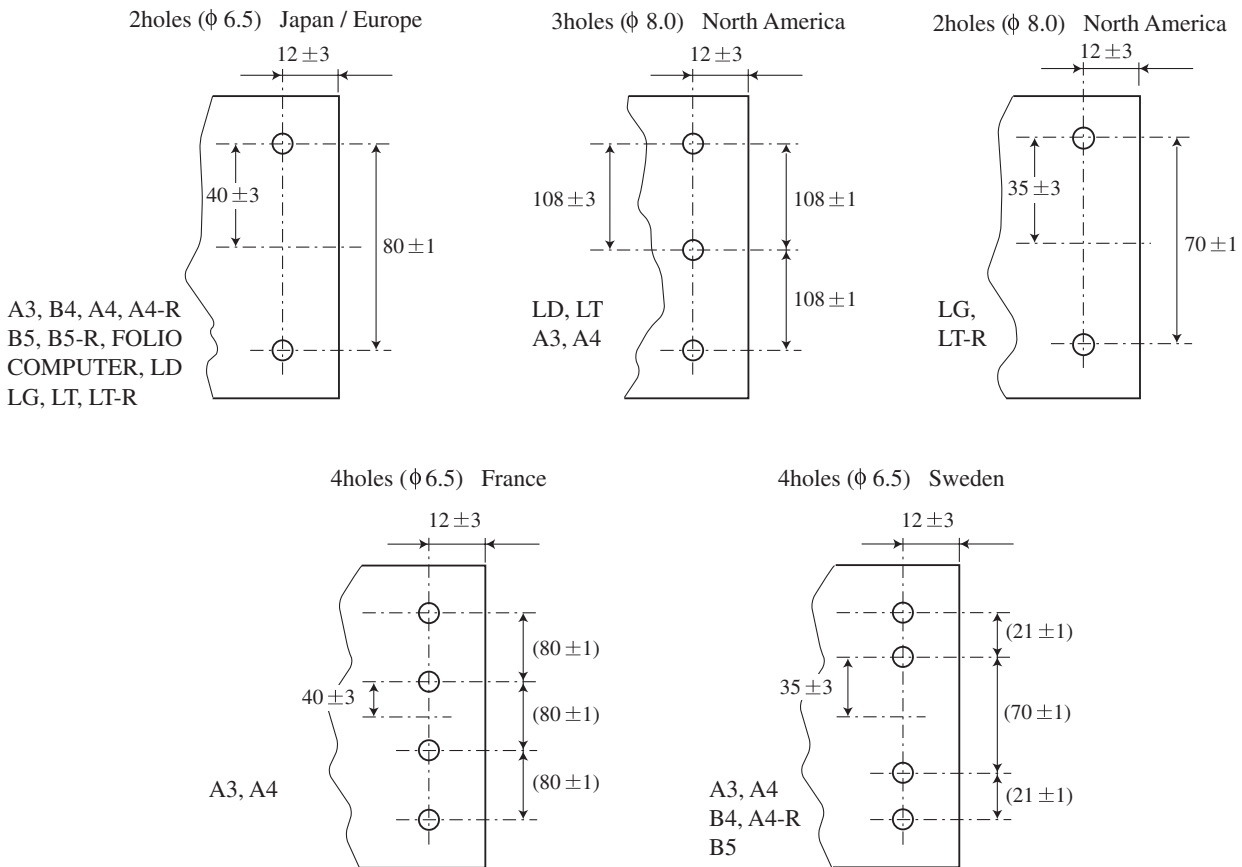
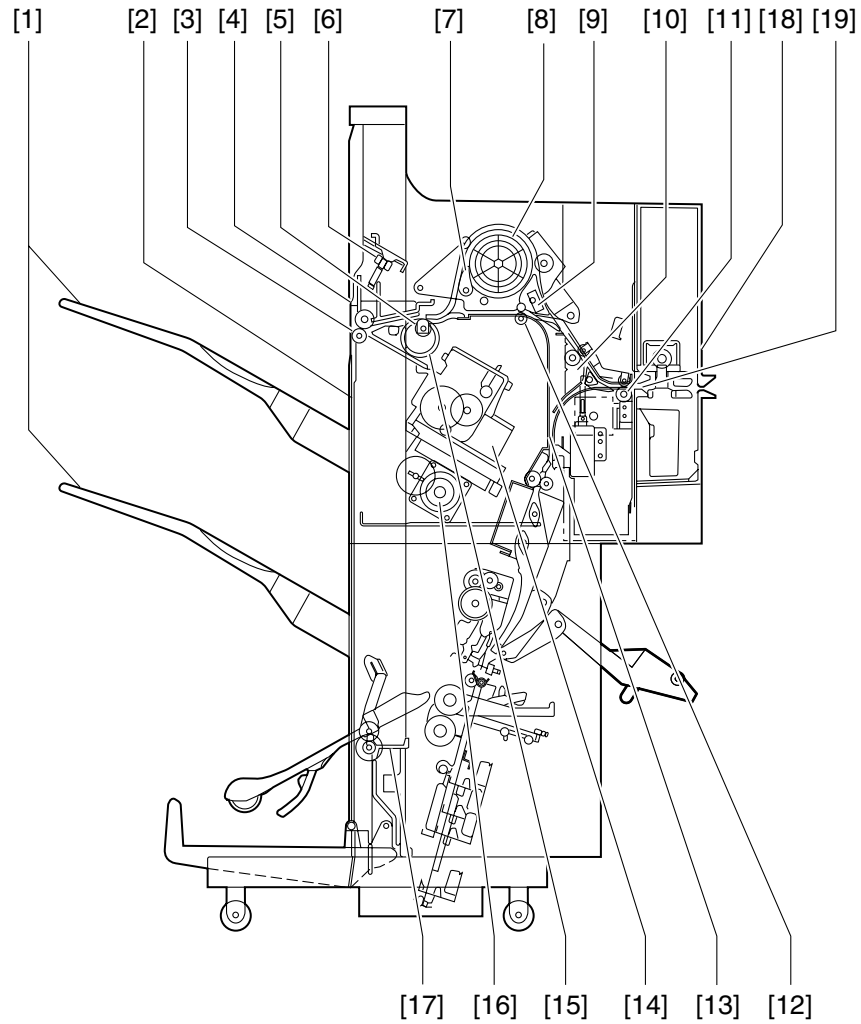

Figure 1-203

Specifications are subject to change without notice.

B. Cross Section

1. Finisher Unit



- | | |
|------------------------------|--|
| [1] Tray 1/2 | [11] Inlet feed roller |
| [2] Shutter | [12] Feed roller 1 |
| [3] Delivery roller | [13] Vertical path |
| [4] Swing guide | [14] Stapler |
| [5] Feed roller 2 | [15] Knurled belt |
| [6] Height sensor | [16] Tray lift motor |
| [7] Wrap flapper | [17] Saddle stitcher unit
(Saddle Finisher) |
| [8] Buffer roller | [18] Latch unit |
| [9] Buffer inlet flapper | [19] Inlet feed section |
| [10] Saddle stitcher flapper | |

Figure 1-204

2. Saddle Stitcher Unit

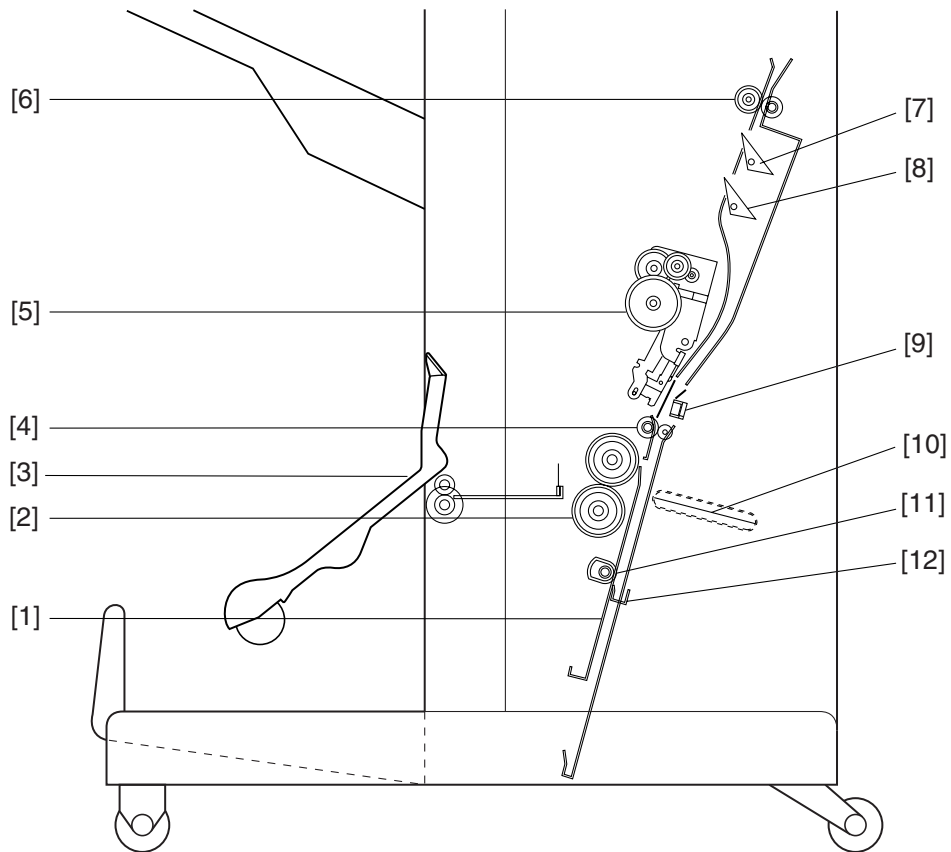

- | | |
|---------------------------|---------------------------------|
| [1] Guide plate | [7] No. 1 flapper |
| [2] Folding roller | [8] No. 2 flapper |
| [3] Delivery guide plate | [9] Sticher plate (front, rear) |
| [4] Holding roller | [10] Butting plate |
| [5] Sticher (front, rear) | [11] Crescent roller |
| [6] Inlet roller | [12] Paper positioning plate |

Figure 1-205

3. Puncher Unit (option)

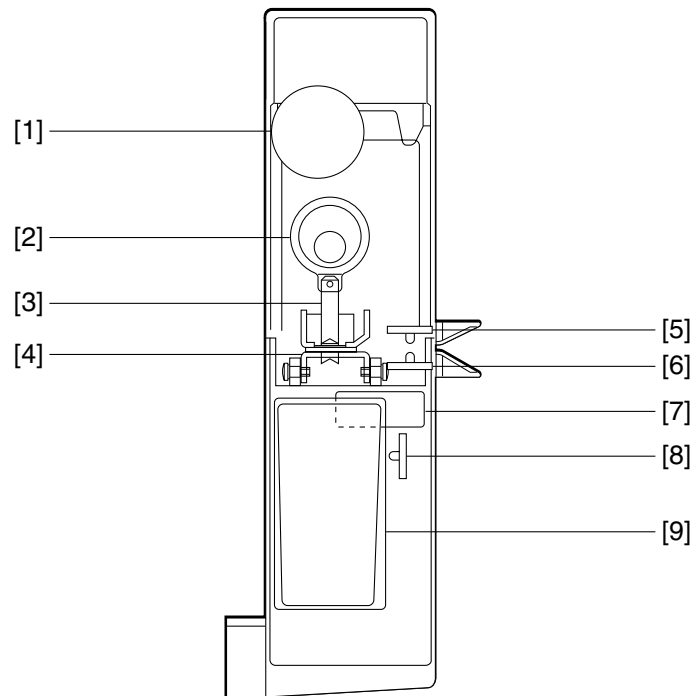

- | | |
|--------------------------------|-----------------------------------|
| [1] Punch motor | [6] LED PCB |
| [2] Cam | [7] Horizontal registration motor |
| [3] Hole puncher (Punch blade) | [8] Scrap-full detector PCB unit |
| [4] Die | [9] Punched scrap container |
| [5] Photosensor PCB | |

Figure 1-206

III. USING THE MACHINE

A. Removing Paper Jams from the Finisher Unit

If the host machine indicates the finisher paper jam message, perform the following to remove the jam.

- 1) Holding the latch lever down as shown, move it to detach it from the host machine.

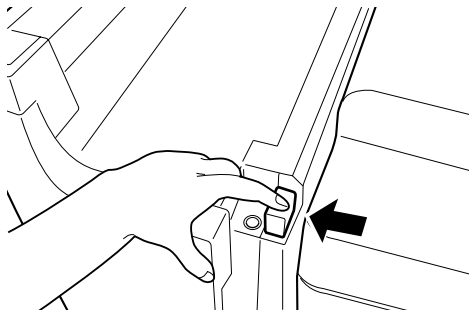

Figure 1-301

- 2) Remove any jam visible from the outside.

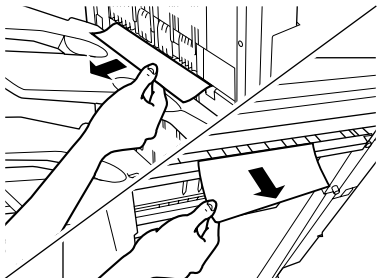

Figure 1-302

- 3) Open the upper cover and check the inside of the finisher.

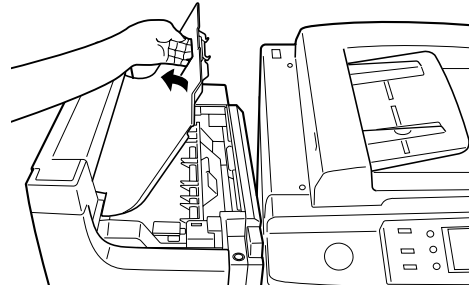

Figure 1-303

- 4) Lift the buffer roller cover and remove the jam.

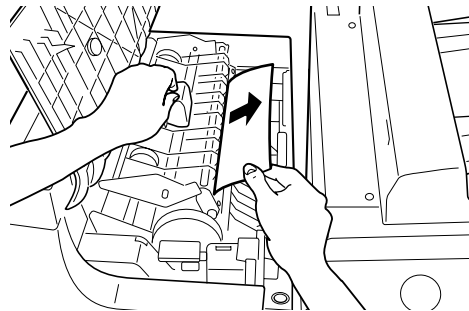

Figure 1-304

- 5) Lift the buffer roller and remove the jam.

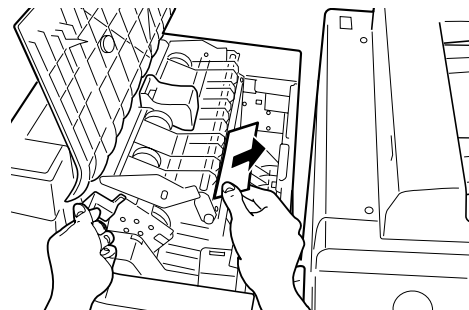

Figure 1-305

- 6) Return the buffer roller and the buffer roller cover to their original positions, and close the upper cover.

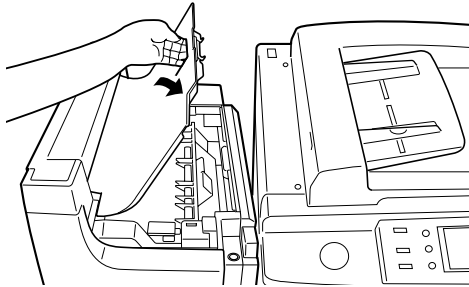

Figure 1-306

- 7) Connect the finisher to the host machine.

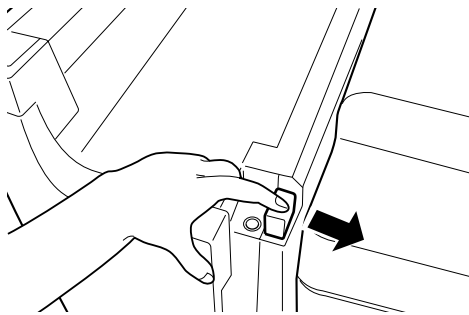

Figure 1-307

- 8) Operate as instructed on the display.

B. Supplying the Finisher Unit with Staples

If the copier indicates the finisher unit staple supply message, perform the following to supply it with staples.

- 1) Open the front door.

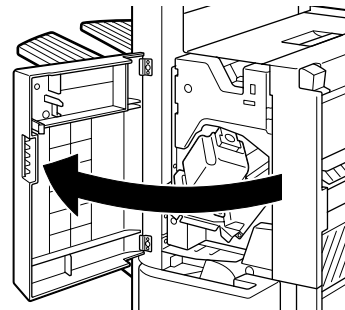

Figure 1-308

- 2) Turn the blue knob counterclockwise.

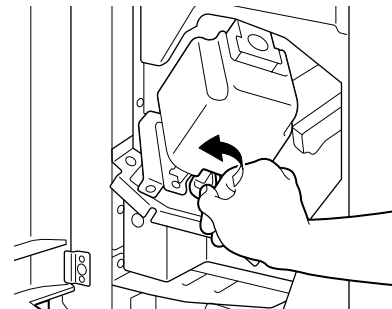

Figure 1-309

- 3) Draw out the staple unit, and pull the staple cartridge up-ward.

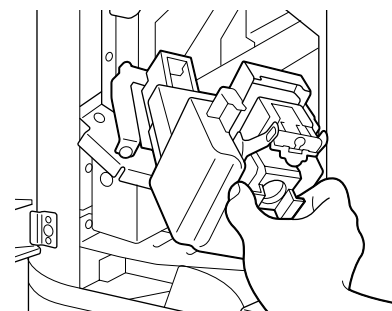

Figure 1-310

- 4) Push the blue knob and pull out the empty staple case.

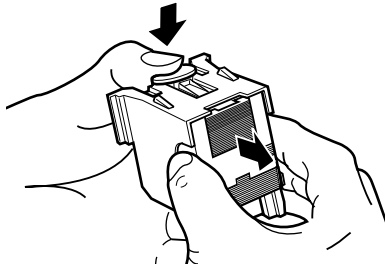

Figure 1-311

- 6) Pull the length of tape (used to hold the staples in place) straight out.

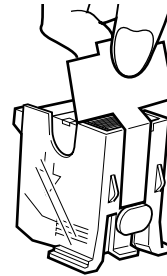

Figure 1-313

- 5) Set a new staple case.

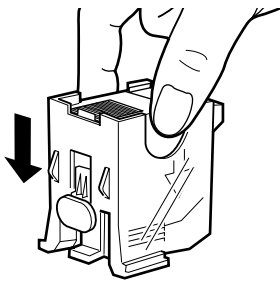

Figure 1-312

- 7) Set the staple cartridge.

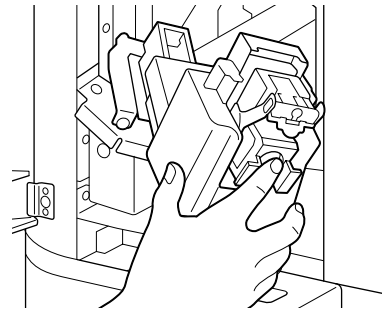

Figure 1-314

Reference:

You may set no more than one staple cartridge at a time.

Make sure that the new cartridge is one specifically designed for the finisher unit.

* Do not tear off the seal which fixes the staples before setting them in the cartridge.

- 8) Push in the stapler unit completely until it stops and turn the blue knob clockwise to lock it and close the front door.

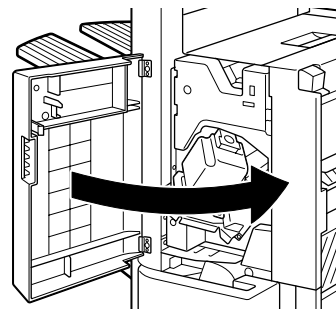

Figure 1-315

C. Removing Staple Jams from the Finisher Unit

If the copier indicates the finisher unit staple jam message, perform the following to remove the jam.

- 1) Remove the stack waiting to be stapled from the delivery tray.

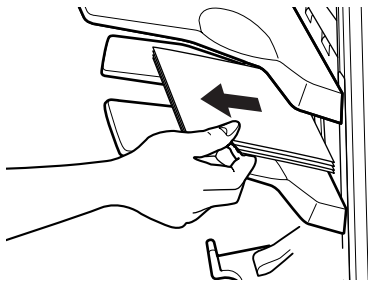

Figure 1-316

- 2) Open the front door.

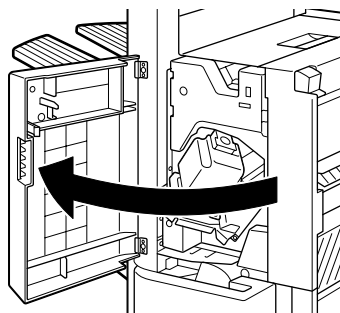

Figure 1-317

- 3) Turn the blue knob counterclockwise.

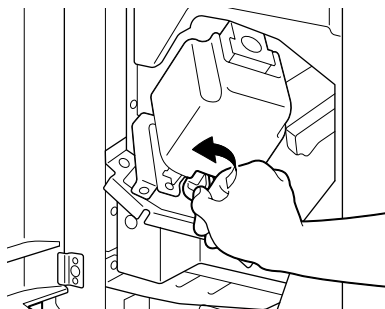

Figure 1-318

- 4) Draw out the stapler unit and then lift it up.

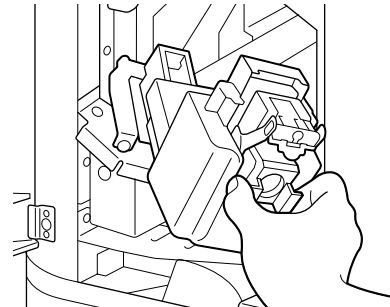

Figure 1-319

- 5) Remove the lock of the stopper and open the staple cover.
* Lift up the metal knob softly to open the staple cover.

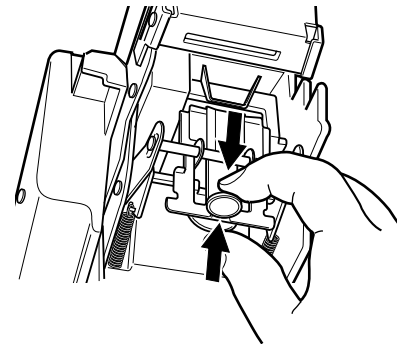

Figure 1-320

- 6) Remove the jammed staples.

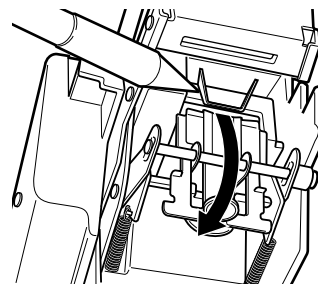

Figure 1-321

- 7) Push down the metallic knob and close the staple cover.
- 8) Return the stapler unit to its original position, and turn the blue knob clockwise to lock it.

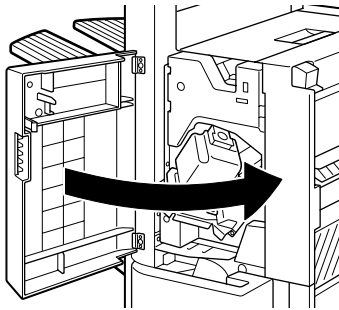

Figure 1-322

- 9) Close the front door.

Reference:

When the door has been closed, the stapler unit will automatically execute idle punching several times to advance the staples.

D. Removing Paper Jams from the Saddle Stitcher Unit (Saddle Finisher)

If the host machine indicates the saddle stitcher unit paper jam message, perform the following to remove the jam.

- 1) Holding the latch lever down unit as shown, move it to detach it from the host machine.

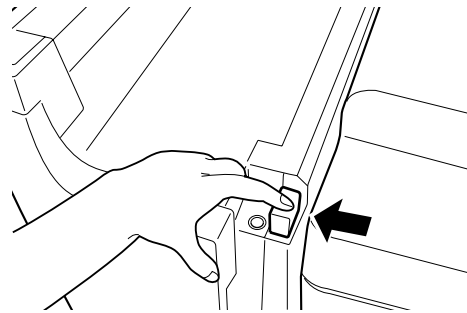

Figure 1-323

- 2) Open the front lower door.

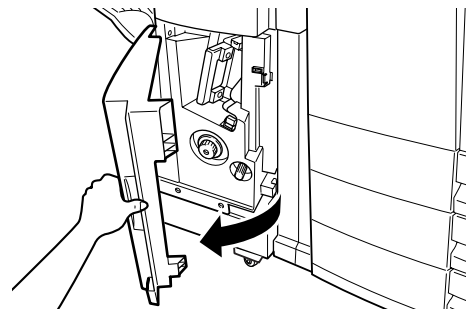

Figure 1-324

- 3) Turn the knob clockwise.

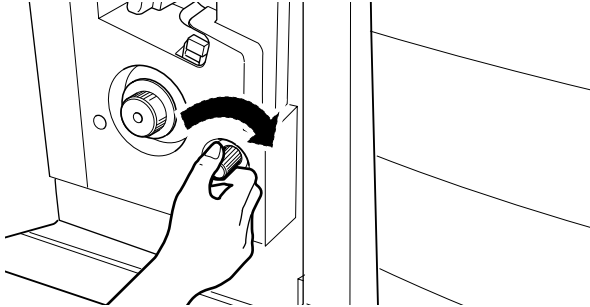

Figure 1-325

- 6) Open the inlet cover and remove the jam.

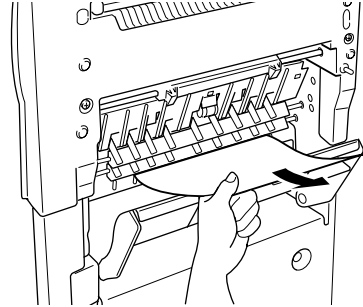

Figure 1-328

- 4) Turn the knob counterclockwise while pushing it in.

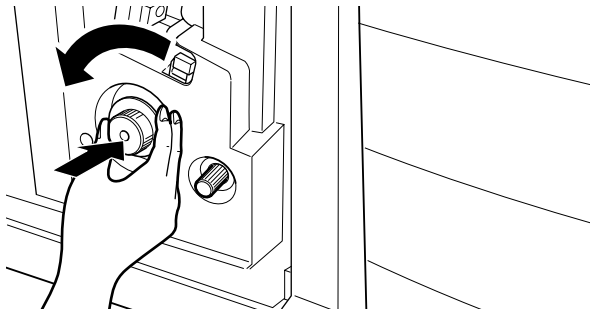

Figure 1-326

- 7) Close the front lower door.

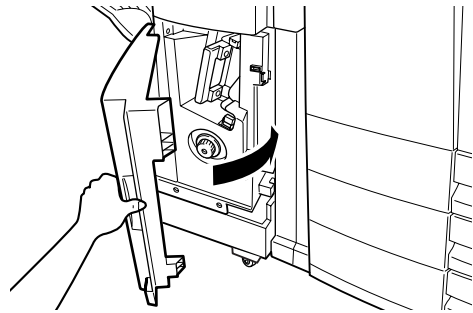

Figure 1-329

- 5) Remove the jam.

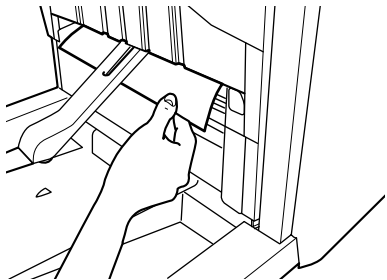

Figure 1-327

- 8) Connect the saddle finisher to the host machine.

- 9) Operate as instructed on the display.

E. Supplying the Saddle Stitcher Unit with Staples (Saddle Finisher)

If the host machine indicates the saddle stitcher unit staple supply message, perform the following to supply it with staples.

- 1) Open the front lower door.

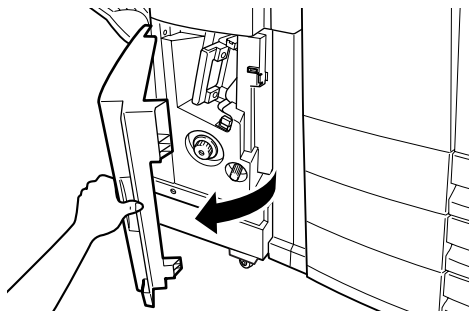

Figure 1-330

- 2) Slide out the stitcher unit.

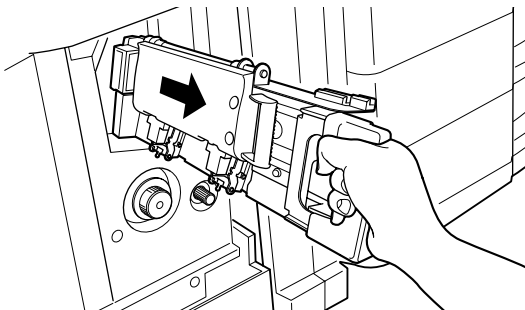

Figure 1-331

- 3) Pull the stitcher unit to the front once and then shift it up.

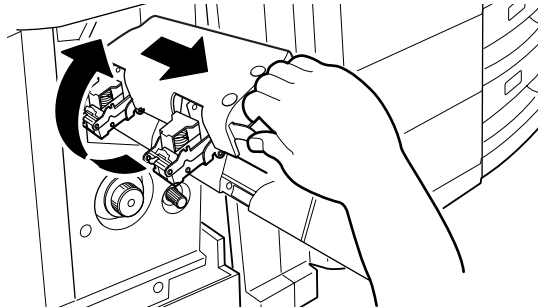

Figure 1-332

- 4) Hold the empty cartridge on its sides and remove it.

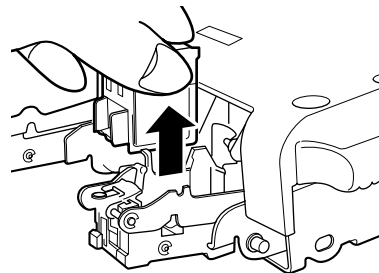

Figure 1-333

- 5) Set a new cartridge.

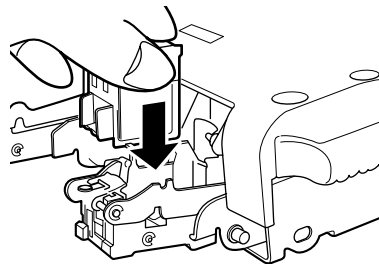

Figure 1-334

Reference

You must always replace both cartridges at the same time.

- 6) Pull the stitcher to the front once and then return it to its original position.

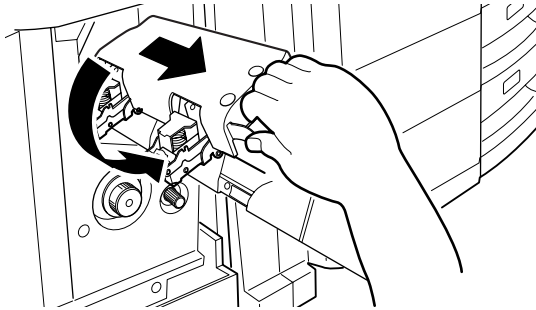

Figure 1-335

- 7) Push in the stitcher unit and close the front door.

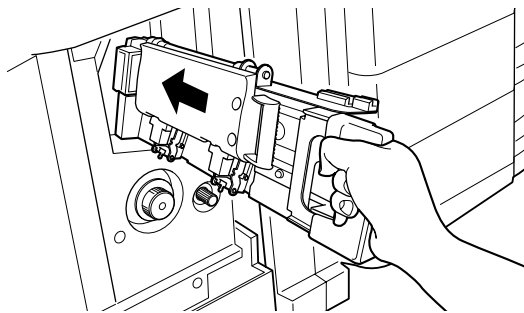

Figure 1-336

F. Removing Staple Jams from the Saddle Stitcher Unit (Saddle Finisher)

If the host machine indicates the saddle stitcher unit staple jam message, perform the following to remove the jam.

- 1) Open the front lower door.

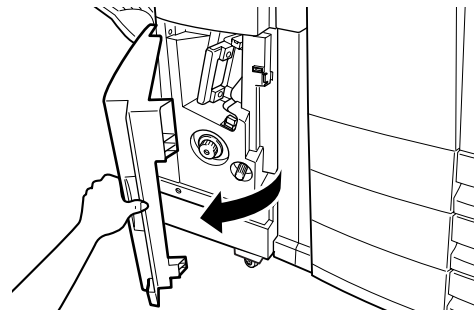

Figure 1-337

- 2) Slide out the stitcher unit.

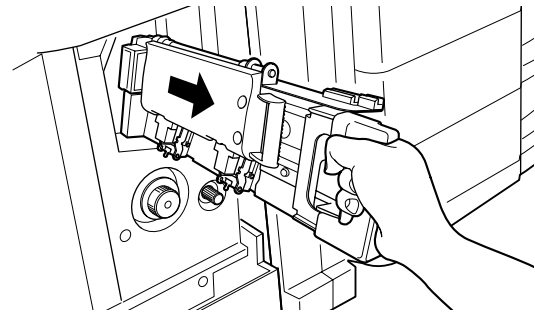

Figure 1-338

- 3) Pull the stapler of the stitcher unit to the front once and then shift it up.

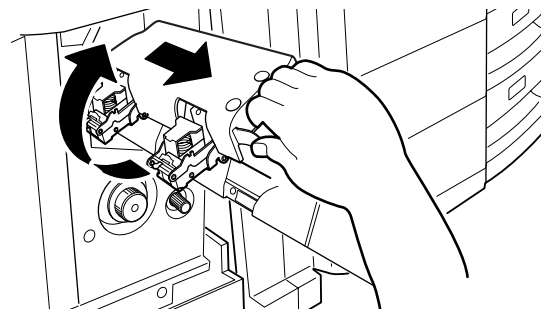

Figure 1-339

- 4) Hold the cartridge on its sides and remove it.

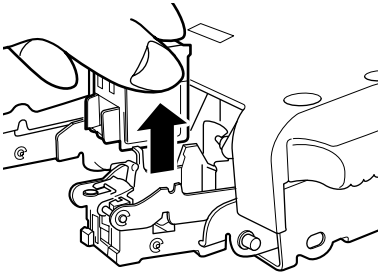

Figure 1-340

- 5) Push down on the area identified as A and pull up the tab identified as B.

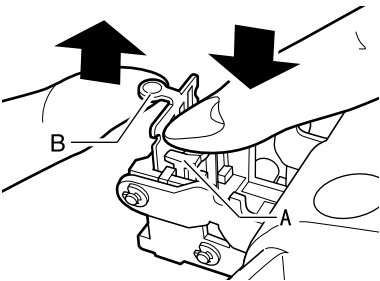

Figure 1-341

- 6) Remove the staple jam and return the tab B to its original position.

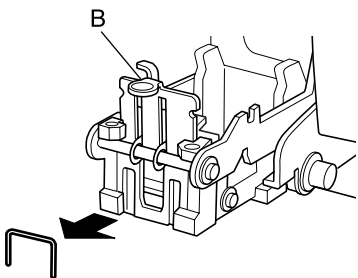

Figure 1-342

- 7) Return the cartridge to its original position.

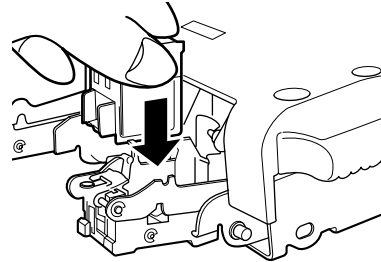

Figure 1-343

- 8) Pull the stitcher of the stitcher unit to the front once, and then return it to its original position.

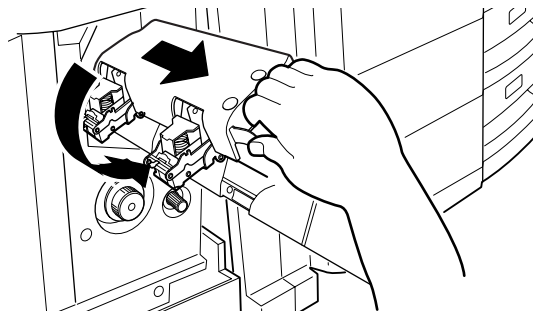

Figure 1-344

- 9) Push the stitcher unit back to its original position, and close the front lower door.

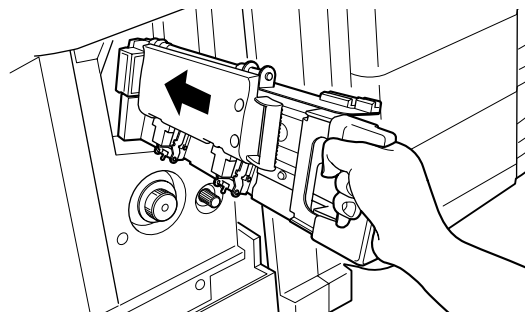

Figure 1-345

Reference

Whenever you have removed a staple jam, be sure to execute staple edging.

G. Removing Paper Jams from the Puncher Unit (option)

If the display indicates a paper jam on the puncher unit, perform the following to remove the jam:

- 1) Open the front door of the puncher unit.

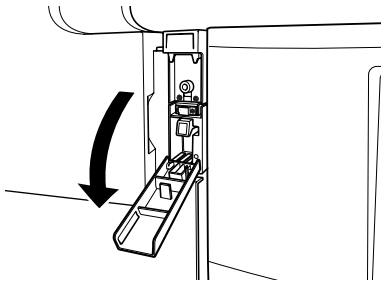

Figure 1-346

- 2) Align the triangle mark on the knob within the range marked by .

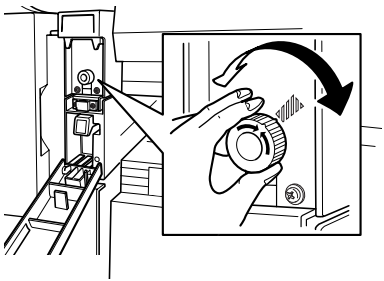

Figure 1-347

- 3) Close the front door of the puncher unit.

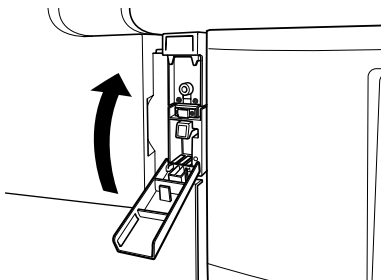

Figure 1-348

- 4) Open the upper cover.

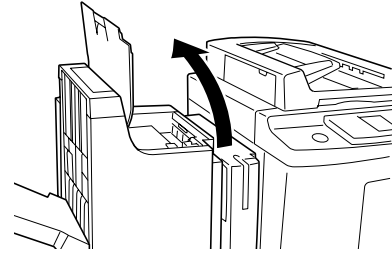

Figure 1-349

- 5) Remove the jam.

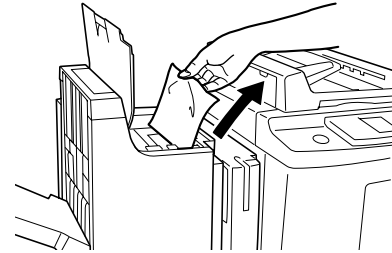

Figure 1-350

- 6) Close the upper cover.

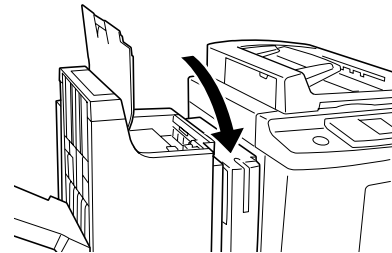

Figure 1-351

- 7) Operate as instructed on the display.

H. Removing Punched Scrap from the Puncher Unit (option)

If the display indicates a punched scrap full state on the puncher unit, perform the following to remove the punched scrap:

- 1) Open the front door of the puncher unit.

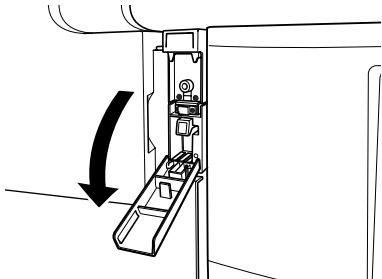

Figure 1-352

- 2) Slide out the punched scrap container.

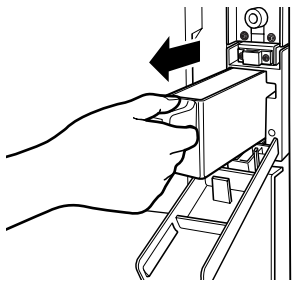

Figure 1-353

- 3) Discard the punched scrap.

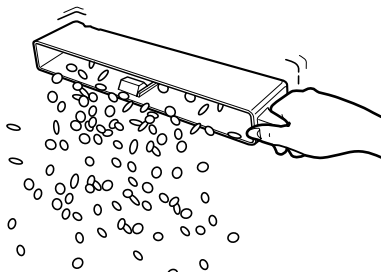

Figure 1-354

- 4) Return the punched scrap container to its original position.

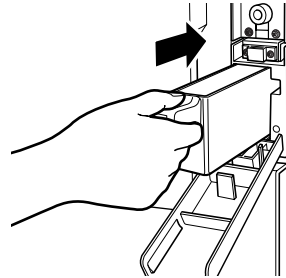

Figure 1-355

- 5) Close the front door of the puncher unit.

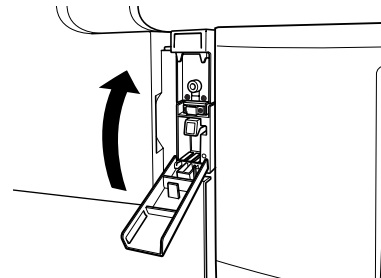

Figure 1-356

IV. MAINTENANCE BY THE USER

A. Maintenance by the User

No.	Item	Timing
1	Replacing the staple cartridge (finisher unit)	When the appropriate indication is made on the host machine's display.
2	Replacing the staple cartridge (saddle stitcher unit)	

Note:

The finisher unit and the saddle stitcher unit use different cartridge types. Be sure that the appropriate type is used for each.

Table 1-401

CHAPTER 2

FINISHER UNIT BASIC OPERATION

1. This chapter discusses the purpose and role of each of the finisher's functions, and the principles of operation used for the finisher mechanical and electrical systems. It also explains the timing at which these systems are operated. The  symbol in drawings indicates transmission of mechanical drive, and signals marked by \longrightarrow together with the signal name indicates the flow of electrical signals.
2. In descriptions of digital circuits on the finisher, "1" indicates a high signal voltage level, while "0" indicates a low signal voltage level. Voltage values differ according to the circuit.

A microprocessor is used on the finisher. A description of the microprocessor operation is omitted in this chapter as it is practically impossible to check the internal operation of the microprocessor.

Descriptions in this chapter also assume that PCBs will not be repaired at user sites. For this reason, descriptions of circuits on PCBs are limited to block diagrams. Two types of block diagrams are provided for separate functions: diagrams indicating details from sensors up to input sections of major PCBs, and diagrams indicating details from the output sections of major PCBs up the loads.

I. BASIC OPERATION	2-1	D. Job Offset	2-21
A. Outline	2-1	E. Stapling Operation	2-24
B. Outline of Electrical Circuitry	2-2	F. Stapler Unit	2-32
C. Inputs to and Outputs from the Finisher Controller PCB	2-4	G. Tray Operation	2-38
II. FEED/DRIVE SYSTEM	2-10	H. Detecting the Height of Stack on the Tray	2-40
A. Outline	2-10	I. Shutter Operation	2-42
B. Type of Delivery Paths	2-15	J. Buffer Path Operation	2-46
C. Feeding and Delivering	2-18	K. Detecting Jams	2-51
		III. POWER SUPPLY SYSTEM	2-56

I. BASIC OPERATION

A. Outline

The finisher is designed to deliver copies arriving from its host machine, and its modes of delivery include simple stacking, job offset^(Note), and stapling.

All operations involved in these modes are controlled by the finisher controller PCB, according to the appropriate commands from the host machine.

In the case of the Saddle Finisher, copies from the host machine may be routed to the saddle stitcher unit.

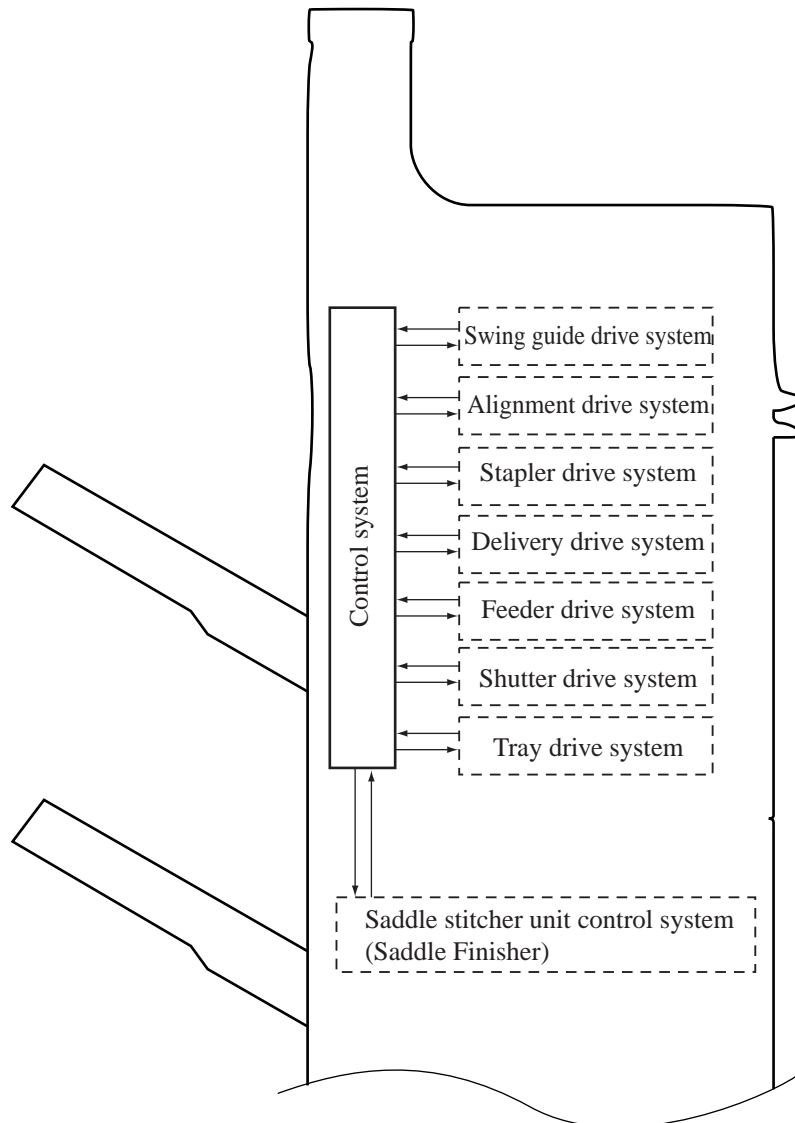

Figure 2-101

Note:

The term job offset refers to shifting each sorting job, separating a single stack into several stacks.

B. Outline of Electrical Circuitry

The finisher's sequence of operation is controlled by the finisher controller PCB. The finisher controller PCB is a 16-bit microprocessor (CPU), and is used for communication with the host machine (serial) in addition to controlling the finisher's sequence of operations.

The finisher controller PCB responds to the various commands coming from the host machine through a serial communications line to drive solenoids, motors, and other loads. In addition, it communicates the finisher's various states (information on sensors and switches) to the host machine through a serial communications circuit.

In the case of the Saddle Finisher, the finisher controller PCB not only communicates with the saddle stitcher controller PCB but also imparts the saddle stitcher unit's various states (information on sensors and switches) to the host machine.

The ICs used on the finisher controller PCB are designed for the following:

- Q1 (CPU)
Controls sequence of operations.
- Q2 (EEP-ROM)
Backs up adjustment values.
- Q7
Contains sequence programs.
- Q8/Q89 (RAM)
Backs up initial setting data.
- Q4 (communications IC)
Communicates with the host machine and the saddle stitcher unit.
- Q14 (regulator IC)
Generates 5V.

Figure 2-102 shows the flow of signals between the finisher and the options controller.

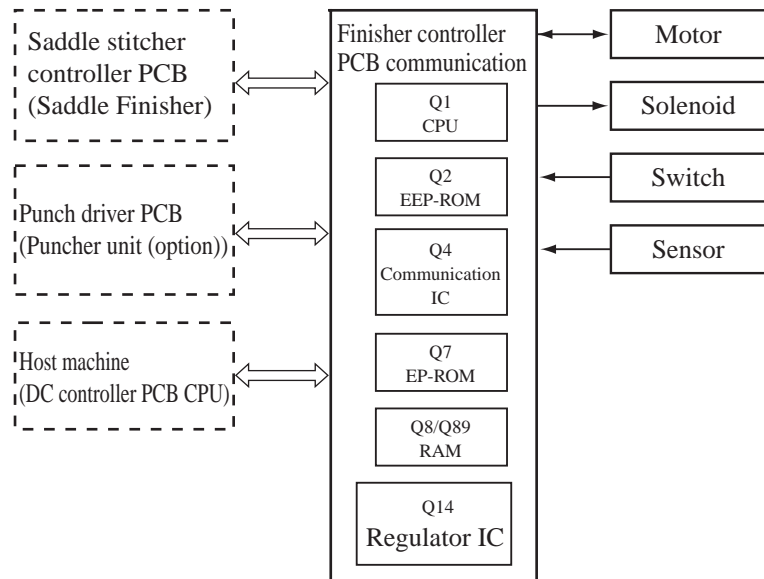

Figure 2-102

C. Inputs to and Outputs from the Finisher Controller PCB

1. Inputs to the Finisher Controller PCB

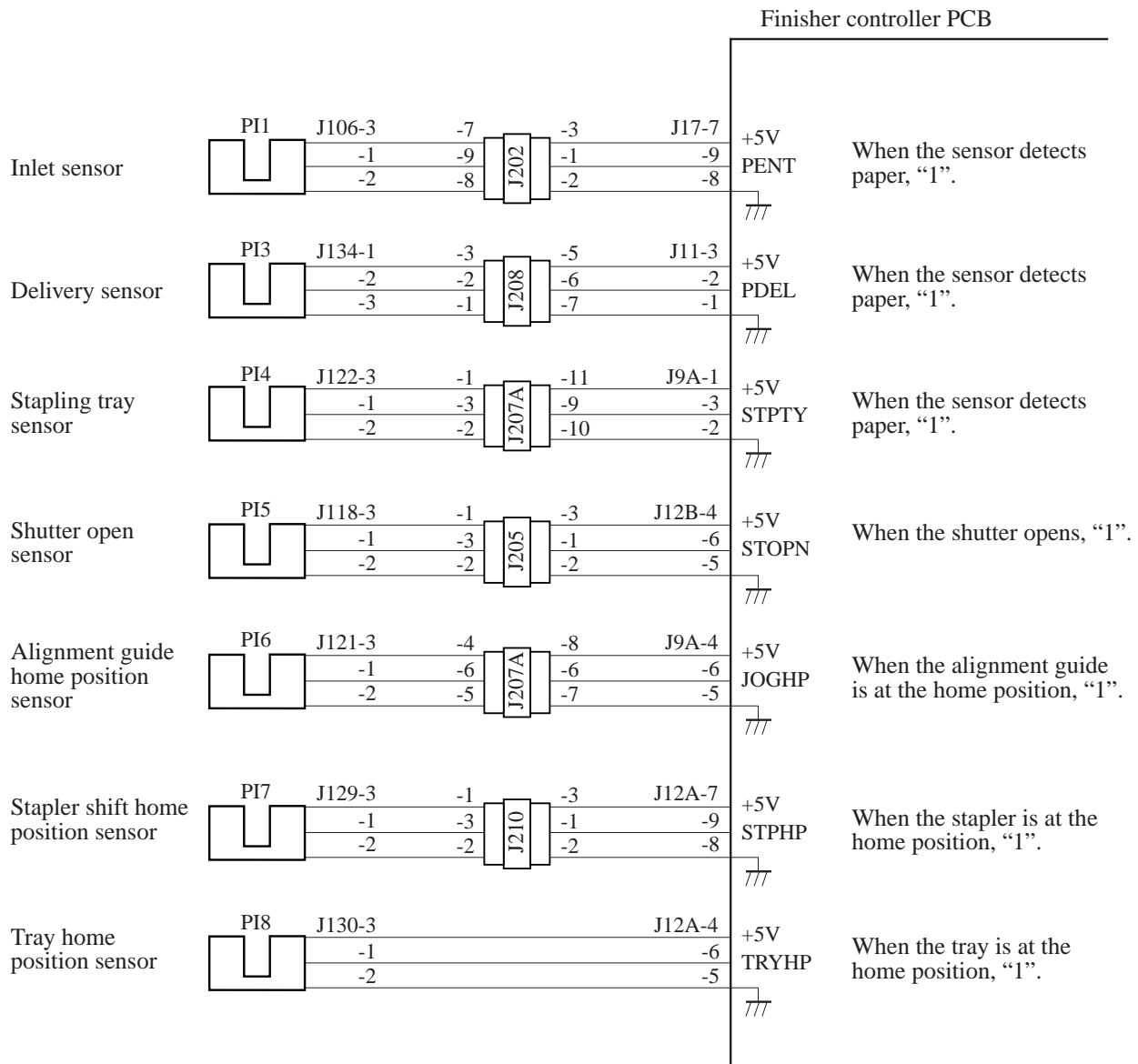

Figure 2-103

2. Inputs to the Finisher Controller PCB

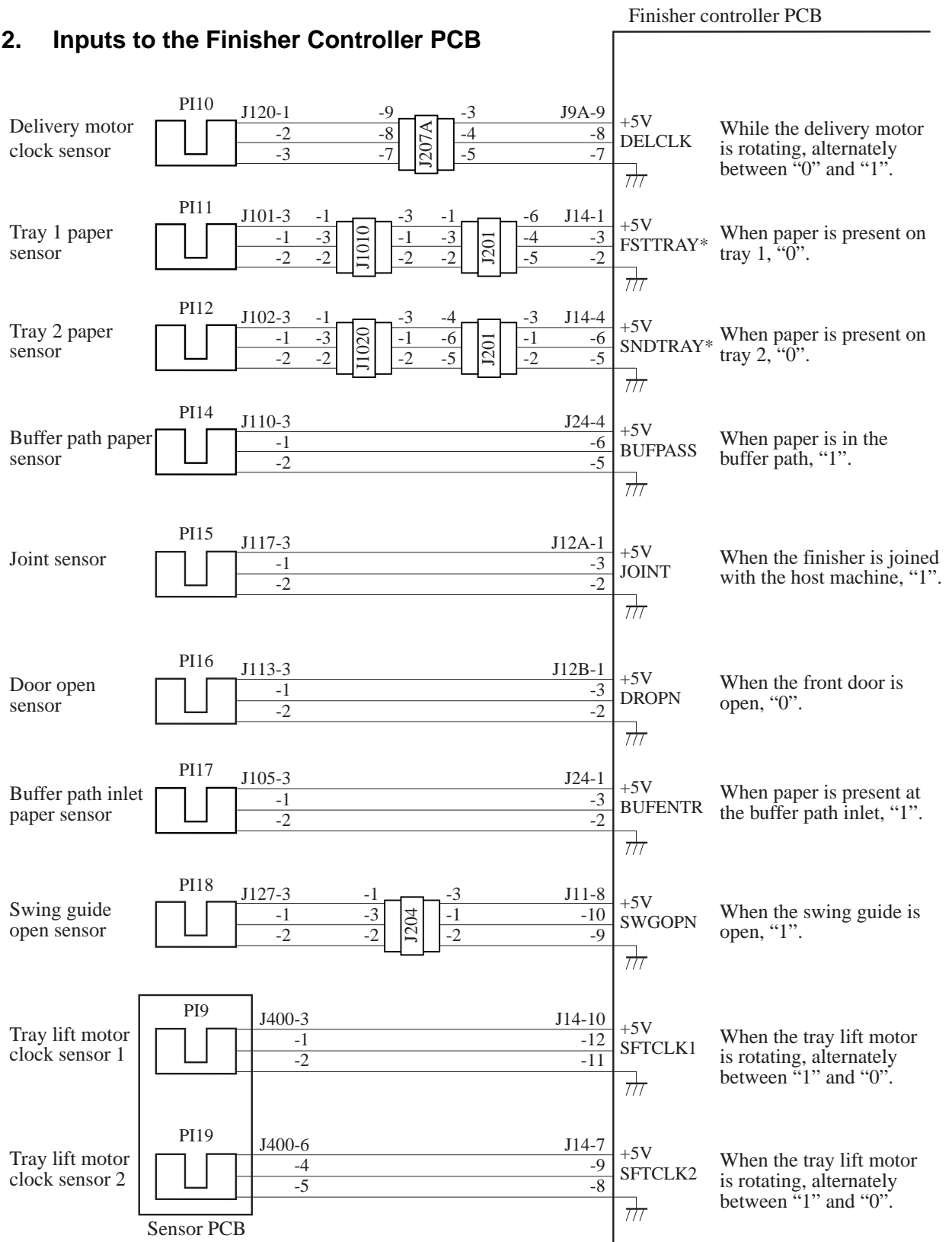

Figure 2-104

3. Inputs to the Finisher Controller PCB

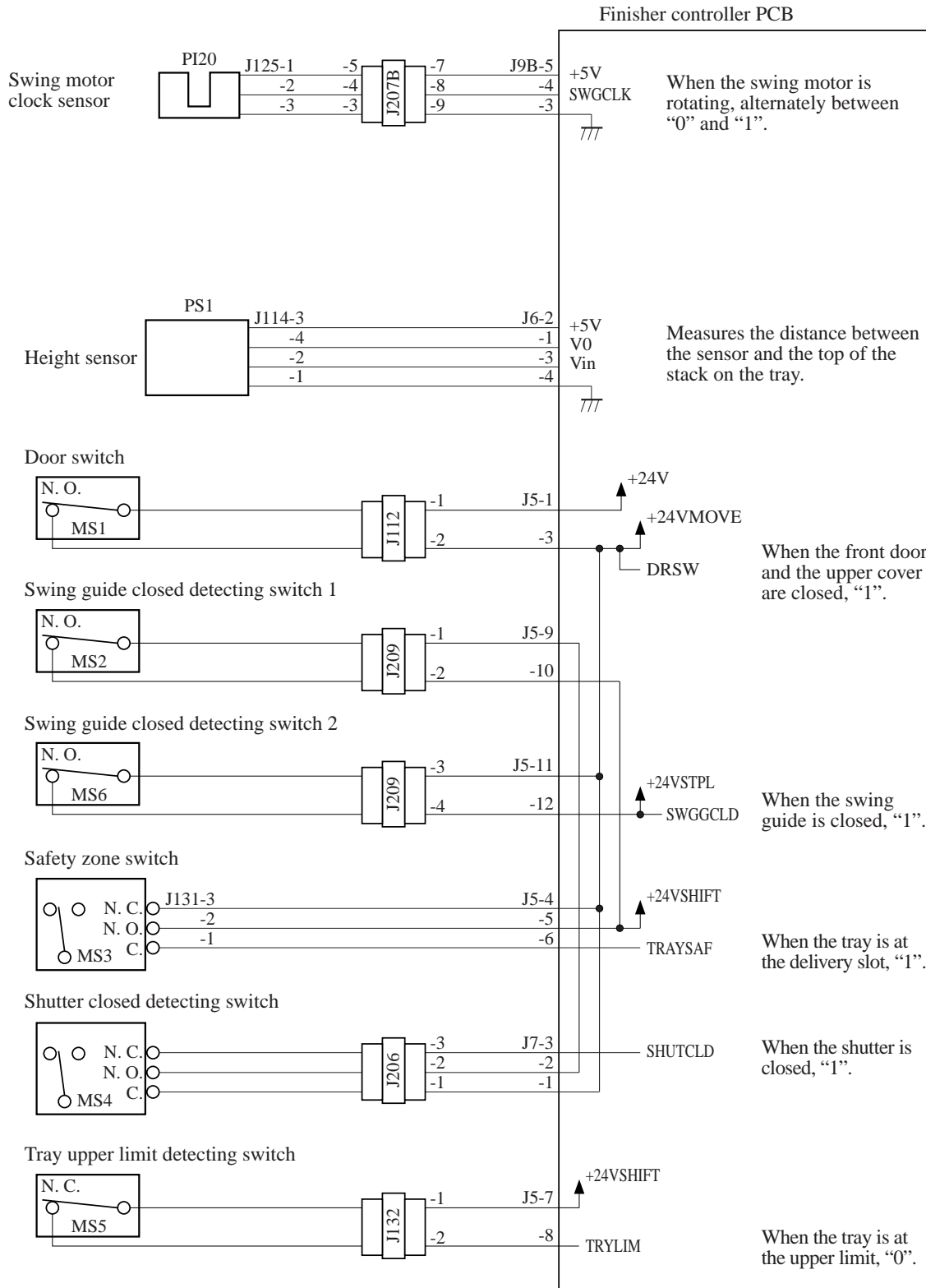

Figure 2-105

4. Inputs to and Outputs from the Finisher Controller PCB

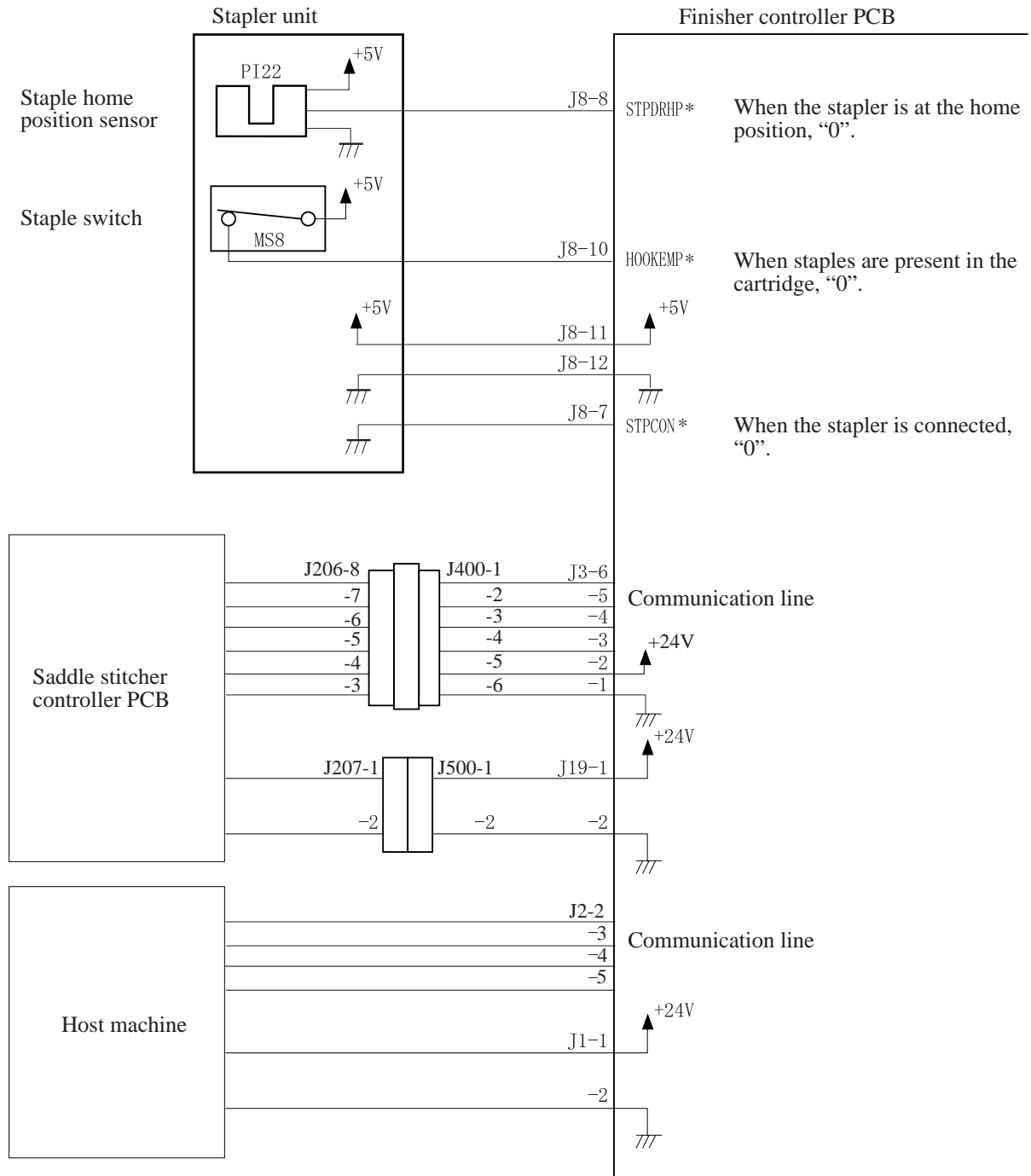

Figure 2-106

5. Outputs from the Finisher Controller PCB

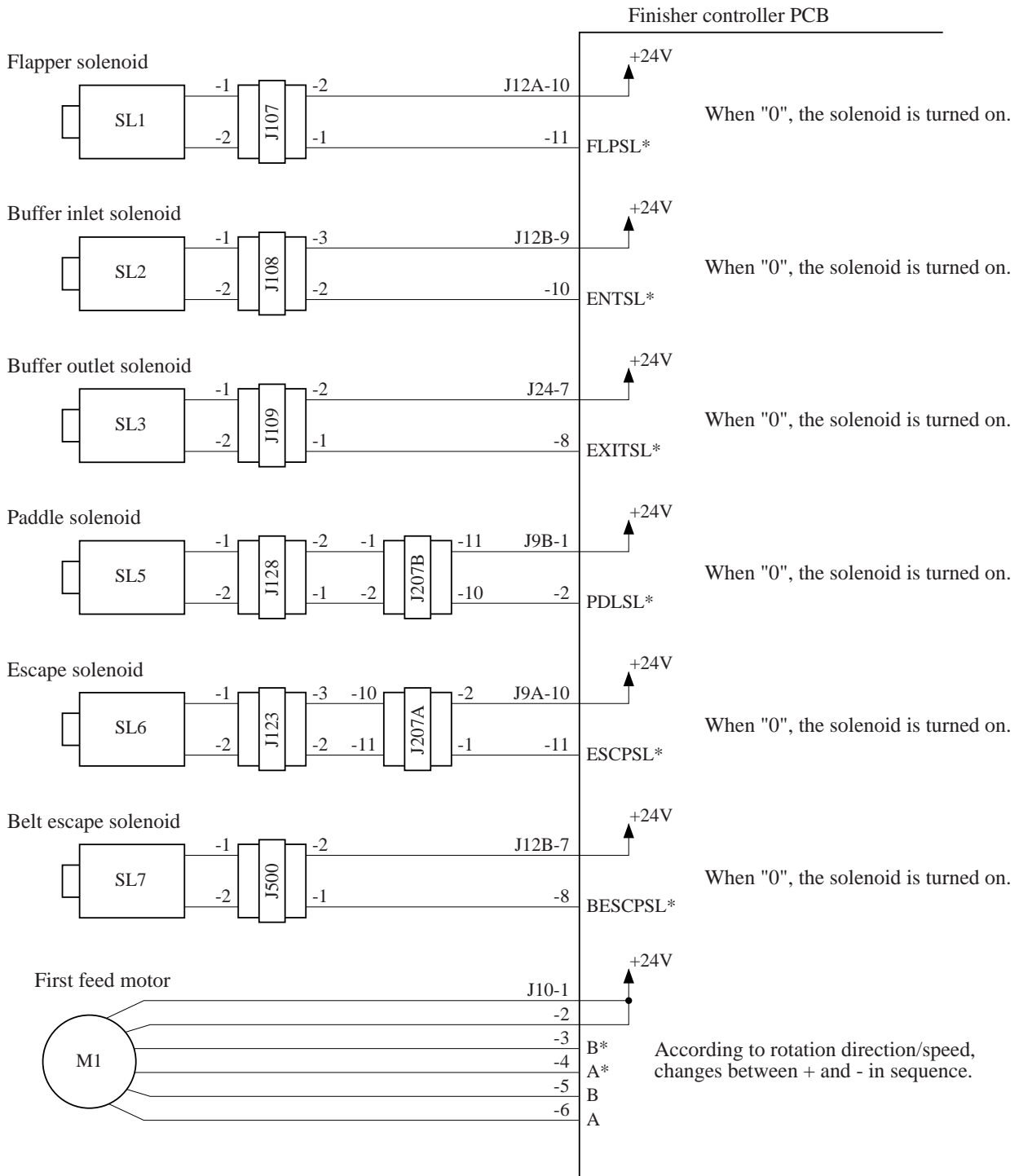

Figure 2-107

6. Outputs from the Finisher Controller PCB

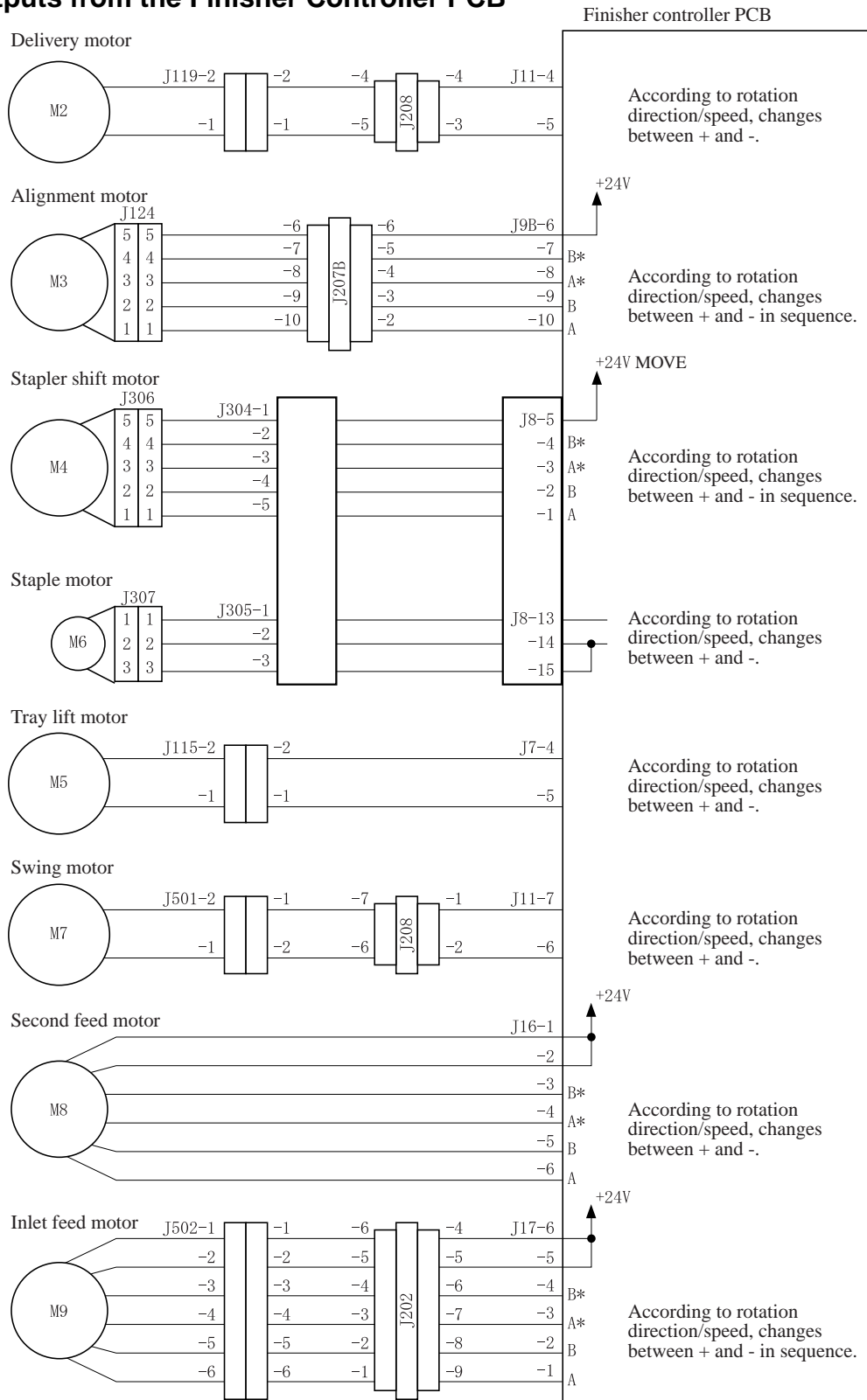

Figure 2-108

II. FEED/DRIVE SYSTEM

A. Outline

The finisher is designed to operate according to the commands from its host machine to deliver arriving copies to trays in the appropriate mode: simple stacking, job offset, stapling.

See Figure 2-201 for a diagram of the three modes of delivery (four for the Saddle Finisher).

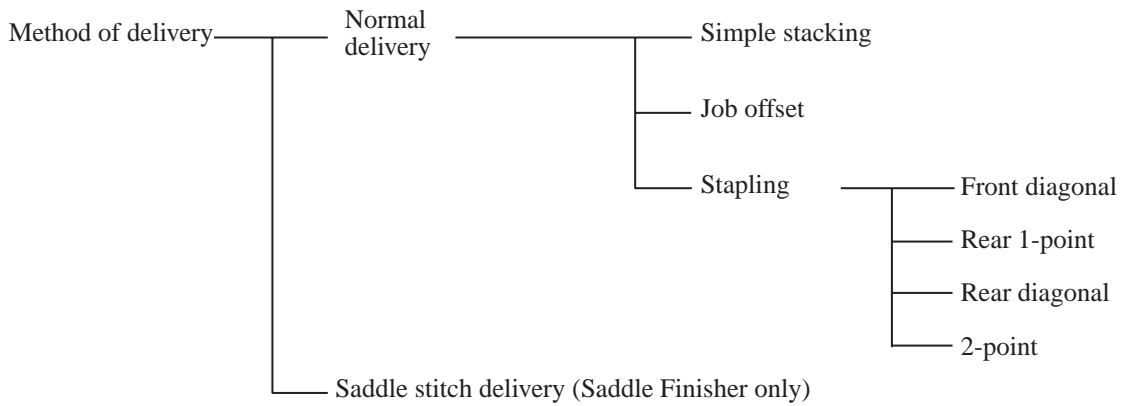

Figure 2-201

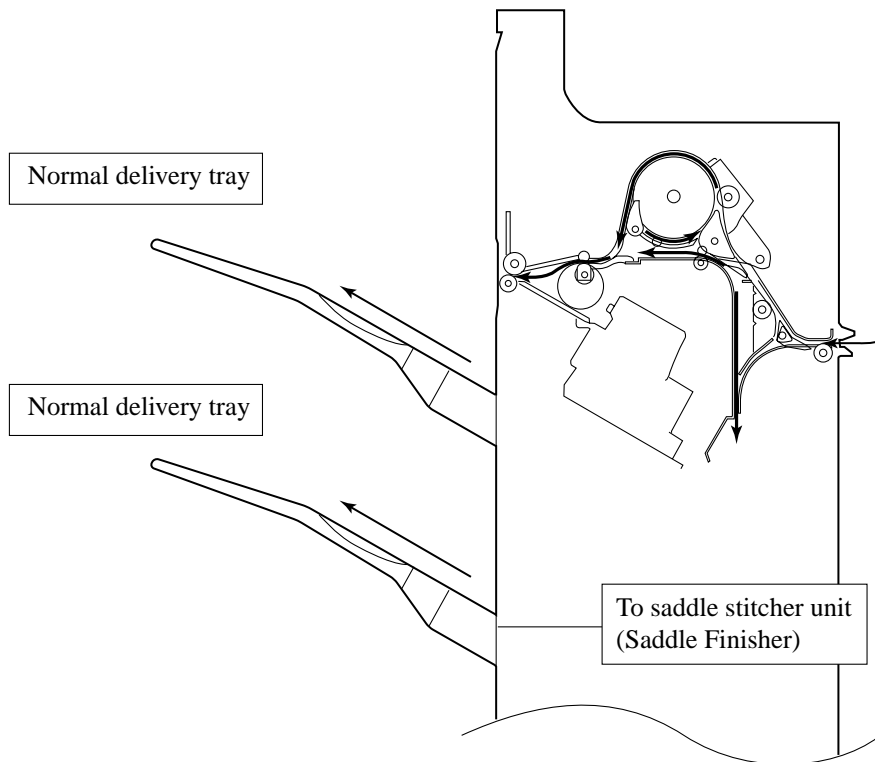

Figure 2-202

1. Normal Delivery

a. Simple Stacking

The finisher delivers copies directly to the tray.

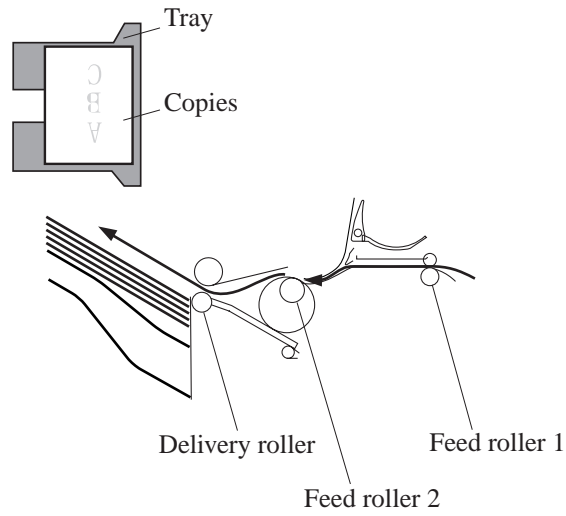

Figure 2-203

b. Job Offset

The finisher forwards all copies of each sort job to the stapling tray. The first sort job on the stapling tray is delivered with a shift to the front of about 30 mm, and the second sort job is delivered without being shifted. Whether the first copy or the last copy of a sort job should be shifted is determined by the host machine.

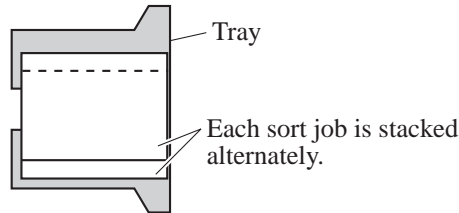

Figure 2-204

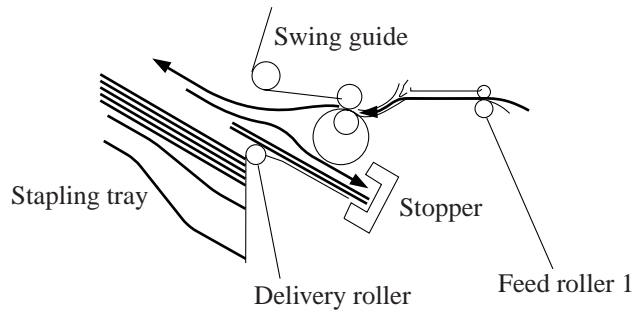

Figure 2-205

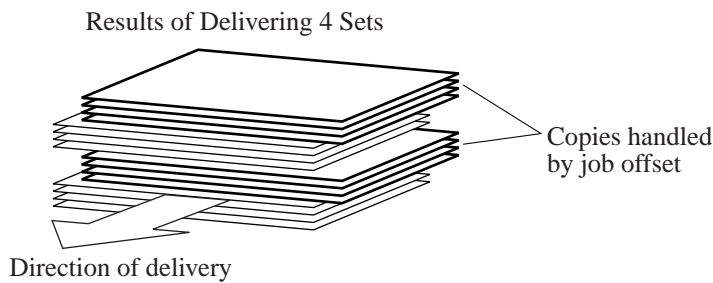

Figure 2-206

c. Stapling

The finisher stacks copies arriving from its host machine on the stapling tray. Then it staples and delivers the copies to the appropriate tray.

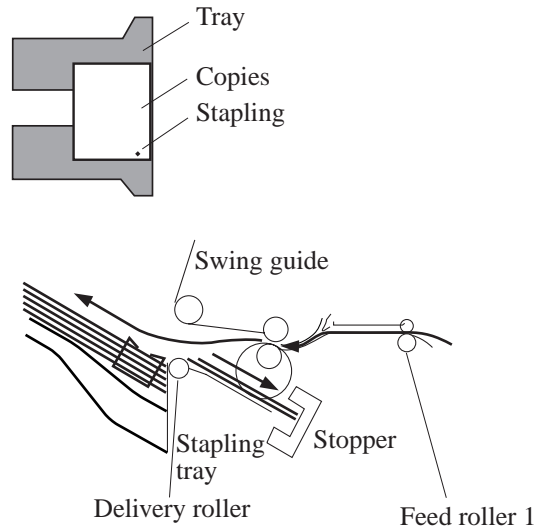

Figure 2-207

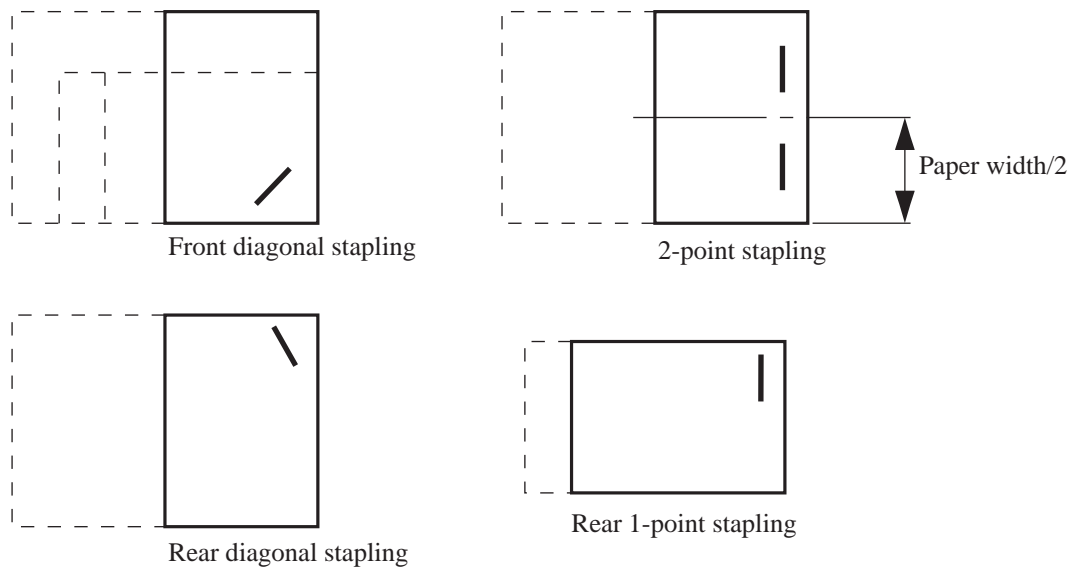

Figure 2-208

2. Saddle Stitch Delivery (Saddle Finisher)

A copy arriving in the finisher from the host machine is routed to the saddle stitcher by the paper deflecting plate. The saddle stitcher executes stitching and saddling operations on the copy and then delivers it to the saddle stitcher tray.

For discussions of stacks in the saddle stitcher, see Chapter 3.

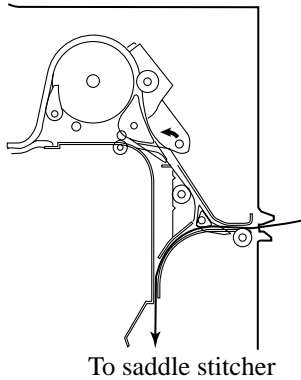

Figure 2-209

B. Type of Delivery Paths

The finisher has three different paper paths for delivery, each selected to suit paper size and delivery mode.

1. Straight Path

When stacking copies shown in Table 2-201, the copies pass under the buffer roller.

Copy size	Length or width 182 mm or less
Typical copy examples	A5-R, ST-R, thick stock

Table 2-201

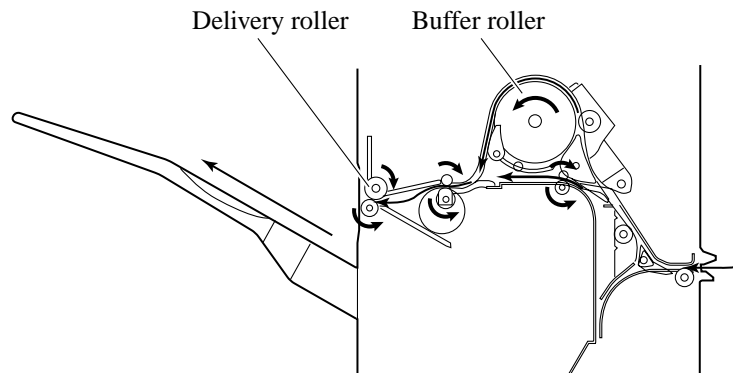

Figure 2-210

2. Buffer Paper Path 1

When stacking copies shown in Table 2-202, the copies pass over the buffer roller, increasing the distance between copies.

Copy size	Length and width 182 mm or more
Typical copy examples	A3, B4, A4, A4-R, B5, B5-R, LD, LG, LT, LT-R, (excluding transparencies and thick stock)

Table 2-202

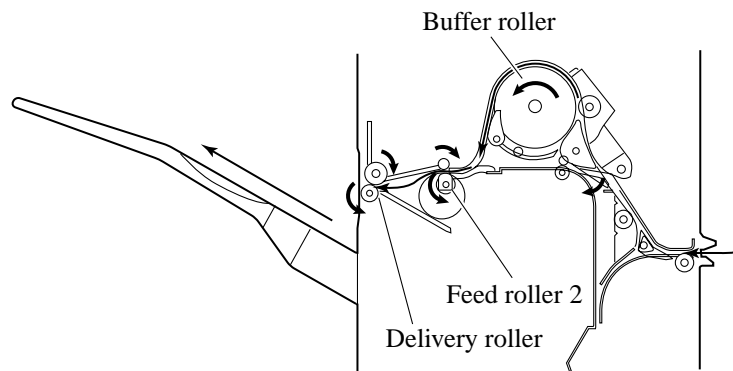

Figure 2-211

3. Buffer Paper Path 2

This is the paper path when copy sizes shown in Table 2-203 are stacked. A maximum of three copies (three originals or more in the stapling mode) are wrapped round the buffer roller, during which job offset and stapling are performed on the stapling tray.

Copy size	Length 182 to 232mm, and width 182 to 297mm
Typical copy examples	A4, B5, LT, (excluding transparencies and thick stock)

Table 2-203

The following shows paper delivery operation in the case of three originals in the stapling mode.

- 1) The first copy is moved in the direction of the buffer roller.

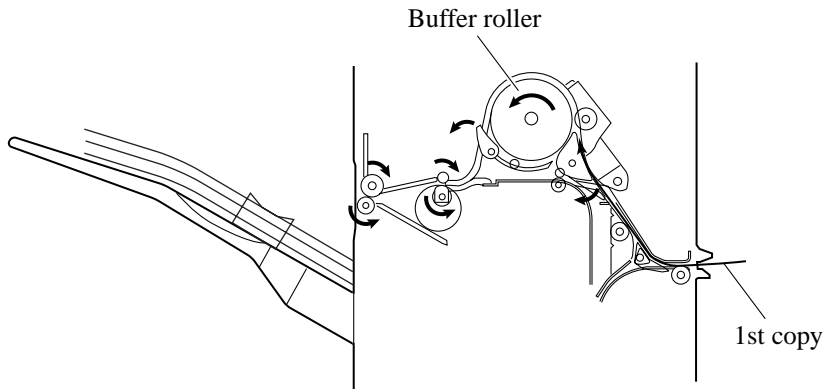

Figure 2-212

- 2) The first copy wraps around the buffer roller and, at the same time, the second copy arrives from the host machine.

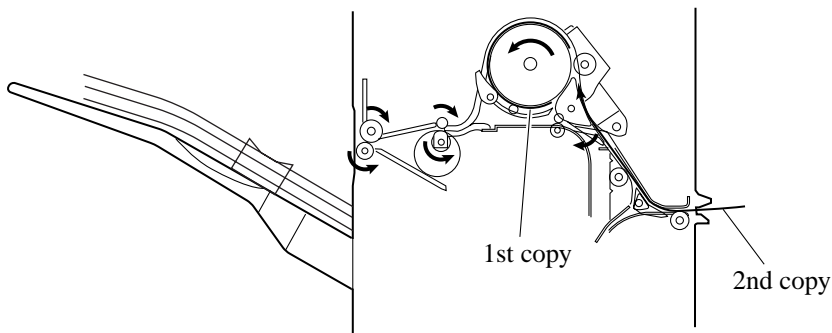

Figure 2-213

- 3) The second copy is laid over the first copy and, at the same time, the third copy arrives from the host machine.

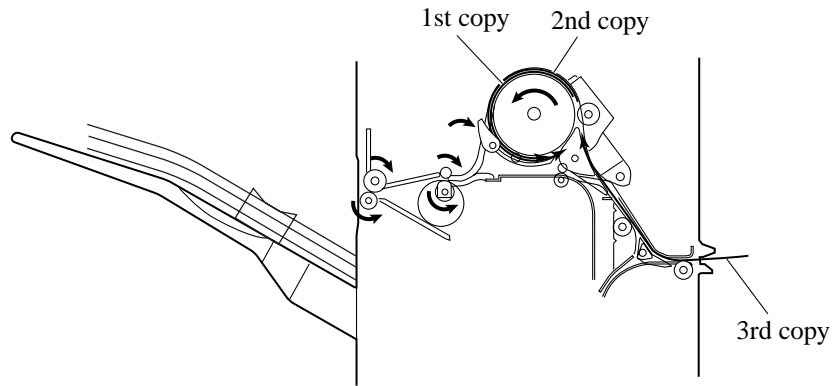

Figure 2-214

- 4) The first, second and third copies are simultaneously pulled into the stapling tray.

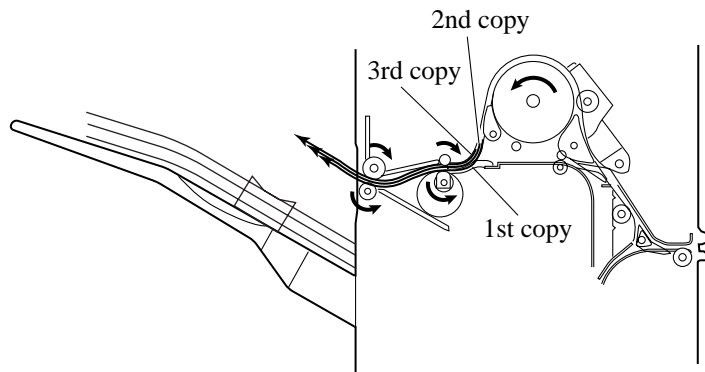

Figure 2-215

Note:

The third copy as explained here is moved through buffer paper path 1. This fact is omitted from the discussion to avoid interrupting the sequence of operations.

C. Feeding and Delivering

1. Outline

The finisher moves copies arriving from the host machine to the delivery tray, stapling tray, or the saddle stitcher unit (Saddle Finisher) according to the mode of delivery. On the stapling tray, the copies are subjected to job offset or stapling as instructed by the host machine.

The first feed motor (M1), second feed motor (M8) and inlet feed motor (M9) are stepping motors, and delivery motor (M2) is a DC motor. These motors are controlled by the microprocessor (CPU) on the finisher controller PCB, and rotate either clockwise or counterclockwise.

The paper paths are equipped with the following four sensors for detection of paper (arrival, passage):

- Inlet sensor (PI1)
- Delivery sensor (PI3)
- Stapling tray sensor (PI4)
- Buffer path paper sensor (PI14)

In addition, each delivery tray is equipped with a sensor designed to detect the presence/absence of paper on it.

- No.1 tray paper sensor (PI11)
- No.2 tray paper sensor (PI12)

If a copy fails to reach or move past each sensor within a specific period of time, the finisher controller PCB identifies the condition as a jam, and stops the ongoing operation and at the same time informs the host machine of the condition. When all doors are closed after the paper jam is removed, the buffer path inlet paper sensor (PI17) checks whether or not copies are being detected in addition to the above four sensors (inlet sensor, delivery sensor, stapling tray sensor and buffer path paper sensor). If the sensors detect a copy, the finisher unit judges that paper jams have not completely been removed, and sends the paper jam removal signal to the host machine again.

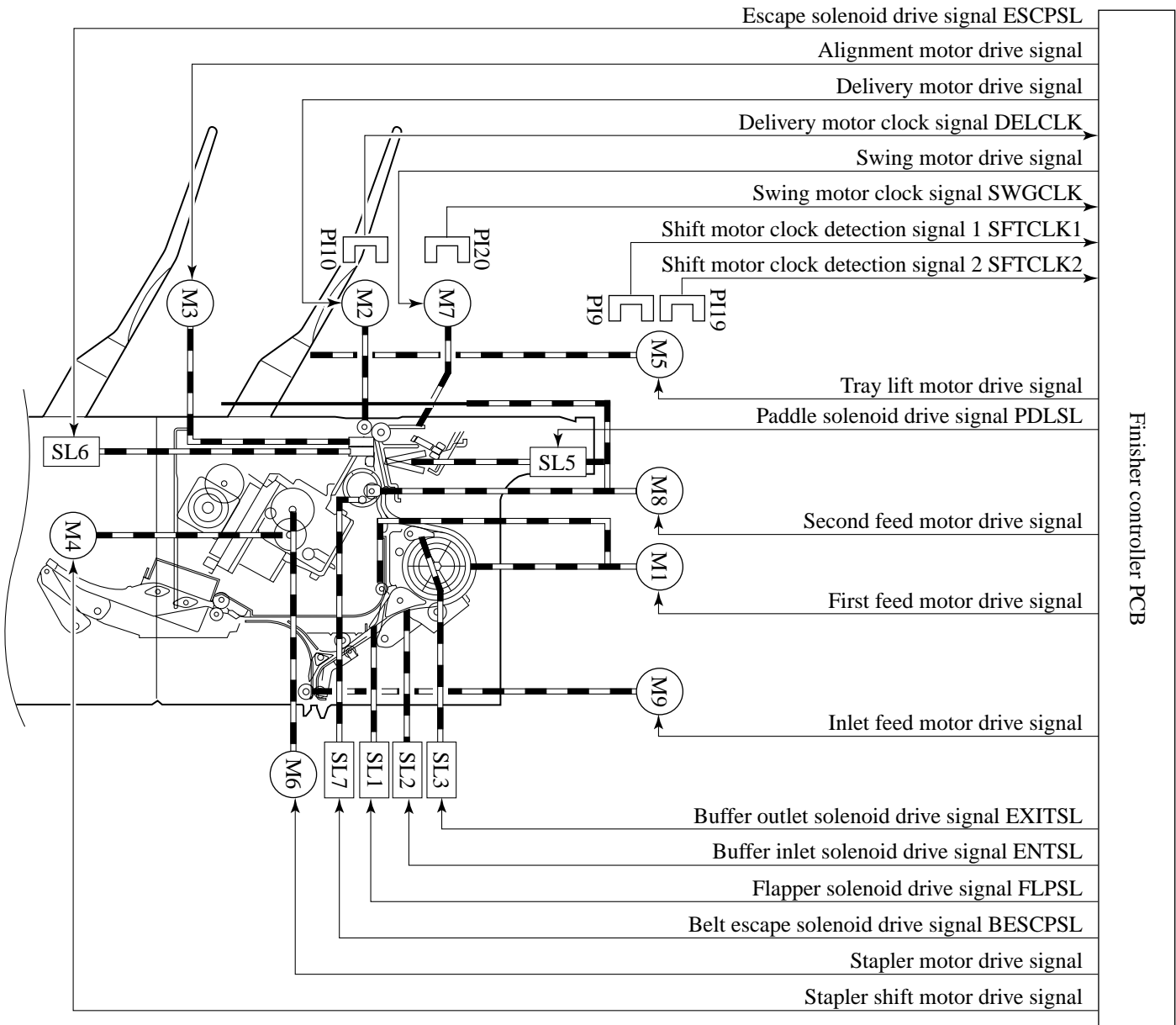

Figure 2-216

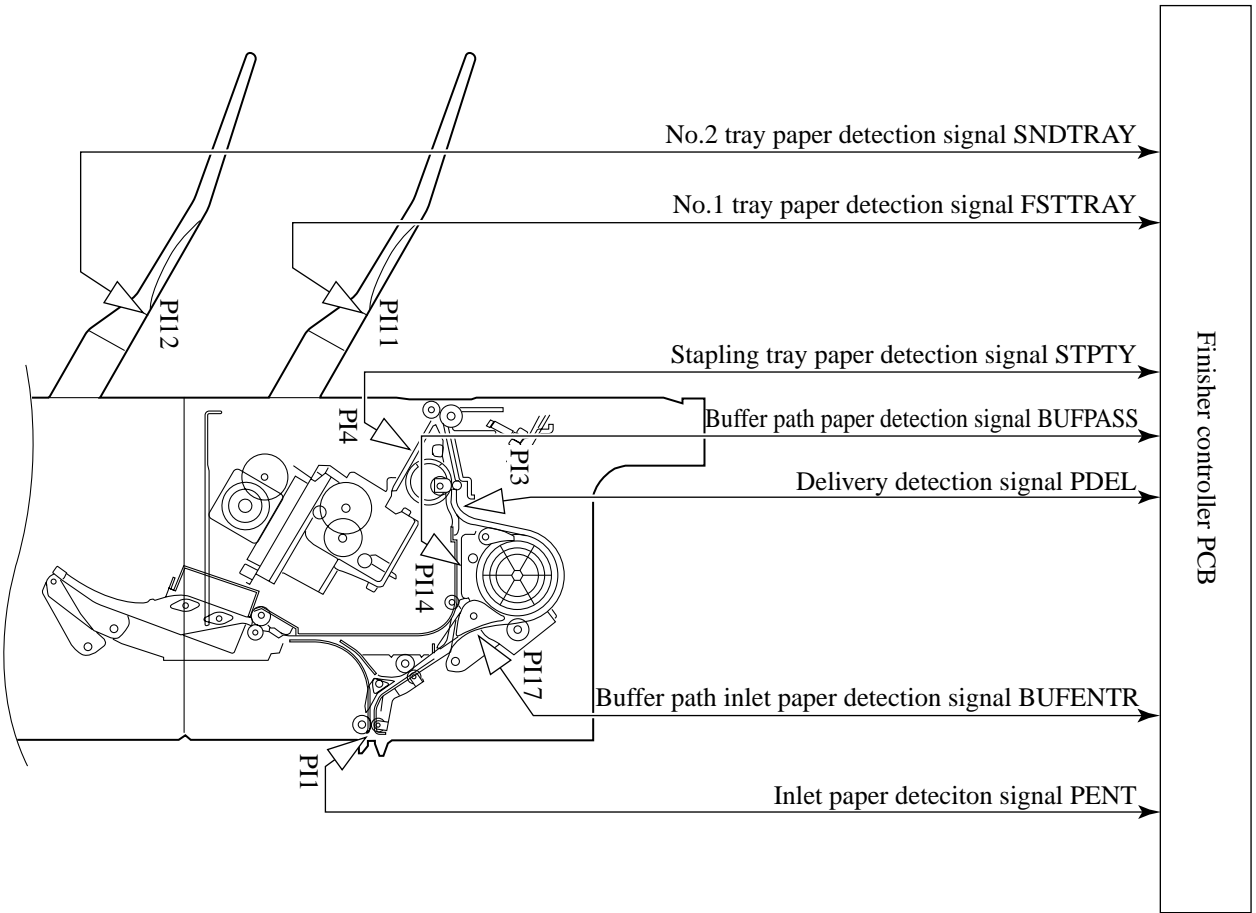

Figure 2-217

D. Job Offset

1. Outline

In the job offset mode, sort jobs and entire copy groups are shifted to the front for delivery to the tray, and other copies are delivered to the tray without a shift.

The copies are shifted by the alignment guide. The alignment guide is checked by the alignment home position sensor (PI6) to find out whether it is at the home position.

The finisher controller PCB drives the alignment motor (M3) at power-on to return the alignment guide to its home position.

The finisher controller PCB stops the delivery motor (M2) when the trailing edge of the copy has moved past feed roller 2. Then the finisher controller PCB rotates the delivery motor counterclockwise and drives the swing motor (M7). As a result, the drive of the delivery motor is transmitted to the swing guide to move up the guide. When the swing guide open sensor (PI18) detects the swing guide, the delivery motor stops, and the swing guide is held at the up position.

When the swing guide has moved up, the knurled belts attached to feed roller 2 move the copy to the stapling tray. The presence of paper on the stapling tray is monitored by the stapling tray sensor (PI4). (The first sheet is fed to the stapling tray while the swing guide is moving up.)

The finisher controller PCB drives the alignment motor (M3) in advance, and keeps the alignment guide in wait at a point 10 mm behind the trailing edge of a sheet. Whenever one sheet is moved to the stapling tray, each sheet is aligned, and when the fifth or last sheet in a sort job/group is fed to the stapling tray, the escape solenoid (SL6) moves the guide plate away and under the stapling tray. From then on, the alignment motor shifts the sheets to the front by 30 mm.

When the copy has been shifted, the finisher controller PCB rotates the alignment motor counterclockwise to move the alignment guide to a point 7 mm behind the trailing edge of the sheet. This alignment operation is repeated until alignment of the fifth or last sheet in a sort job is completed. At this time, the swing guide is moved down and is closed, and the delivery motor rotates clockwise to deliver the sheet.

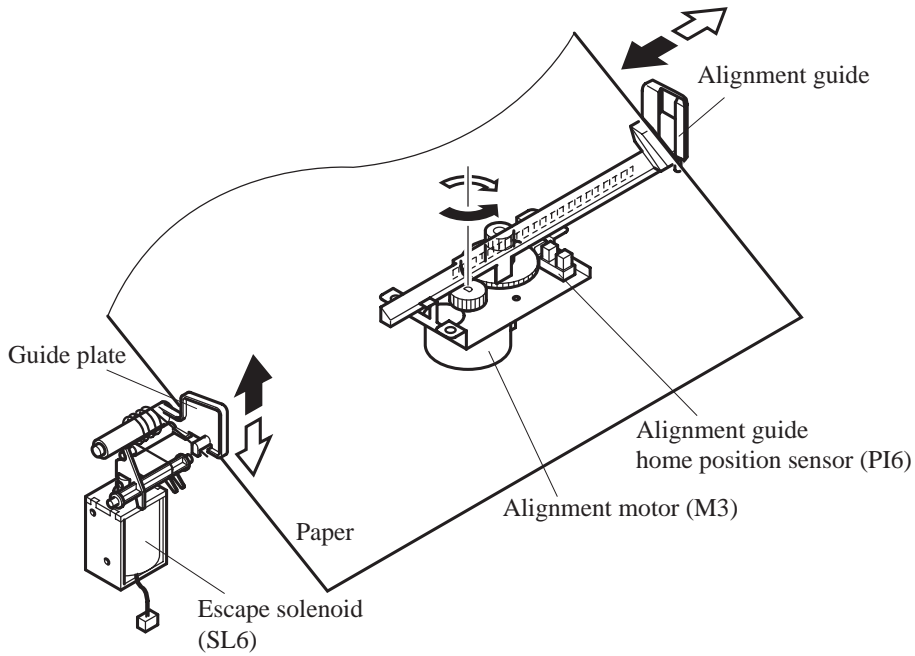

Figure 2-218

Sequence of Operation (job offset)

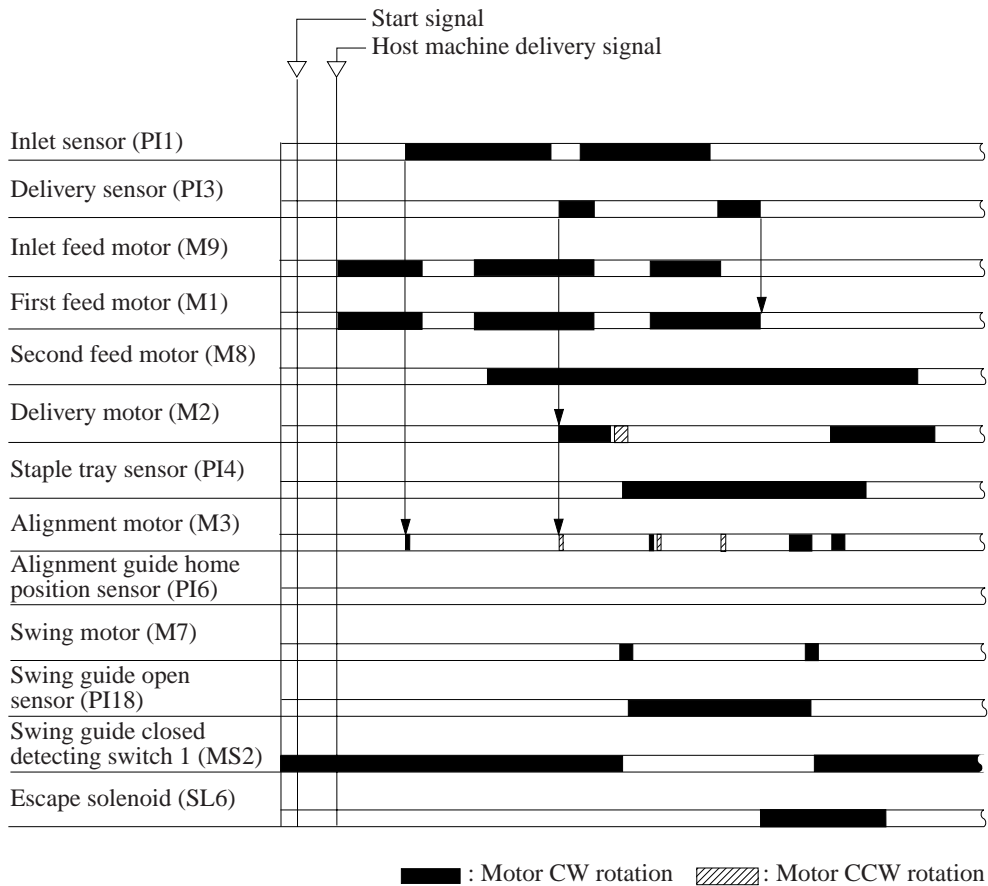

Figure 2-219

2. Flow of Job Offset Operations

- 1) The swing guide moves up and, at the same time, the knurled belts move the sheet to the stapling tray.

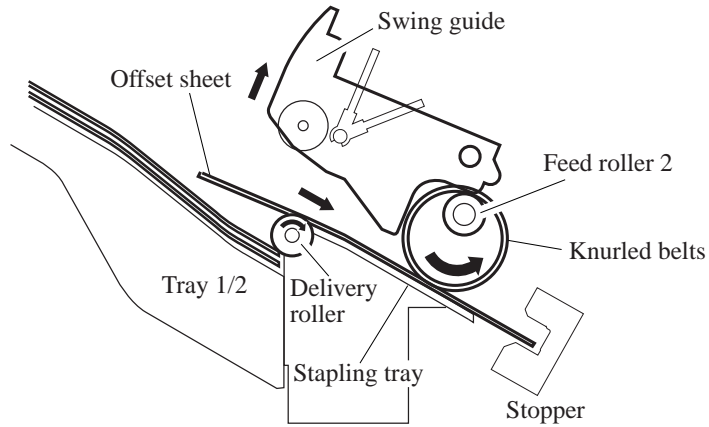

Figure 2-220

- 2) The alignment guide shifts the sheet to the front.

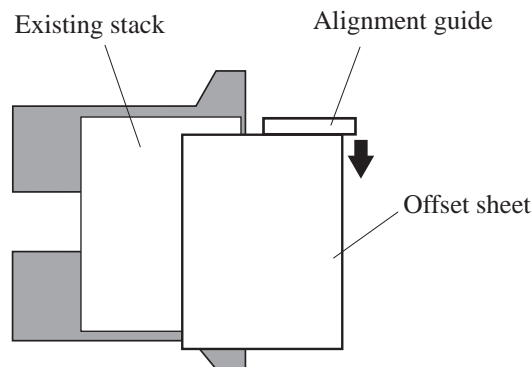

Figure 2-221

- 3) The swing guide moves down and, at the same time, the delivery roller delivers the sheet.

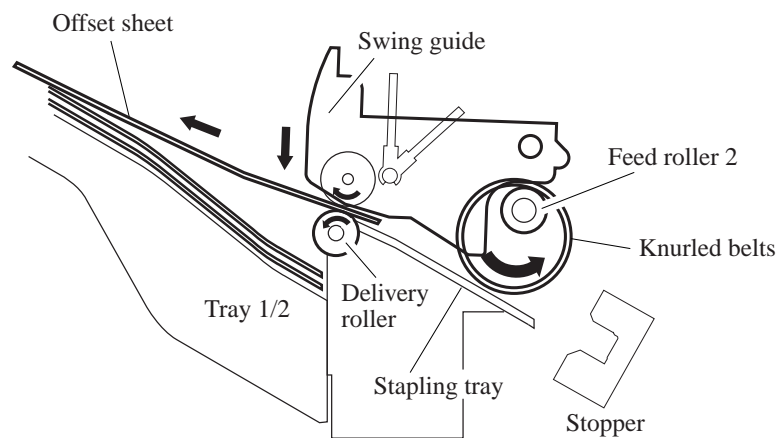

Figure 2-222

E. Stapling Operation

1. Outline

The stapler unit staples a stack of as many sheets as specified.

The stapling position differs according to the selected staple mode and paper size.

The stapler unit is checked by the stapler shift home position sensor (PI7) to find out whether it is at the home position.

When starting operation after power-on, the finisher controller PCB drives the stapler shift motor (M4) to return the stapler unit to the home position. If the stapler is already at the home position, it is kept waiting as it is.

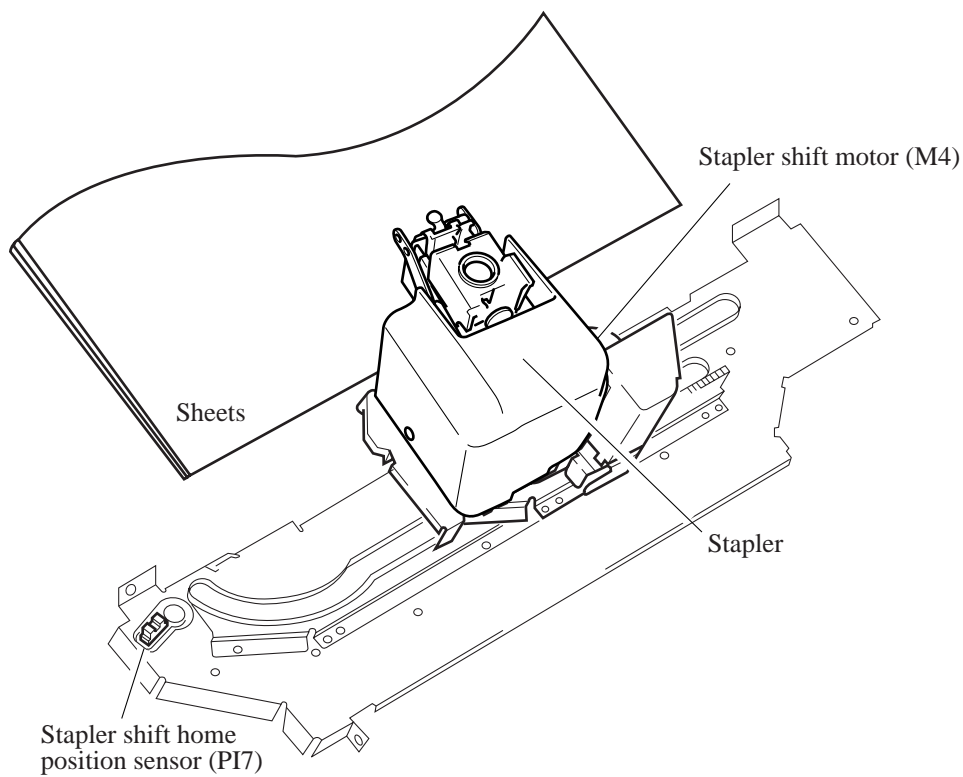

Figure 2-223

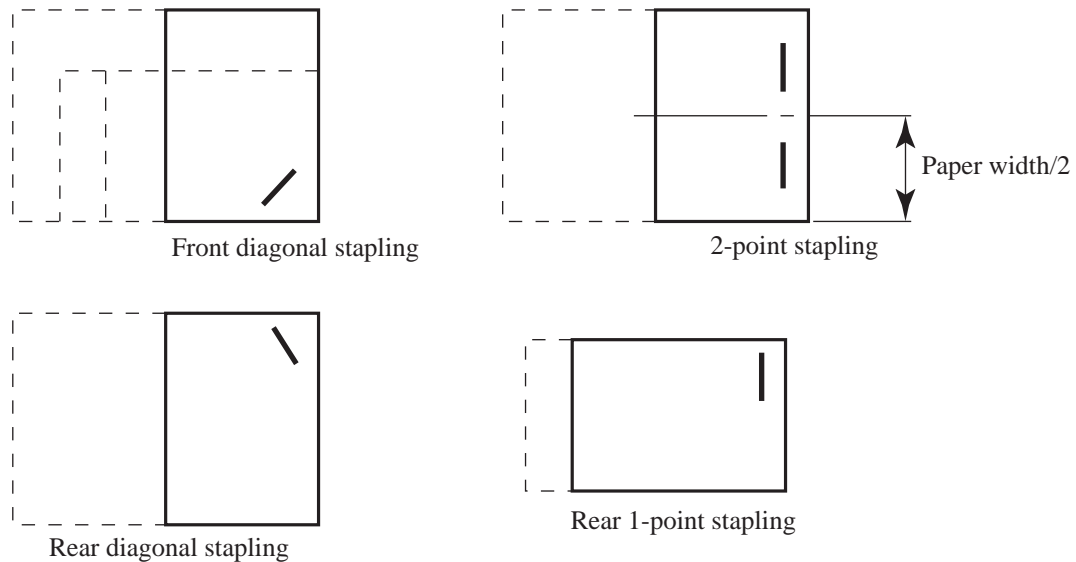

Figure 2-224

2. First Sheet

The finisher controller PCB stops the delivery motor (M2) as soon as the trailing edge of the first sheet has moved past feed roller 2. Then it rotates the delivery motor clockwise to switch the gear drive to the swing motor (M7), causing the swing guide to move up. When the swing guide open sensor (PI18) finds the swing guide at the up position, the swing motor stops, maintaining the swing guide at the up position.

When the swing guide has moved up, the feed belts of feed roller 2 move the sheet to the stapling tray. (The first sheet is fed to the stapling tray while the swing guide is moving up.) The presence of paper on the stapling tray is detected by the stapling tray sensor (PI4).

The finisher controller PCB drives the alignment motor (M3) when the stapling tray sensor has detected paper to put sheets in order. The alignment plate is kept waiting in advance at a point 10 mm behind the trailing edge of the paper.

The swing guide is kept waiting at the up position until the last sheet is output onto the stapling tray.

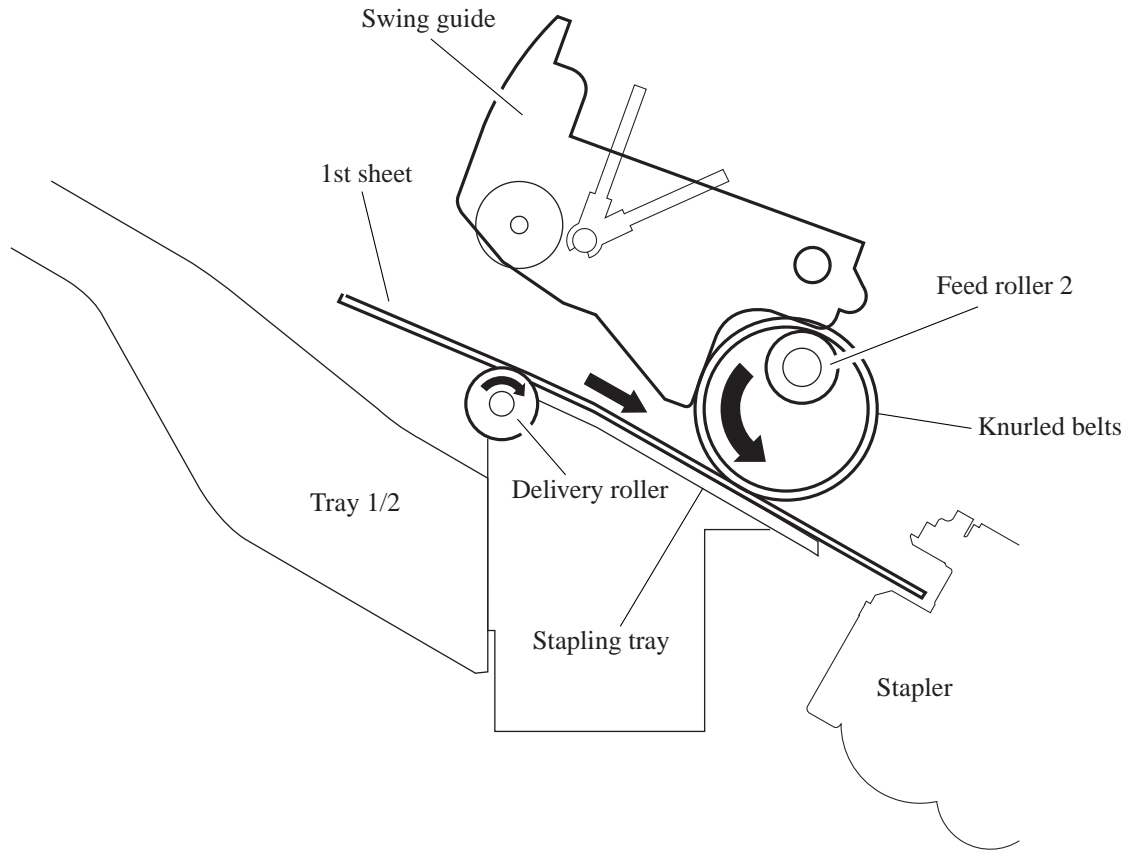

Figure 2-225

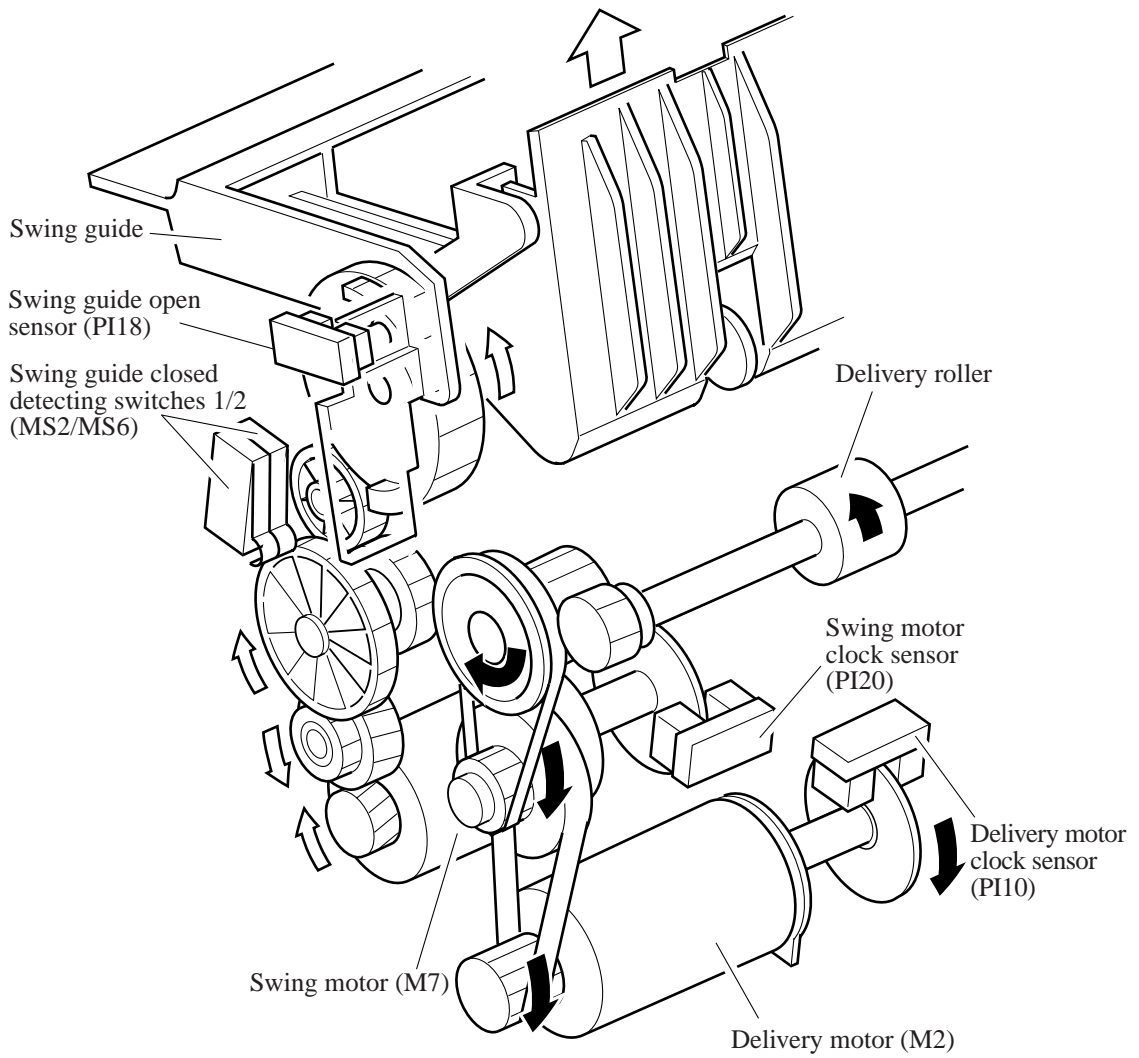

Figure 2-226

3. 2nd and Subsequent Sheets

The finisher controller PCB turns on the belt escape solenoid (SL7) before the trailing edge of the second and subsequent sheets have moved past feed roller 2 to make the feed belt escape. This operation is performed to reduce the time it takes for the trailing edge of the paper to fall on the stapling tray, and to improve the product duty. The finisher controller PCB turns on the paddle solenoid (SL5) as soon as the trailing edge of the second and subsequent sheets have moved past feed roller 2, causing the drive of the second feed motor (M8) to rotate the paddle. The sheets are pushed by the paddle and moved to the stapling tray. Almost simultaneously with the trailing edge of the sheet falling into the stapling tray, the belt escape solenoid is turned off to return the feed belts that were in the escape position to their original position, and feed the sheet onto the stapling tray. When the sheet has been output onto the the stapling tray, the finisher controller PCB rotates the alignment motor (M3) to put the sheets in order.

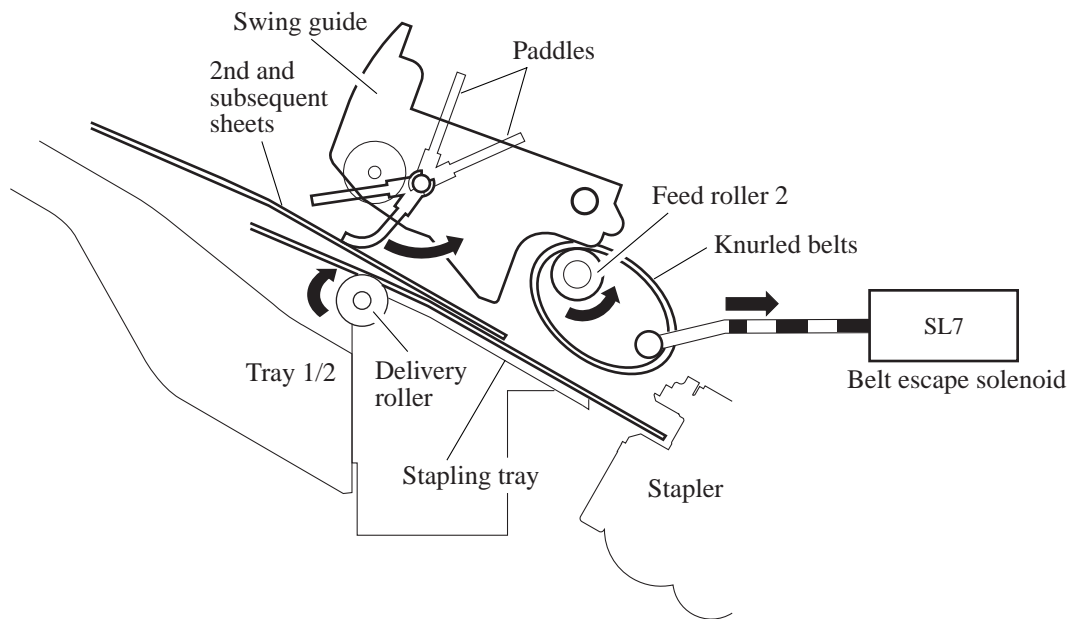

Figure 2-227

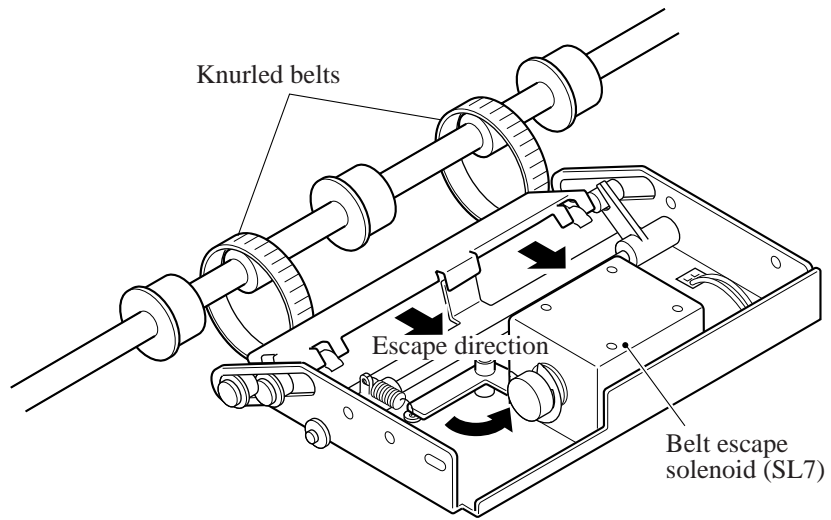

Figure 2-228

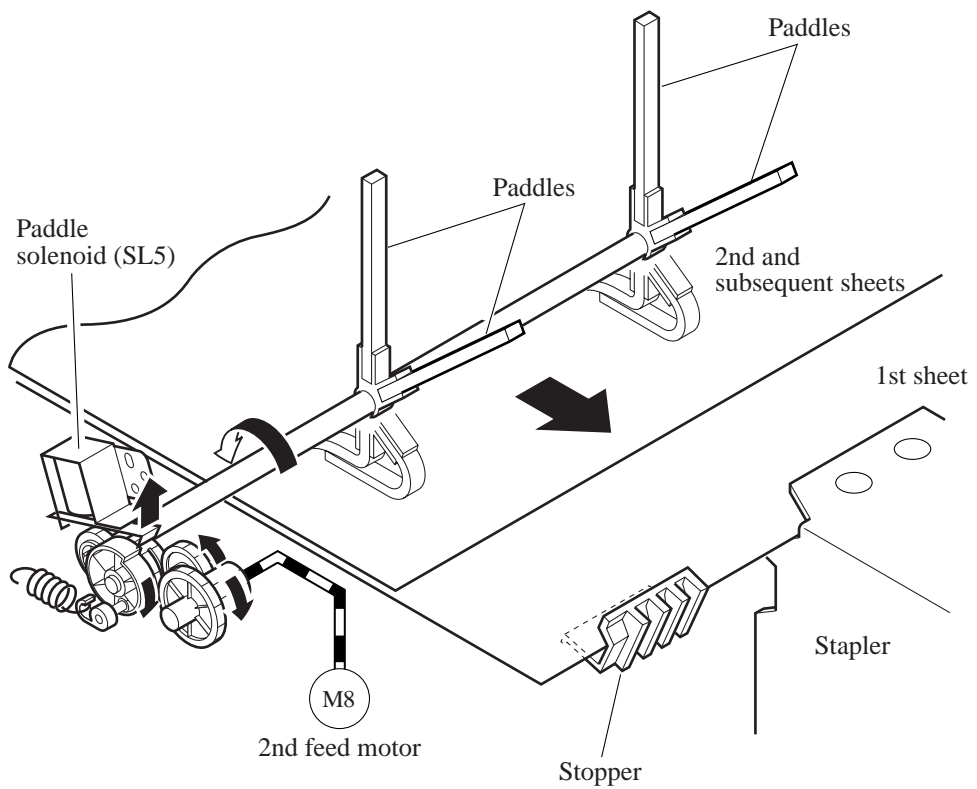

Figure 2-229

4. Last Sheet

When the last sheet has been put in order, the finisher controller PCB turns on the alignment motor (M3) to move the alignment guide to the alignment position (to butt the guide against the stack). Then, the finisher controller PCB rotates the swing motor (M7) counterclockwise to move the swing guide downwards.

The finisher controller PCB moves the stapler according to the staple mode for stapling.

From then on, it rotates the delivery motor (M2) clockwise to delivery the stack to the tray.

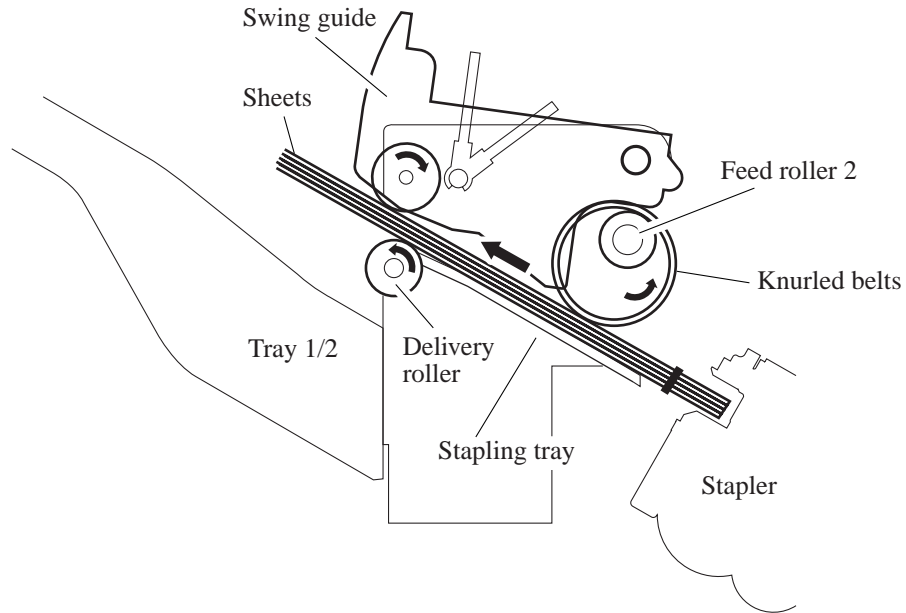

Figure 2-230

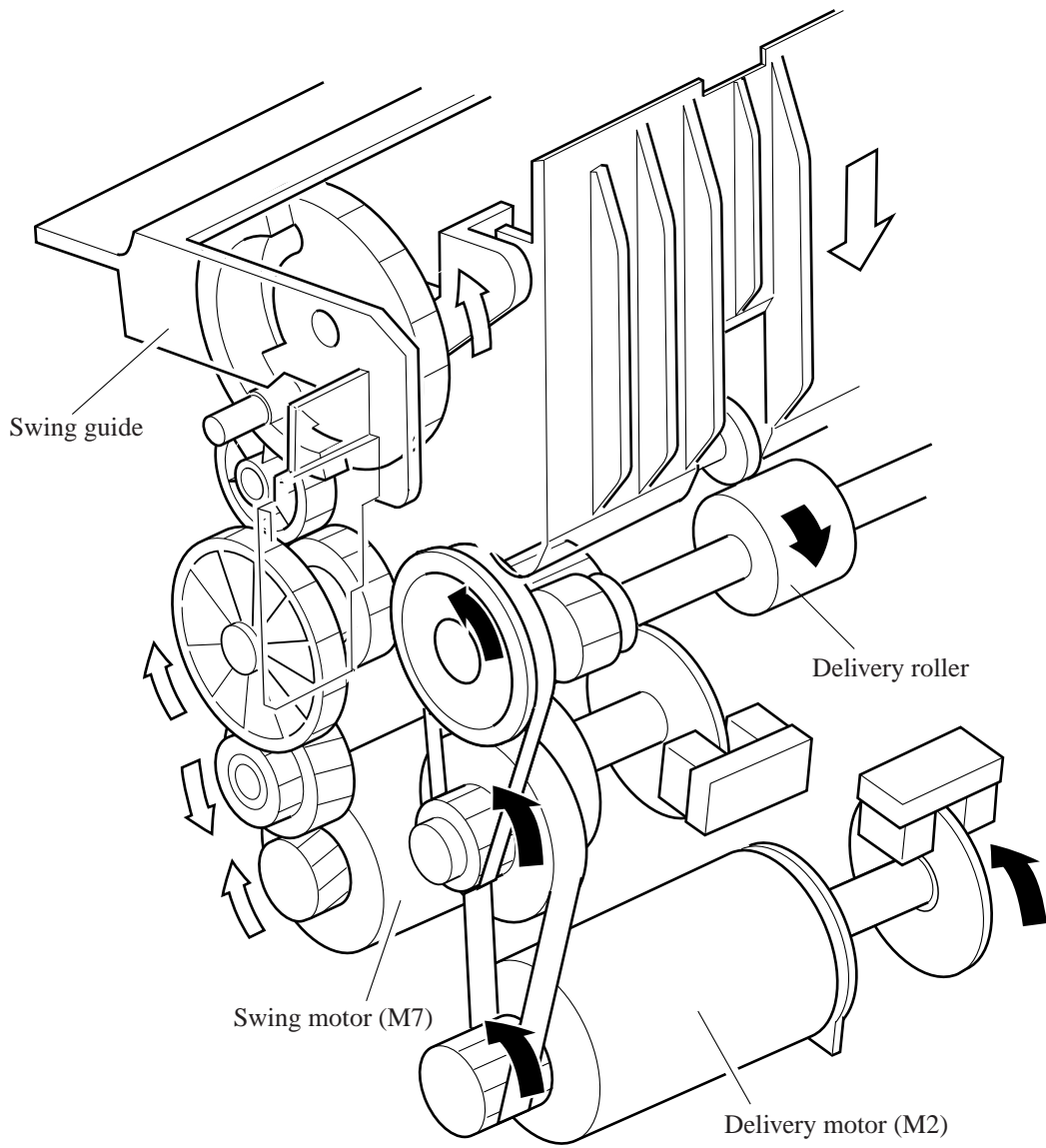

Figure 2-231

F. Stapler Unit

Stapling is executed by the stapler motor (M6). A single rotation of the cam by the motor results in one stapling operation.

The cam is checked by the stapling home position sensor (PI22) to find out whether it is at the home position.

The stapler motor is controlled by the microprocessor (Q1) on the finisher controller to enable it to be rotated clockwise or counterclockwise.

When the stapling home position sensor is off, the finisher controller PCB rotates the stapler motor clockwise until the sensor is turned on so as to return the stapling cam to its initial state.

The presence/absence of staples inside the staple cartridge is detected by the staple switch (MS8).

The finisher controller PCB does not drive the stapler motor (M6) unless the swing guide closed detecting switch 2 (MS6) is on (i.e., the swing guide is closed). This is to guard against injuries that could occur when a finger is stuck inside the stapler.

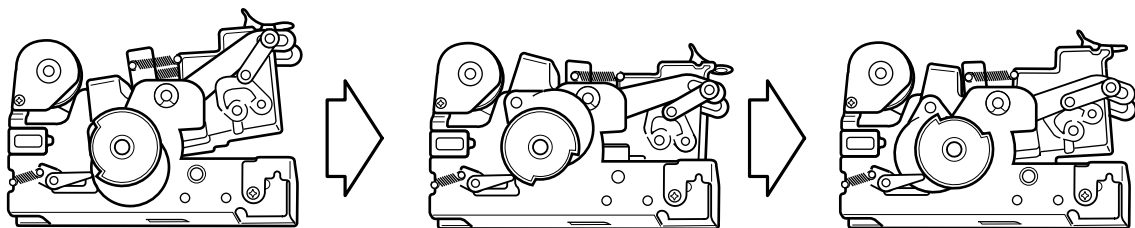

Figure 2-232

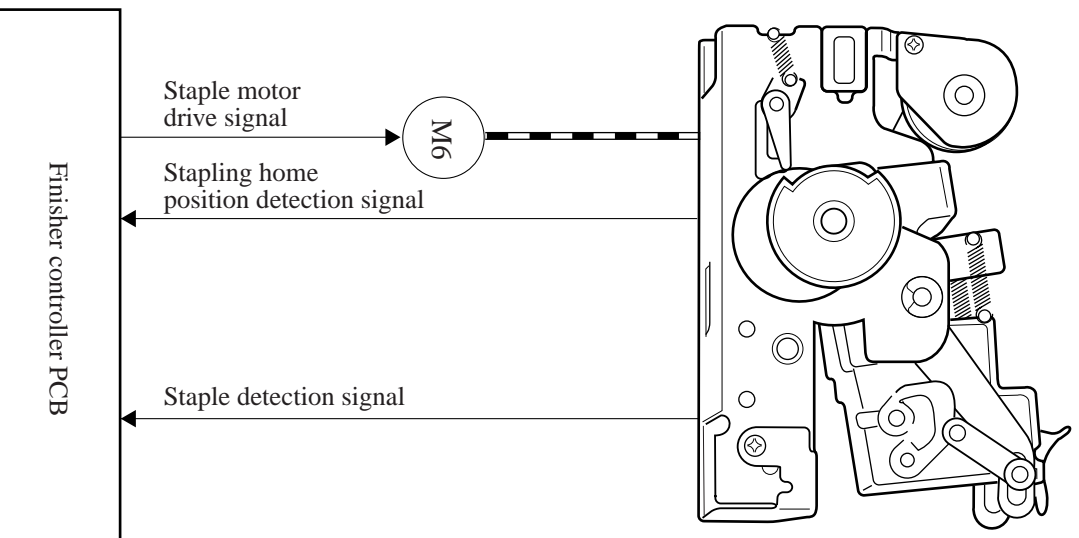

Figure 2-233

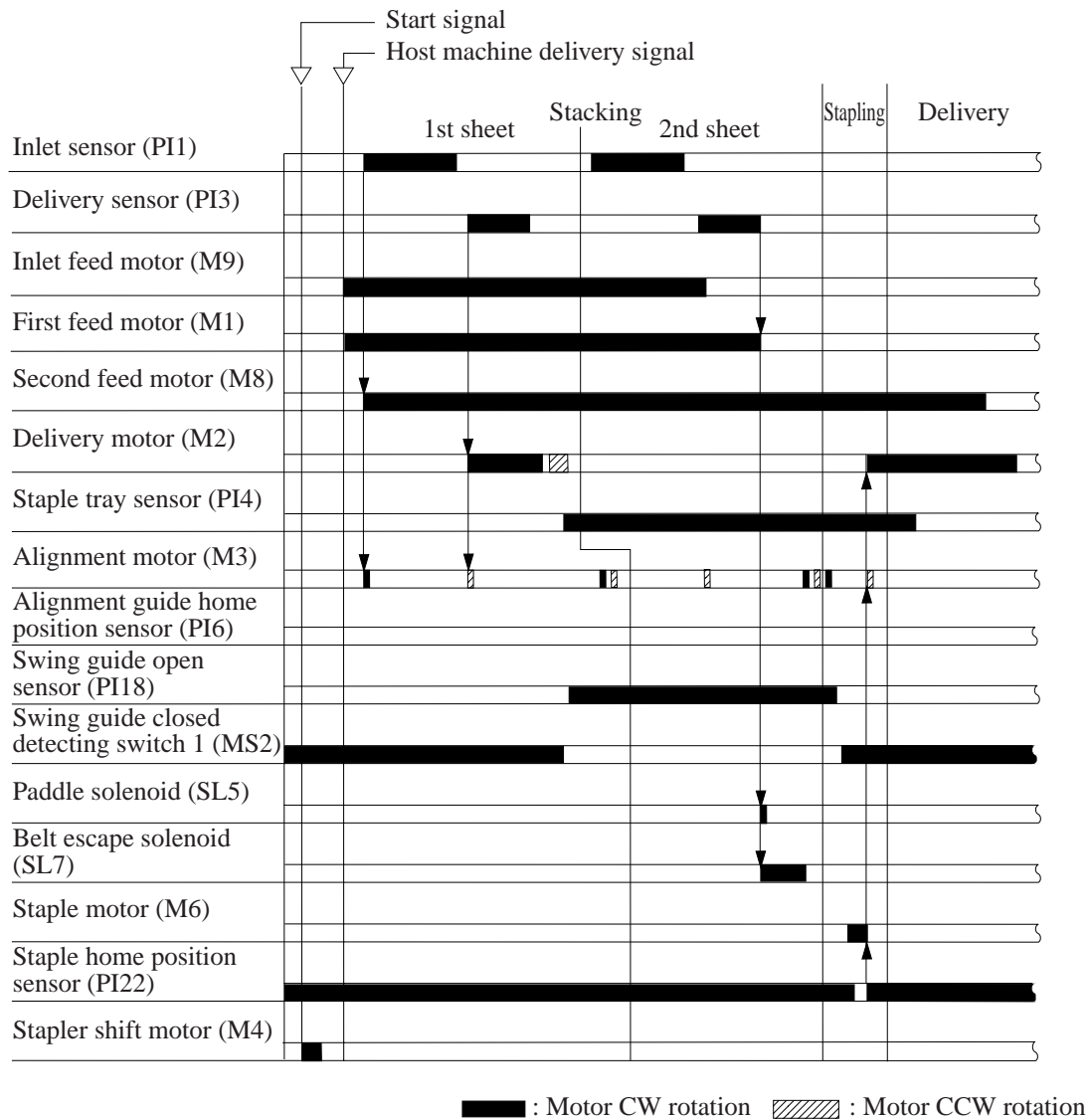

Figure 2-234

5. Shifting the Stapler Unit

The stapler unit is moved by the stapler shift motor (M4). Its home position is detected by the stapler shift home position sensor (PI7). When the start signal arrives from the host machine, the stapler moves to the center of its movement range. This movement occurs regardless of the selected mode of delivery, as no specific mode is recognized at this point in time. When the command for stapling arrives from the host machine after the first sheet has reached the host machine pre-registration sensor, the stapler moves to the staple wait position to suit the appropriate stapling position and paper size.

See Figures 2-235 and later for an idea of the waiting position according to the stapling mode.

a. Front Diagonal Stapling

The position is the same as the stapling position.

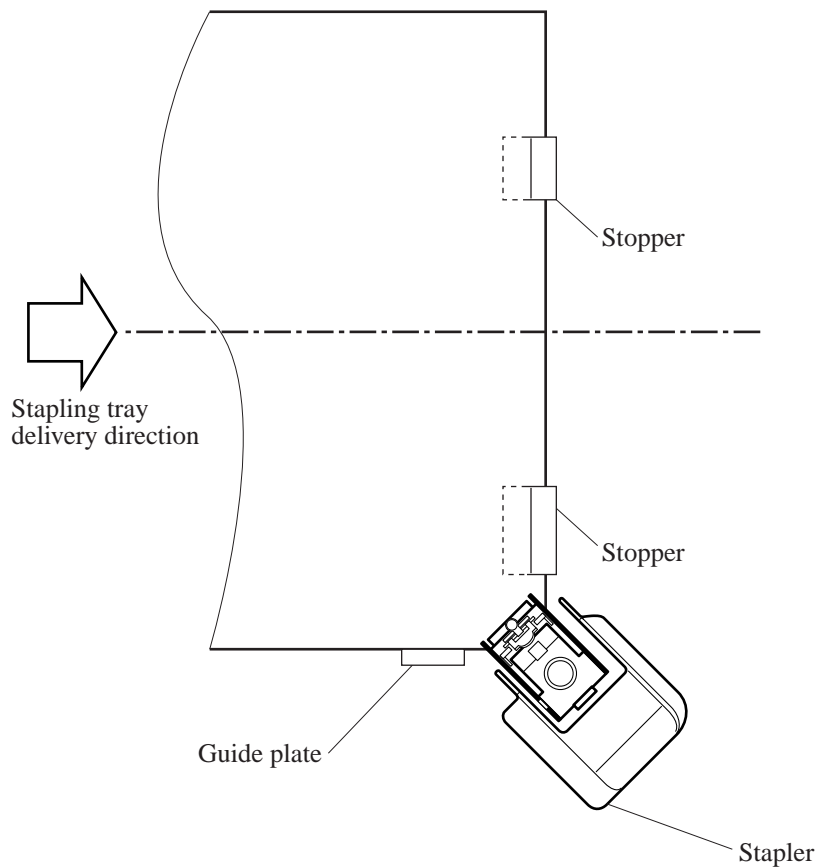

Figure 2-235

b. Rear 1-Point Stapling

The stapler is kept waiting at the center position. The stapler is moved to and from the stapling position for each stapling operation.

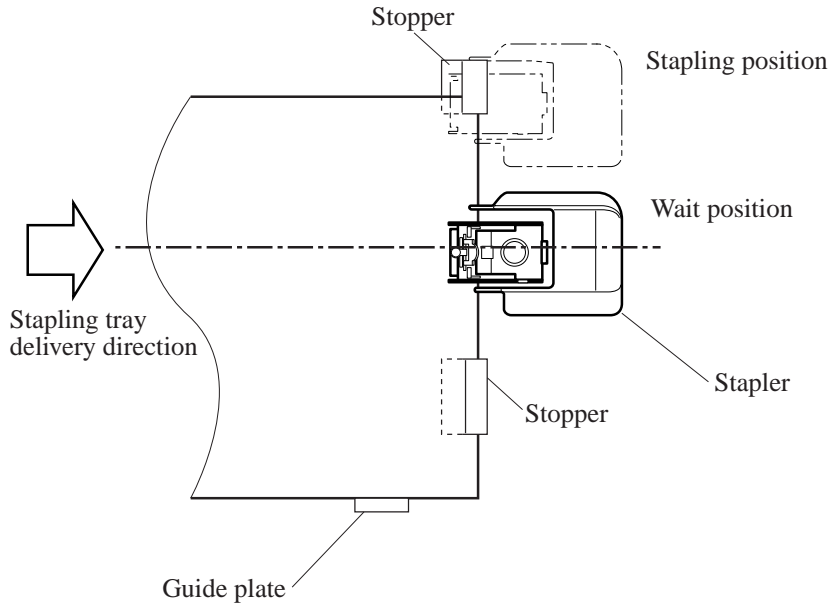

Figure 2-236

c. Rear Diagonal Stapling

For LT and B5 sizes, the stapler is kept waiting toward the rear away from the stapling position. The stapler is moved to and from the stapling position for each stapling operation.

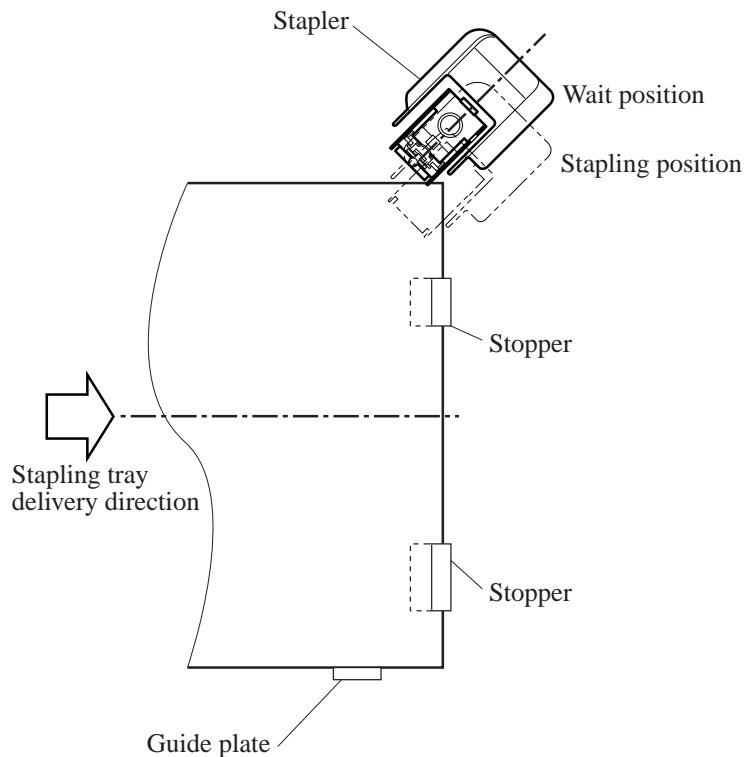

Figure 2-237

d. 2-Point Stapling

The stapler is kept waiting at the center of paper. Stapling occurs at two points, first at the rear and then at the front.

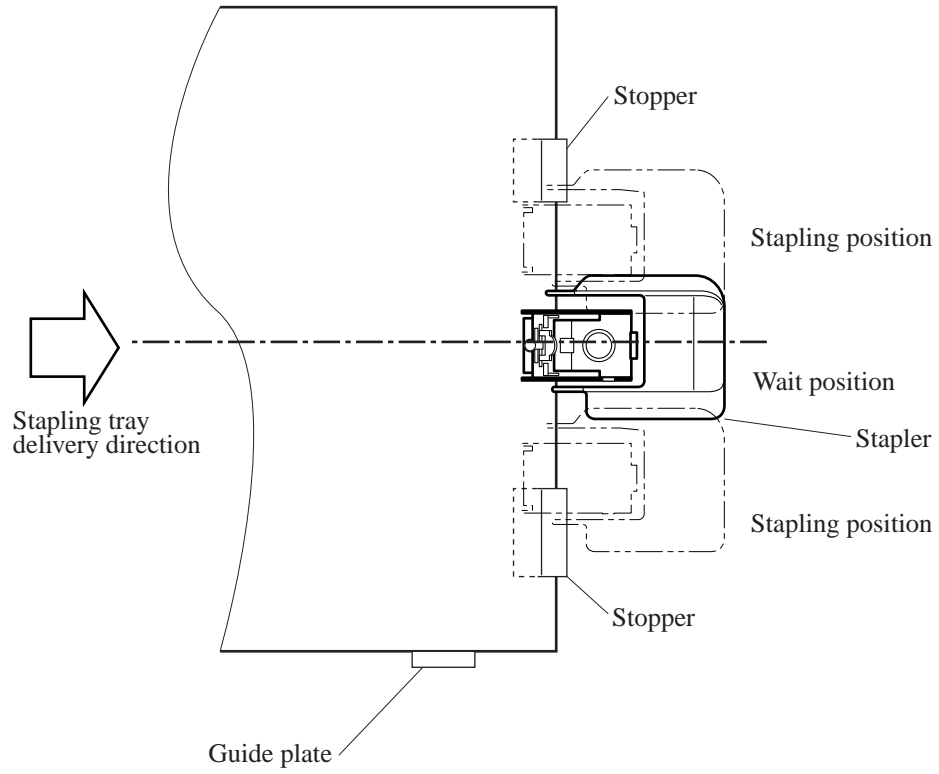

Figure 2-238

G. Tray Operation

The finisher has two delivery trays for normal delivery, each accepting sheets.

Each tray is moved up and down by the tray lift motor (M5).

The position of tray is identified with reference to the number of clock pulses of the tray lift motor clock sensor 1/2 (PI9/PI19) coming from the tray home position sensor (PI8). The finisher controller PCB finds out in which direction (up or down) the tray is moving based on combinations of pulses from the two clock sensors.

The finisher controller PCB drives the tray lift motor (M5) to return the tray to the home position at power-on. If the tray is already at the home position, it is kept waiting as it is.

The finisher controller PCB moves up and down the tray selected by the host machine so that it is positioned at the delivery slot.

The upper limit of the tray is detected by the tray upper limit detecting switch (MS5). The finisher controller PCB stops the drive (up) of the tray lift motor (M5) as soon as the tray upper limit detecting switch is turned on.

The height of the stack on the tray is identified by the height sensor (PS1), which measures its distance from the top of the stack. The tray is moved down when the distance between the top of the stack and the delivery assembly drops to a specific measurement.

The finisher controller PCB cuts off the +24V power of the tray lift motor (M5) as soon as the safety zone switch (MS3) is turned on while the shutter and the swing guide are open, stopping the operation of the finisher.

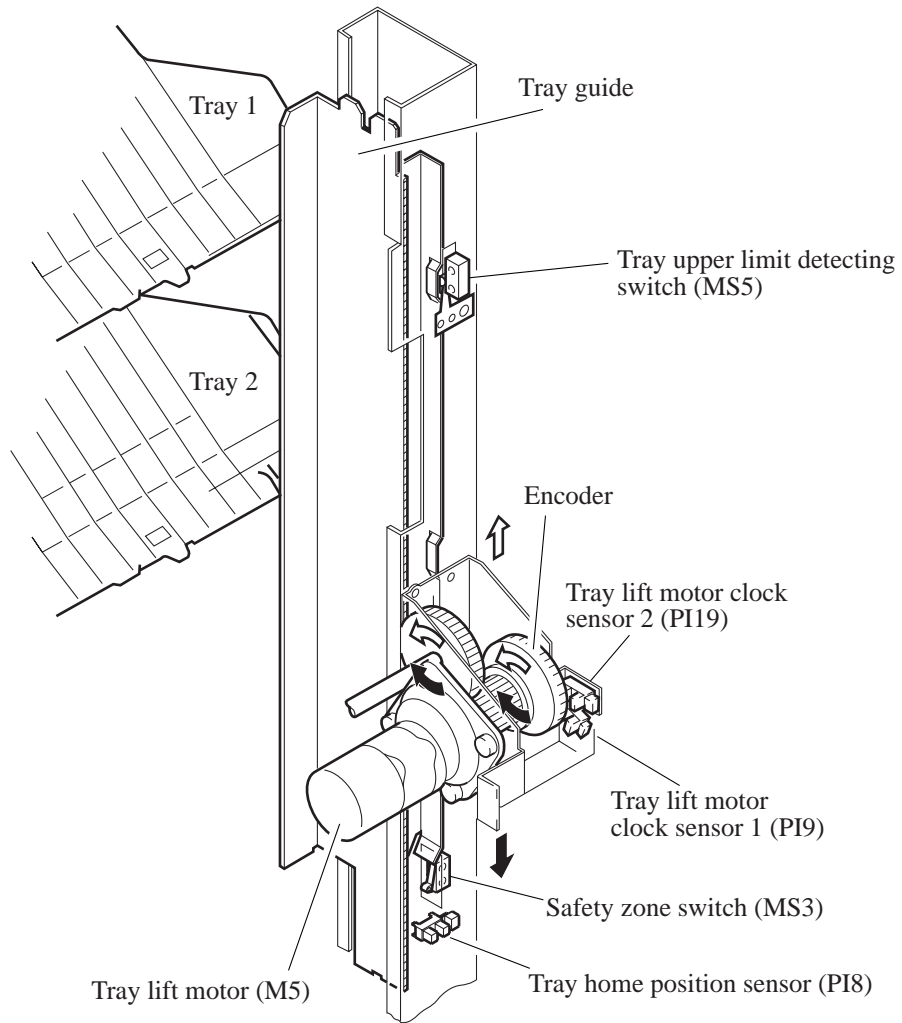

Figure 2-239

H. Detecting the Height of Stack on the Tray

1. Outline

The number of sheets delivered to the tray and the number of sets (number of stapling operations) are stored in memory by the finisher controller PCB. The height of the stack is checked by the height sensor (PS1). See Table 2-201 for the maximum loading capacity of each tray.

The finisher controller PCB stops its operation when the conditions in Table 2-201 occur, informing the host machine that the tray is full.

Stacking mode		Non-staple sort			Staple sort		
		Small-size	Large-size	Mixed sizes	Small-size	Large-size	Mixed sizes
Tray 1	80 g/m ²	147 mm high (1000 sheets)	74 mm high (500 sheets)	74 mm high (500 sheets)	110 mm high (750 sheets/ 50 sets)	74 mm high (500 sheets/ 50 sets)	74 mm high (500 sheets/ 50 sets)
	90 g/m ²	147 mm high (850 sheets)	74 mm high (400 sheets)	74 mm high (400 sheets)	110 mm high (600 sheets/ 30 sets)	74 mm high (400 sheets/ 30 sets)	74 mm high (400 sheets/ 30 sets)
	105 g/m ²	147 mm high (750 sheets)	74 mm high (350 sheets)	74 mm high (350 sheets)	110 mm high (550 sheets/ 30 sets)	74 mm high (350 sheets/ 30 sets)	74 mm high (350 sheets/ 30 sets)
Tray 2	80 g/m ²	147 mm high (1000 sheets)	74 mm high (500 sheets)	74 mm high (500 sheets)	110 mm high (750 sheets/ 50 sets)	74 mm high (500 sheets/ 50 sets)	74 mm high (500 sheets/ 50 sets)
	90 g/m ²	147 mm high (850 sheets)	74 mm high (400 sheets)	74 mm high (400 sheets)	110 mm high (600 sheets/ 30 sets)	74 mm high (400 sheets/ 30 sets)	74 mm high (400 sheets/ 30 sets)
	105 g/m ²	147 mm high (750 sheets)	74 mm high (350 sheets)	74 mm high (350 sheets)	110 mm high (550 sheets/ 30 sets)	74 mm high (350 sheets/ 30 sets)	74 mm high (350 sheets/ 30 sets)

- Notes: 1. The capacity for the non-staple sort mode is approximate and computed based on 80 g/m² paper.
 2. Alignment for stacks containing of 750 sheets or more is not guaranteed.
 3. Stacking height precision is ±7 mm.

Table 2-201

Note:

1. The term “small-size” stands for A4, A5-R, B5, LT, ST-R.
2. The term “large-size” stands for A3, B4, A4-R, B5-R, LD, LG, LT-R, FOLIO, COMPUTER.

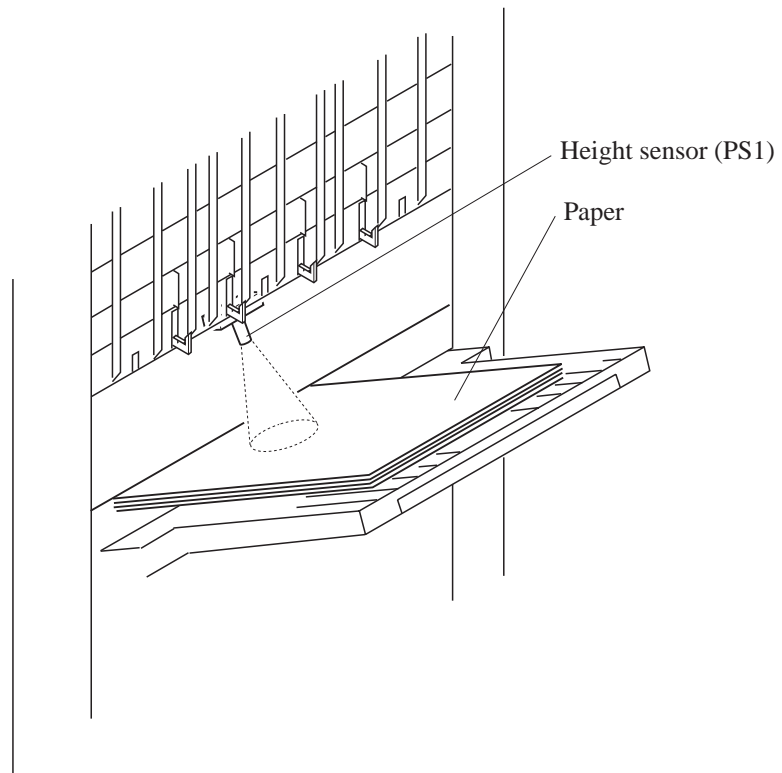

Figure 2-240

I. Shutter Operation

Before the tray on which sheets are output is shifted by the tray lift motor (M5) to another tray, the finisher controller PCB closes the shutter mounted on the delivery slot before moving the tray, protecting the existing stack on the tray from the delivery slot and intrusion of hands.

The shutter moves up (to close) when the second feed motor (M8) rotates counterclockwise, and is held in position when the motor stops. When the second feed motor rotates counterclockwise once again, it moves down (to open) to enable delivery.

When the shutter is held at the up position, claws slide out of the swing guide to engage the back of the shutter. This way, the existing slack and the swing guide engage while the tray is moved, preventing the guide from opening. The claws slide in when the shutter is moved down to release the engagement.

The upward movement of the shutter is monitored by the shutter closed detecting switch (MS4), and the downward movement is monitored by the shutter open sensor (PI5).

See the following diagrams for how these operations take place.

- 1) The second feed motor rotates counterclockwise to move the shutter up.

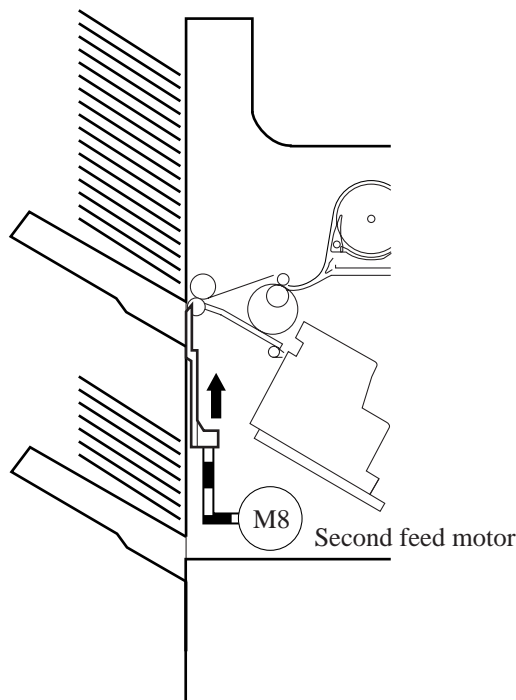

Figure 2-241

- 2) The tray lift motor rotates and the new tray moves to the stacking lower limit. The distance of movement is detected by the tray lift motor clock sensor 1/2 (PI9/PI19).

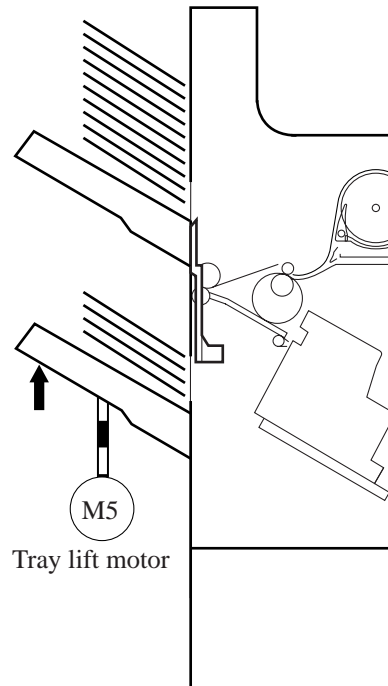

Figure 2-242

- 3) The second feed motor rotates counterclockwise and the shutter moves down.

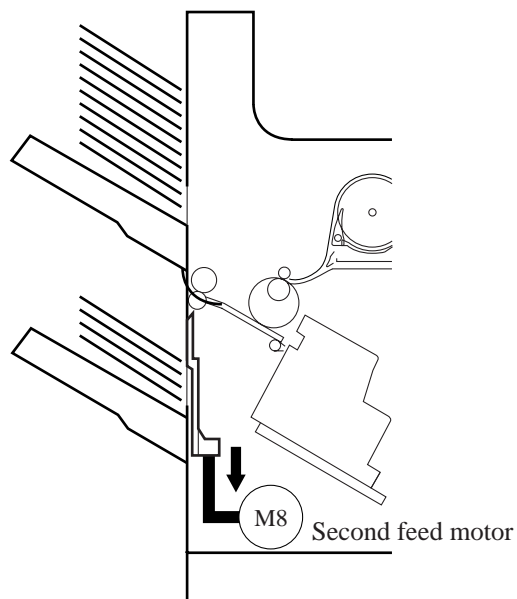

Figure 2-243

- 4) The tray lift motor rotates and the tray moves to suit the height of the stack. The appropriate height in relation to the existing stack is checked by the height sensor (PS1).

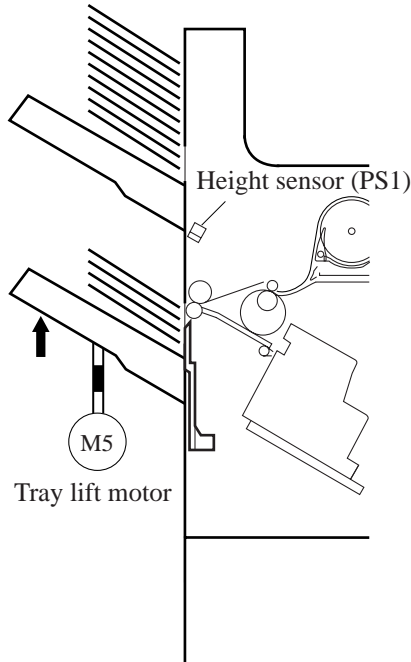

Figure 2-244

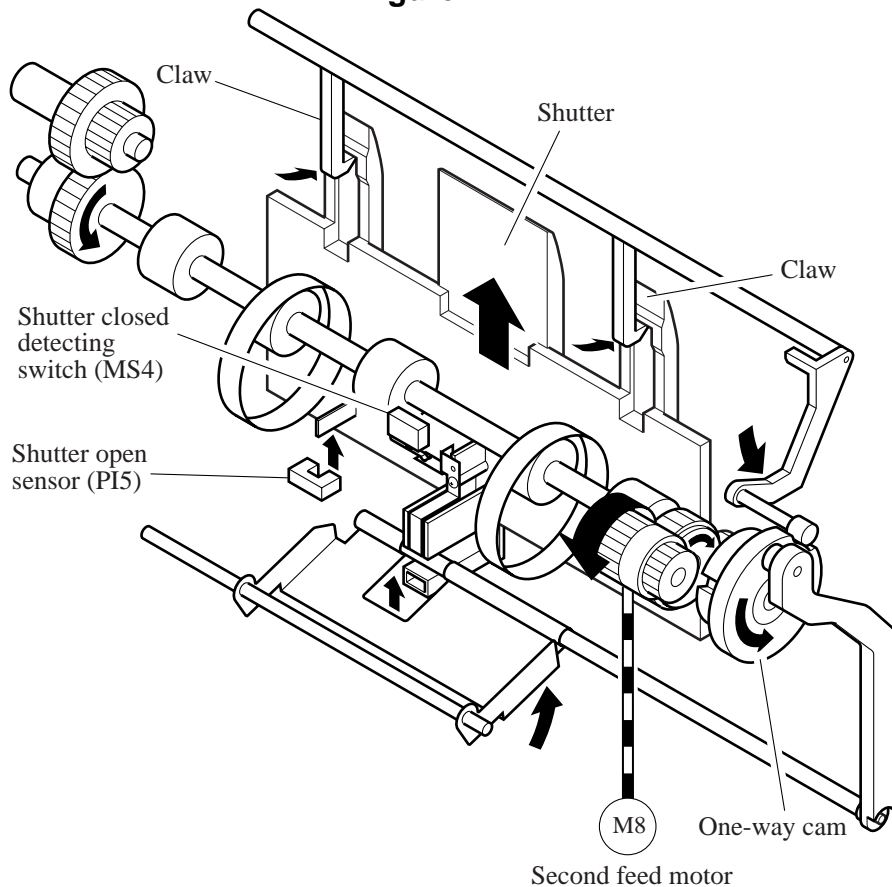

Figure 2-245

Sequence Operations (shutter drive)
Move from Tray 1 to Tray 2

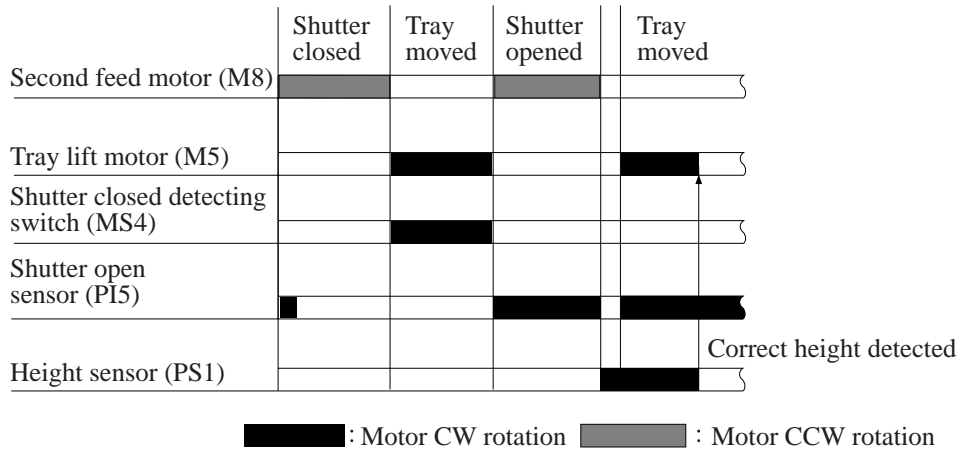

Figure 2-246

J. Buffer Path Operation

1. Outline

This machine is provided with a buffer paper path for continuously receiving paper from the host machine during stapling and job offset operation on the stapling tray. A maximum of three copies (three originals or more in the stapling mode) are wrapped around the buffer roller. During this time, job offset and stapling are performed on the stapling tray.

The following shows operation on the buffer paper path.

- 1) When the first sheet arrives, the buffer inlet solenoid (SL2) remains off. The first sheet enters the buffer path.

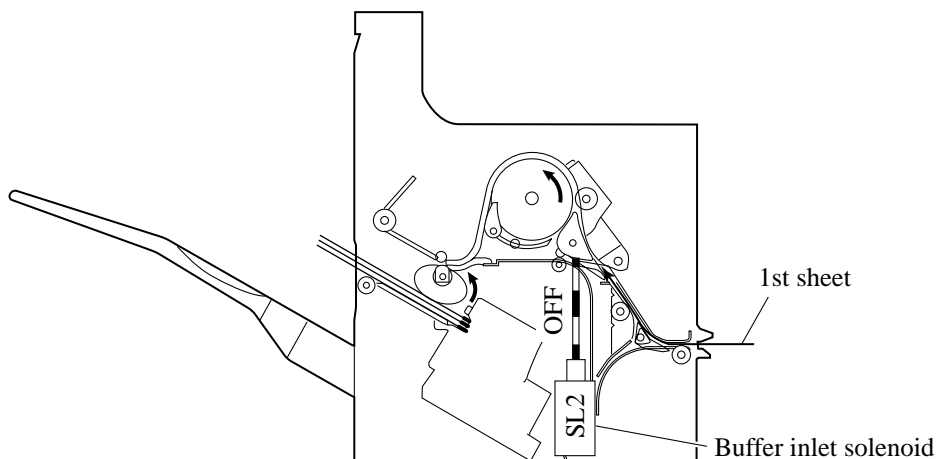

Figure 2-247

- 2) When the leading edge of the sheet has moved past the buffer path inlet paper sensor (PI17), the buffer outlet solenoid (SL3) is turned on so as to cause the sheet to wrap around the buffer roller.

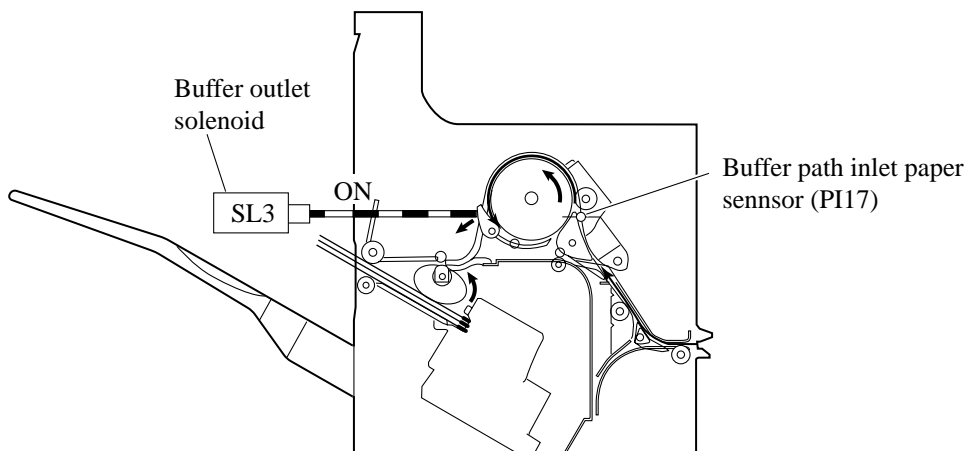

Figure 2-248

- 3) When the leading edge of the sheet has moved past the buffer path paper sensor (PI14), the buffer roller stops and waits for the second sheet.

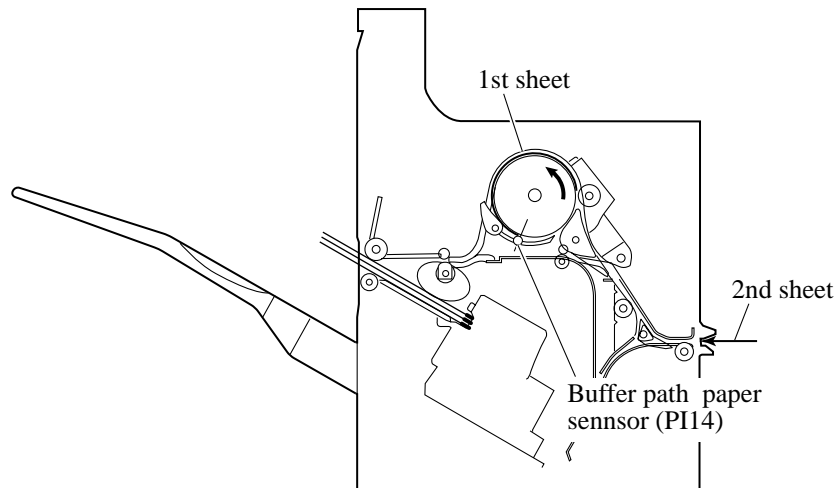

Figure 2-249

- 4) When the second sheet arrives and its leading edge reaches the inlet sensor (PI1), the buffer roller starts to operate once again.

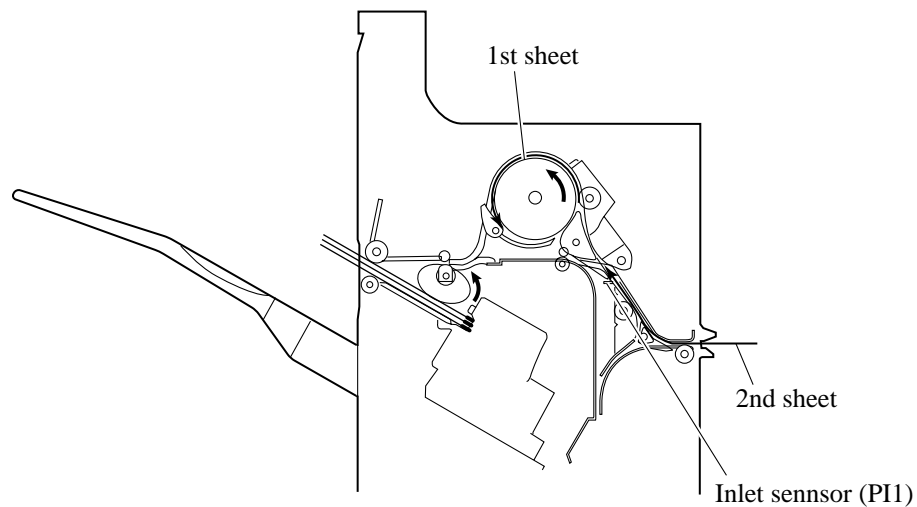

Figure 2-250

- 5) The buffer roller continues to rotate, and the second sheet overlaps the first sheet.

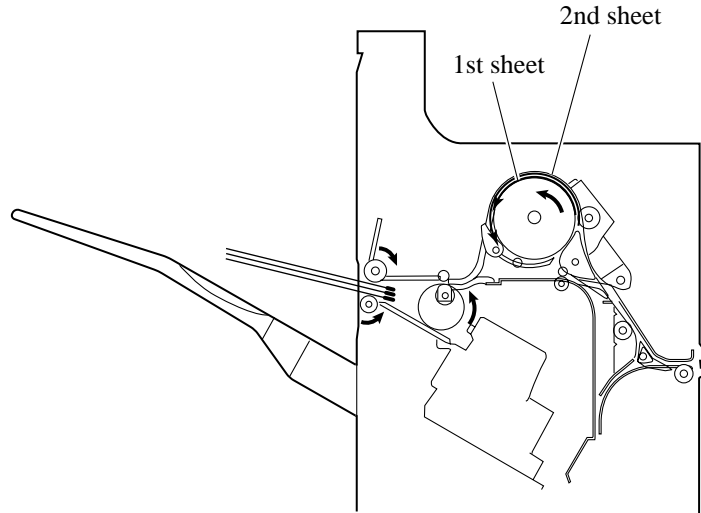

Figure 2-251

- 6) When the trailing edge of the second sheet has moved past the buffer path paper sensor (PI14), the buffer roller stops and waits for the third sheet.

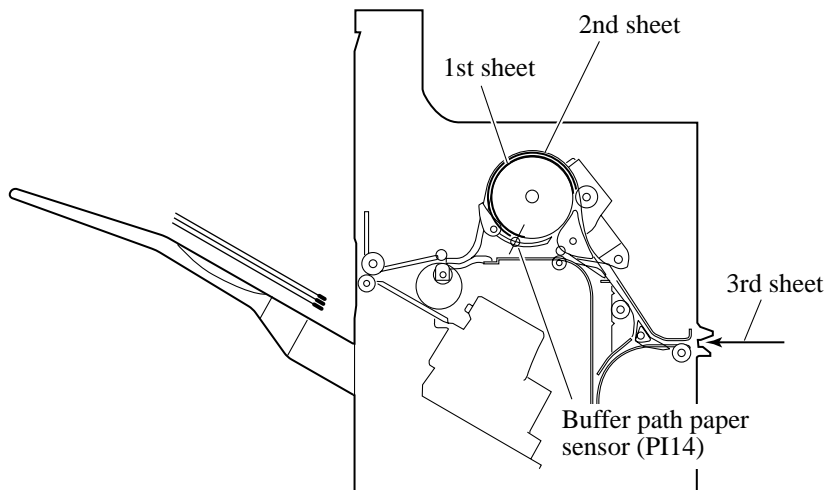

Figure 2-252

- 7) When the third sheet arrives and its leading edge reaches the inlet sensor (PI1), the buffer roller starts to operate once again.

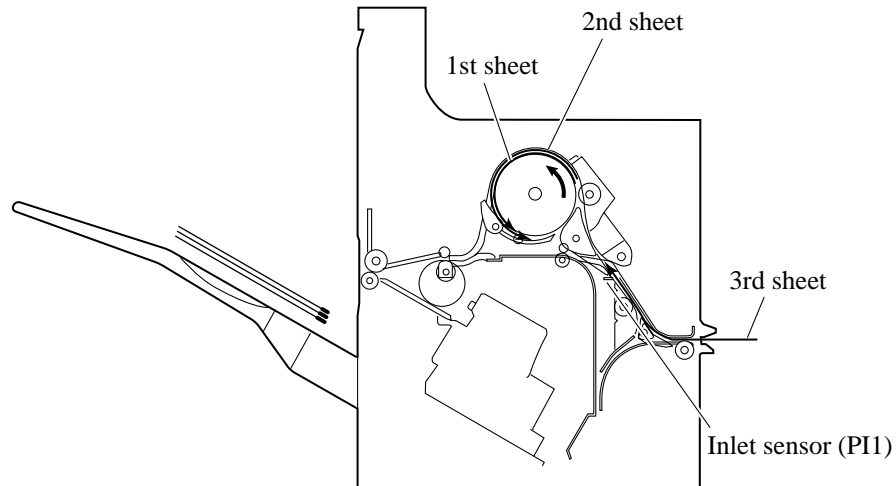

Figure 2-253

- 8) When the leading edge of the third sheet reaches the inlet sensor (PI1), the buffer outlet solenoid (SL3) goes off so that the path is directed in the direction of delivery. (The actual switch-over will occur after the trailing edge of the first sheet has moved past the flapper.)

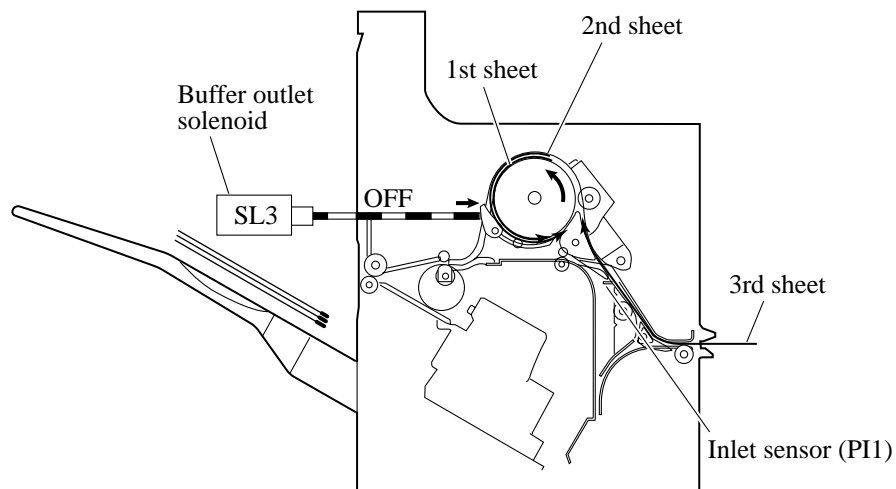

Figure 2-254

- 9) The buffer roller continues to rotate, the third sheet overlaps the first and second sheets, and the three sheets are fed together towards the delivery roller.

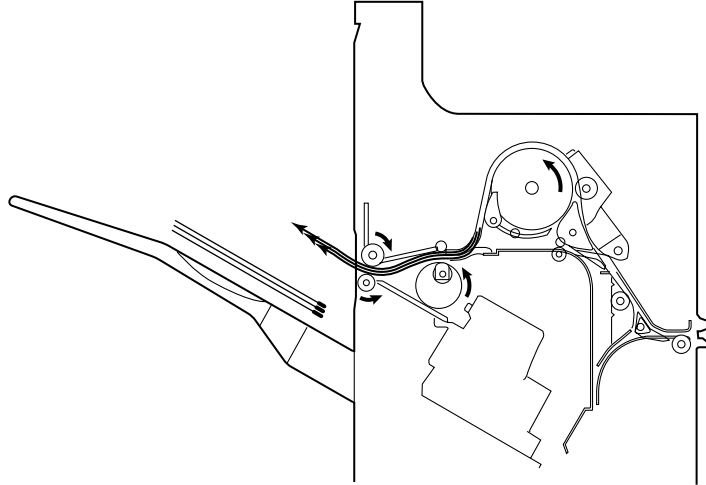

Figure 2-255

K. Detecting Jams

The following sensors are used to detect the presence/absence of paper and to make sure that sheets are moved properly:

- Inlet sensor (PI1)
- Delivery sensor (PI3)
- Stapling tray sensor (PI4)
- Buffer path paper sensor (PI14)

A jam is identified with reference to the presence/absence of paper at each specific sensor at the times programmed in the memory of the microprocessor (CPU) on the finisher controller PCB.

When the CPU identifies a jam, it suspends the finisher's delivery operation and informs the host machine DC controller of the presence of the jam.

The tray 1 paper sensor (PI11) and tray 2 paper sensor (PI12) are not used to detect jams.

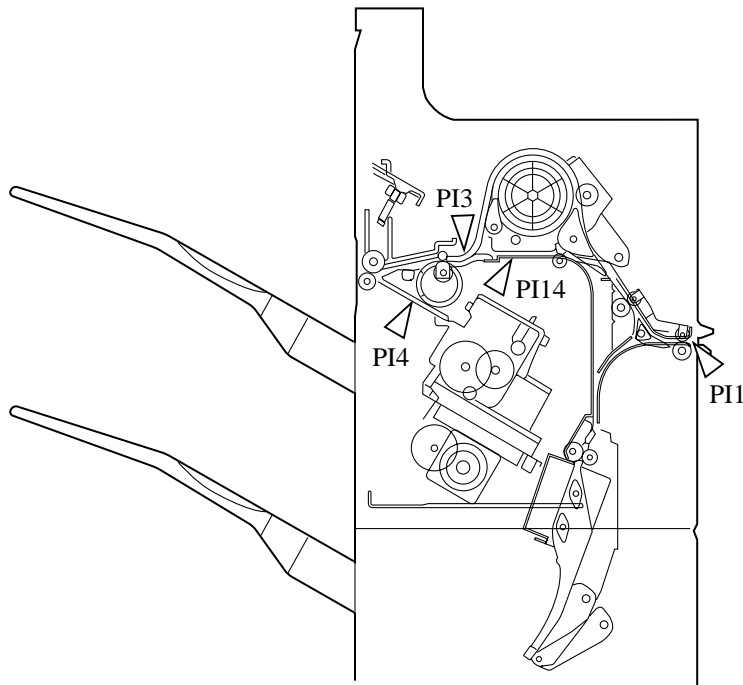

Figure 2-256

No.	Sensor names
PI1	Inlet sensor
PI3	Delivery sensor
PI4	Stapler tray sensor
PI14	Buffer path paper sensor

Table 2-202

1. Inlet Sensor Delay Jam

The inlet sensor does not detect paper when feeding an equivalent of 400 mm from when the host machine delivery signal has been issued.

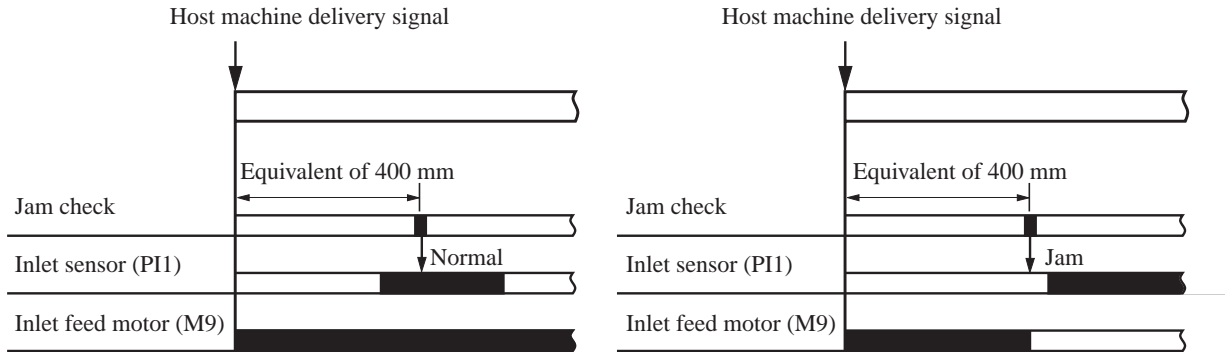

Figure 2-257

2. Inlet Sensor Stationary Jam

The sheet does not move past the inlet sensor when an equivalent of twice the feeding length of the sheet has been fed after the sensor has been turned on.

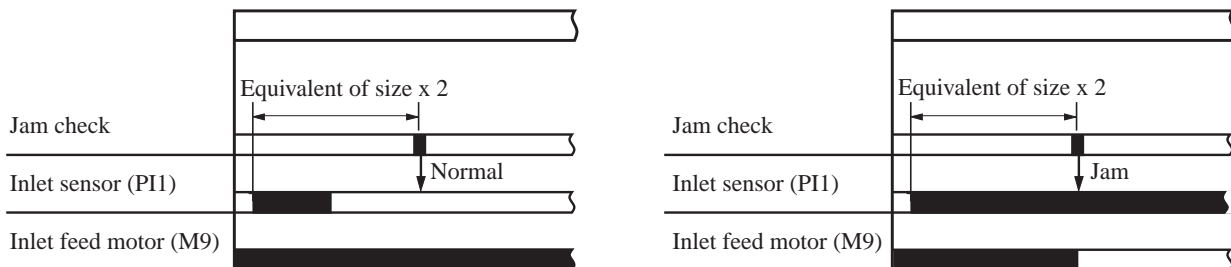

Figure 2-258

3. Buffer Path Paper Sensor Delay Jam

The buffer inlet sensor does not detect paper when an equivalent of 772 mm has been fed after the inlet sensor has been turned on.

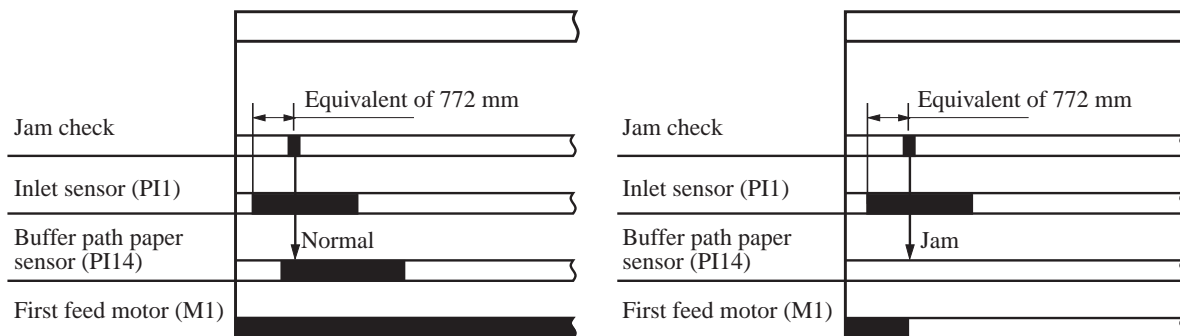

Figure 2-259

4. Buffer Path Paper Sensor Stationary Jam

The sheet does not move past the buffer inlet sensor when an equivalent of twice the feeding length of the sheet has been fed after the sensor has been turned on.

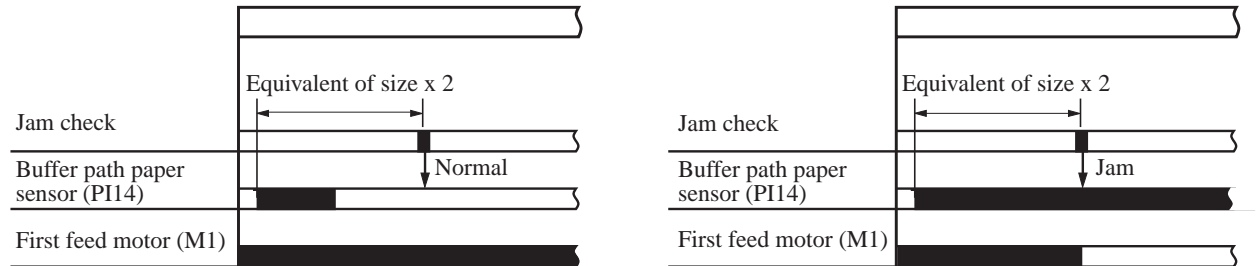

Figure 2-260

5. Delivery Sensor Delay Jam

a. Straight Path

The delivery sensor does not detect paper when an equivalent of 476 mm has been fed after the inlet sensor has been turned on.

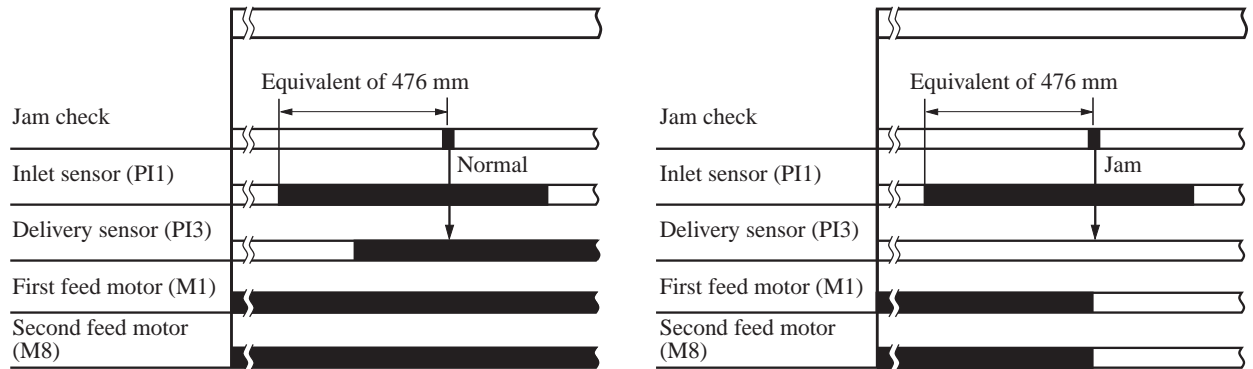

Figure 2-261

b. Buffer Path

The delivery sensor does not detect paper when an equivalent of 550 mm has been fed after the inlet sensor has been turned on.

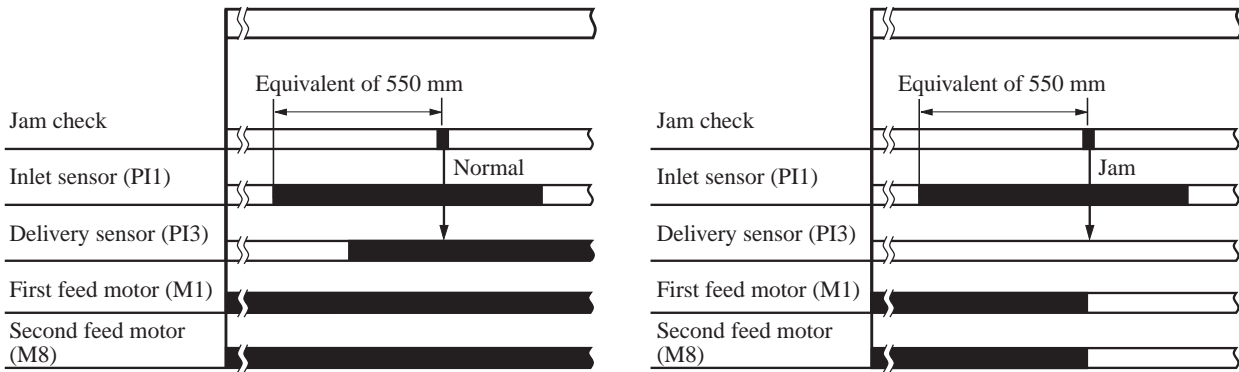

Figure 2-262

6. Delivery Sensor Stationary Jam

The sheet does not move past the delivery sensor when an equivalent of twice the feeding length of the sheet has been fed after the delivery sensor has been turned on.

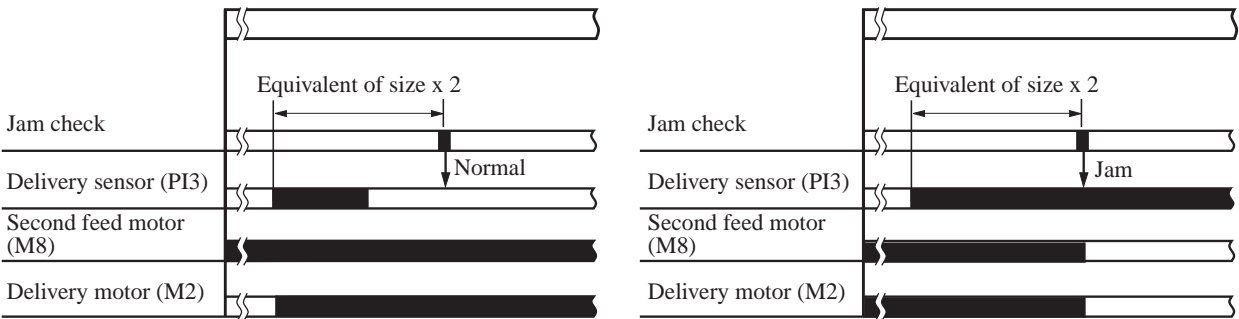

Figure 2-263

7. Stapling Tray Sensor Stationary Jam

The sheet does not move past the stapling tray sensor 1 sec. after the delivery motor (M2) has been turned on.

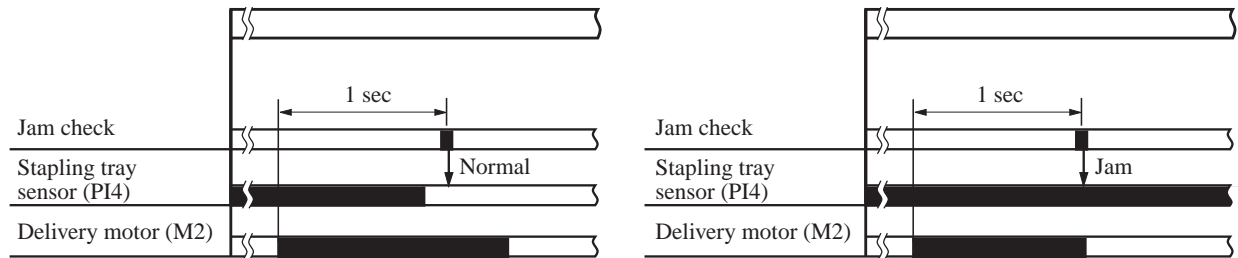

Figure 2-264

III. POWER SUPPLY SYSTEM

1. Outline

The finisher controller PCB is supplied with 24 VDC and 5VDC power when the host machine is turned on, 24VDC is used to drive the motor solenoids. 5VDC is used for sensors and ICs. 24VDC and 5VDC are also used to feed power from the finisher controller PCB to the saddle stitcher controller PCB. Power is also supplied to the punch driver PCB when the optional puncher unit is mounted.

Some of the 24 VDC power used to drive the motors is cut off when the door switch (MS1) is open. The power to the saddle stitcher controller PCB, however, will not be cut off.

Figure 2-301 is a block diagram showing the power supply system.

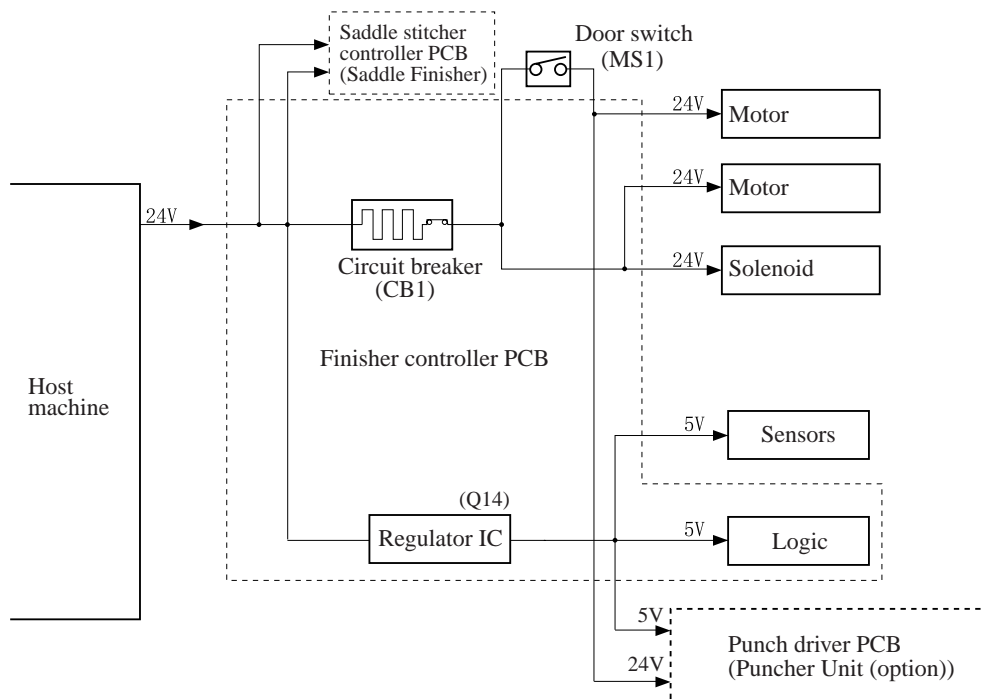

Figure 2-301



2. Protection Functions

The 24 VDC power line used to drive motors and solenoids is equipped with a circuit breaker (CB1) for protection against overcurrent. The 24 V line used to drive the first feed motor (M1), alignment motor (M3), and stapler shift motor (M4) are equipped with a fuse, which is designed to blow when an overcurrent occurs.

CHAPTER 3

SADDLE STITCHER UNIT BASIC OPERATION

1. This chapter discusses the purpose and role of each of the stitcher's functions, and the principles of operation used for the stitcher mechanical and electrical systems. It also explains the timing at which these systems are operated.

The  symbol in drawings indicates transmission of mechanical drive, and signals marked by  together with the signal name indicates the flow of electrical signals.

2. In descriptions of digital circuits on the stitcher, "1" indicates a high signal voltage level, while "0" indicates a low signal voltage level. Voltage values differ according to the circuit.

A microprocessor is used on the stitcher. A description of microprocessor operation is omitted in this chapter as it is practically impossible to check the internal operation of the microprocessor.

Descriptions in this chapter also assume that PCBs will not be repaired at user sites. For this reason, descriptions of circuits on PCBs are limited to block diagrams. Two types of block diagrams are provided for separate functions: diagrams indicating details from sensors up to input sections of major PCBs, and diagrams indicating details from the output sections of major PCBs up the loads.

I. BASIC OPERATION	3-1	C. Controlling the Movement of	
A. Outline	3-1	Sheets	3-21
B. Electrical Circuitry	3-2	D. Aligning the Sheets	3-23
C. Inputs to and Outputs from		E. Controlling the Phase of the	
the Saddle Stitcher Controller		Crescent Roller	3-26
PCB	3-3	IV. STITCHING SYSTEM	3-29
II. FEEDING/DRIVE SYSTEM	3-8	V. FOLDING/DELIVERY	
A. Outline	3-8	SYSTEM	3-32
III. PAPER OUTPUT		VI. CHECKING FOR A JAM	3-40
MECHANISM	3-14	VII. POWER SUPPLY	3-45
A. Outline	3-14		
B. Controlling the Inlet			
Flappers	3-17		

I. BASIC OPERATION

A. Outline

The unit “stitches” (2 points) a stack of sheets delivered by the finisher unit and folds it in two for delivery. All these operations are controlled by the saddle stitcher controller PCB in response to commands from the host machine via the finisher unit.

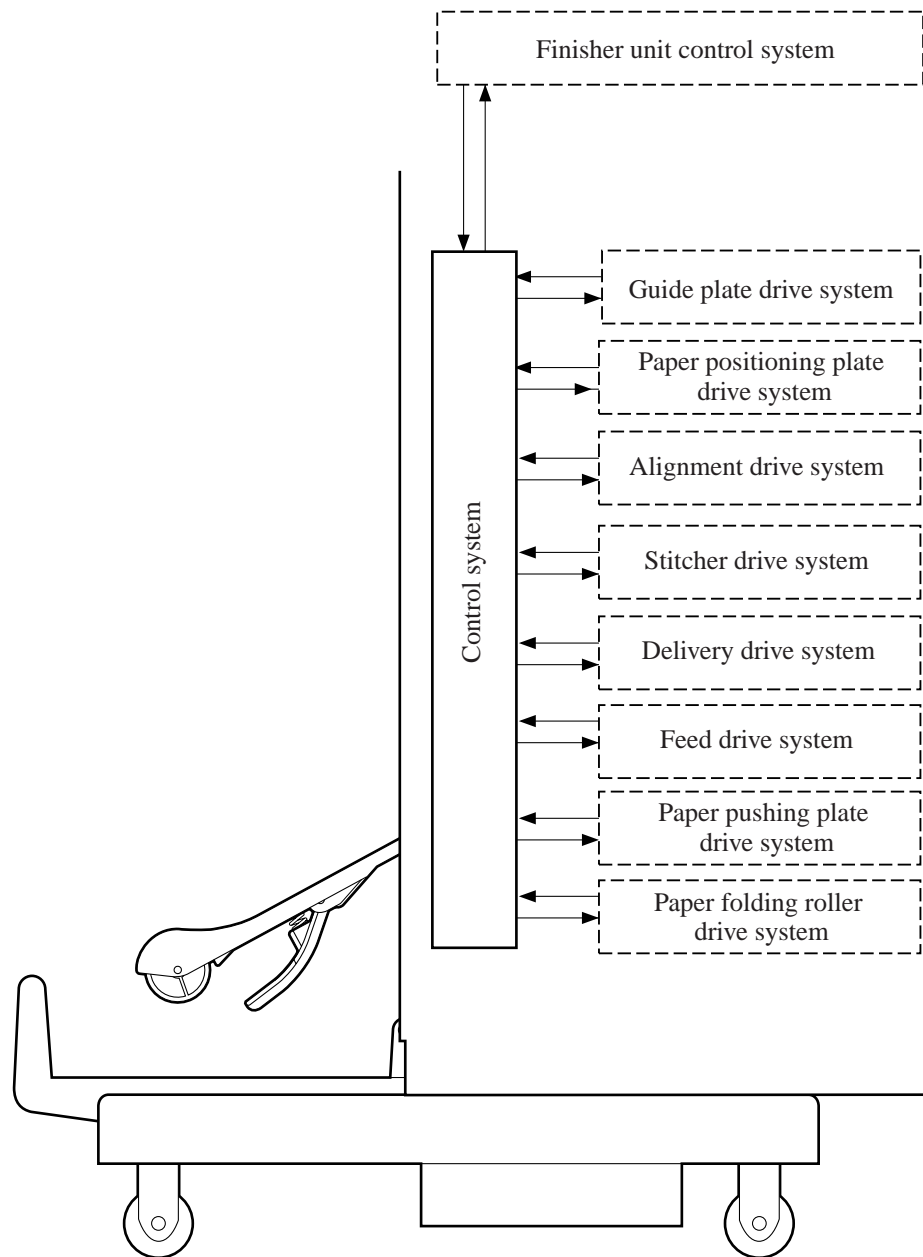

Figure 3-101

B. Electrical Circuitry

The sequence of operations used for the saddle stitcher is controlled by the saddle stitcher controller PCB. The saddle stitcher controller PCB has a microprocessor. This microprocessor is used to control the sequence of operations and to handle serial communications with the finisher controller PCB, driving solenoids and motors in response to the various commands from the finisher controller PCB.

The saddle stitcher controller PCB is also used to communicate the state of various sensors and switches to the finisher controller PCB in serial.

The functions of the major ICs mounted on the saddle stitcher controller PCB are as follows:

- Q1
Controls the sequence of operations.
- Q2
Contains the sequence program.
- Q3
Controls the sequence of operations.
- Q4
Handles IPC communications.

Electrical circuitry block diagram

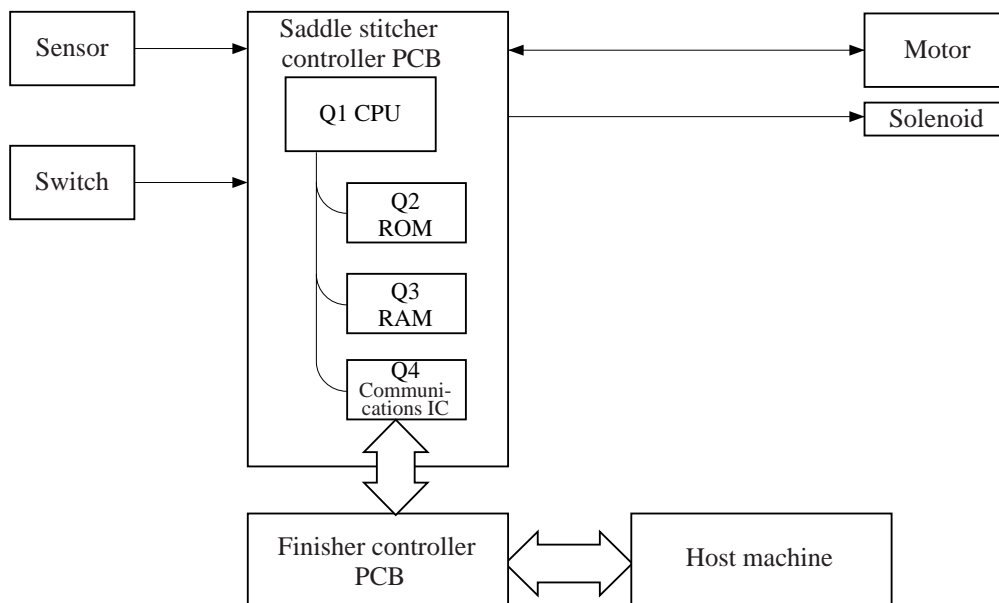

Figure 3-102

C. Inputs to and Outputs from the Saddle Stitcher Controller PCB

1. Inputs to the Saddle Stitcher Controller PCB

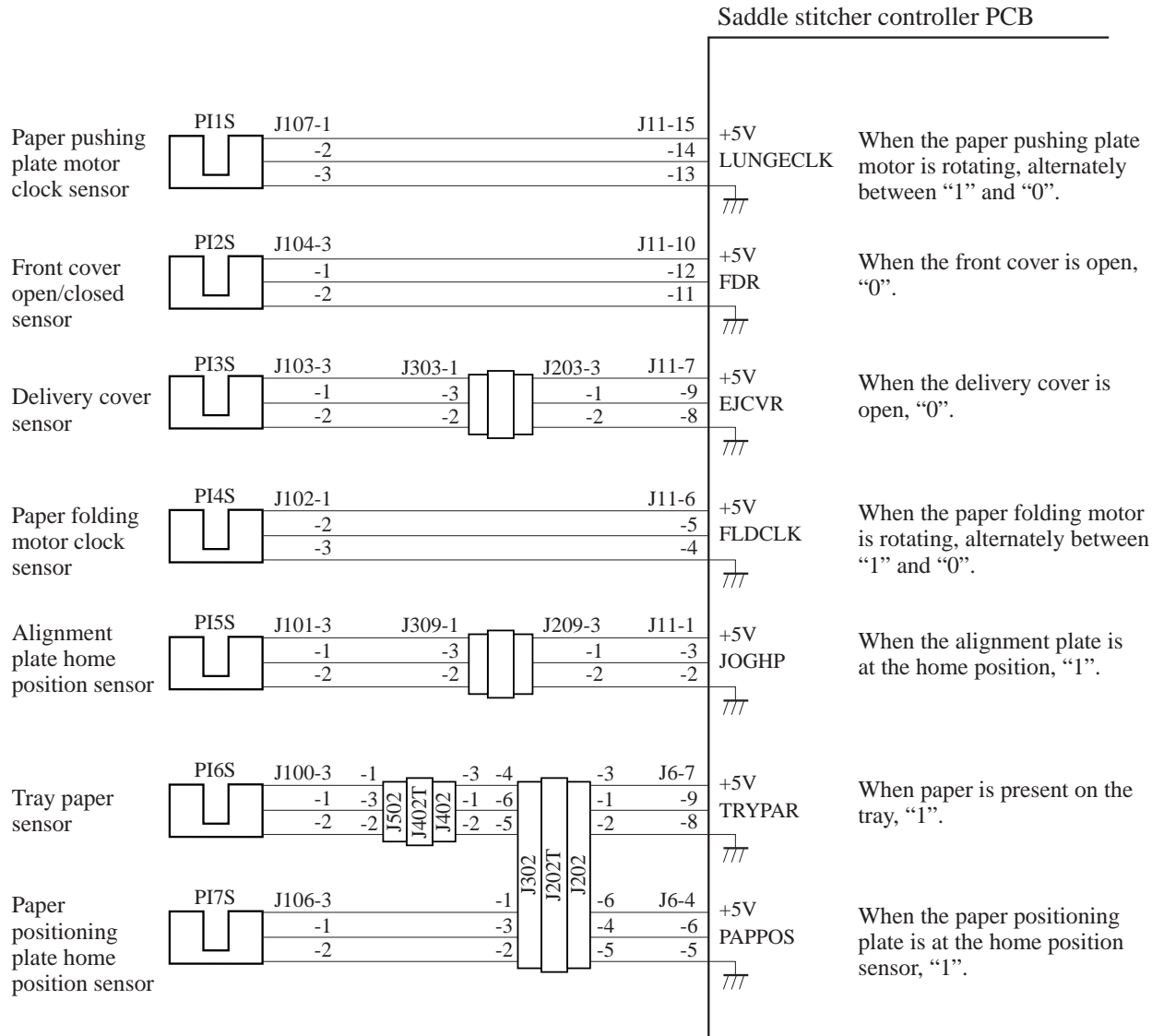

Figure 3-103

2. Inputs to the Saddle Stitcher Controller PCB

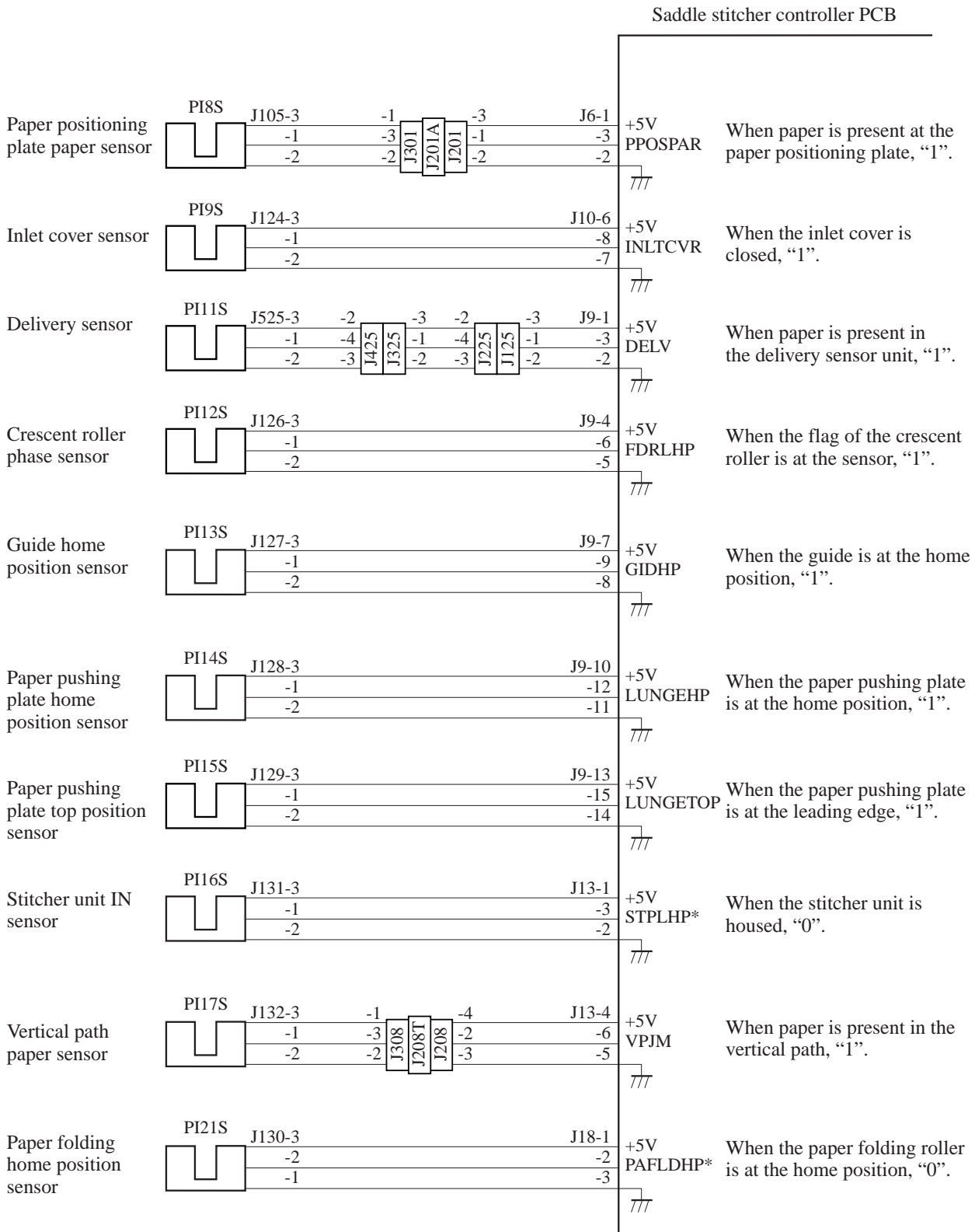

Figure 3-104

3. Inputs to the Saddle Stitcher Controller PCB

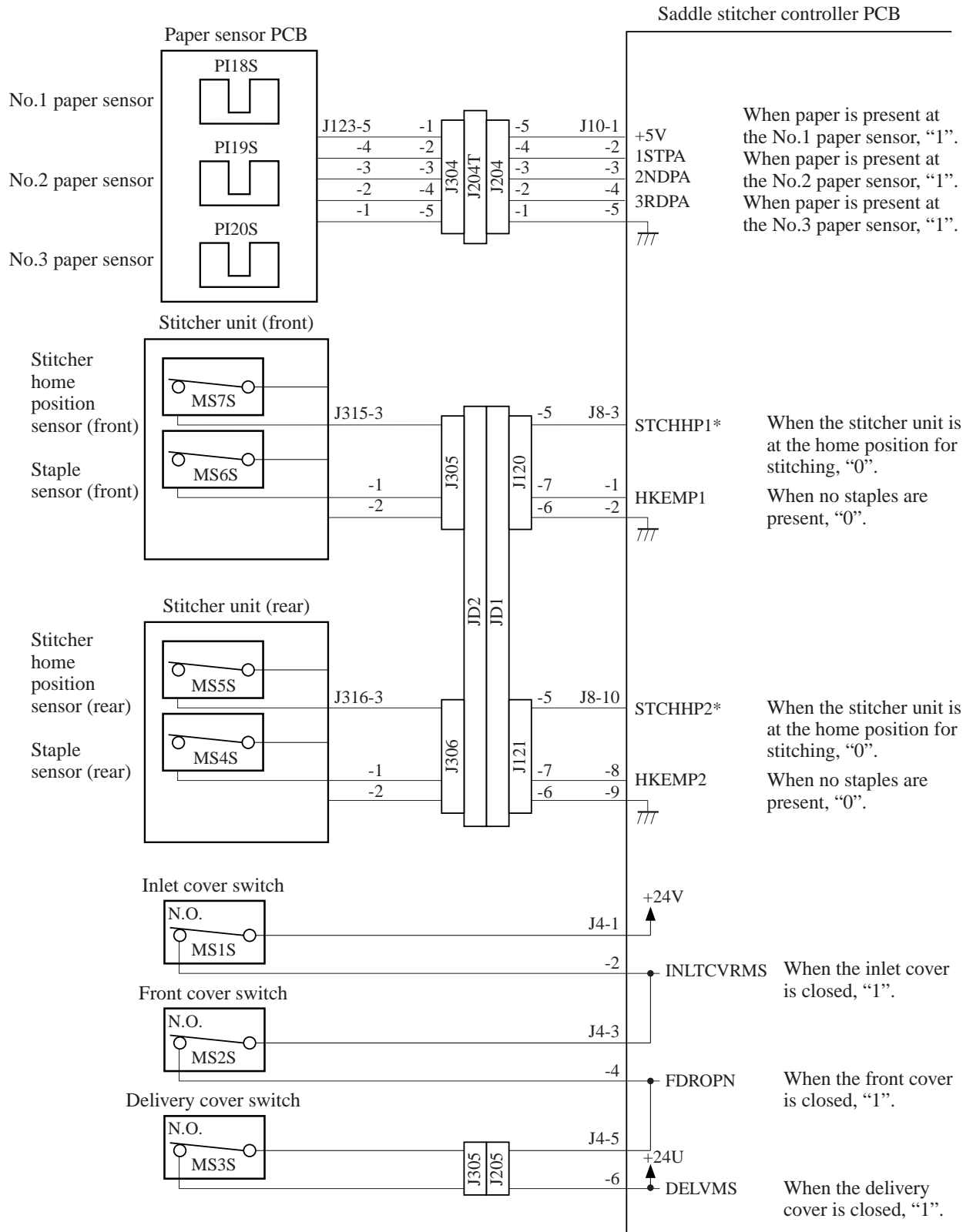

Figure 3-105

4. Outputs from the Saddle Stitcher Controller PCB

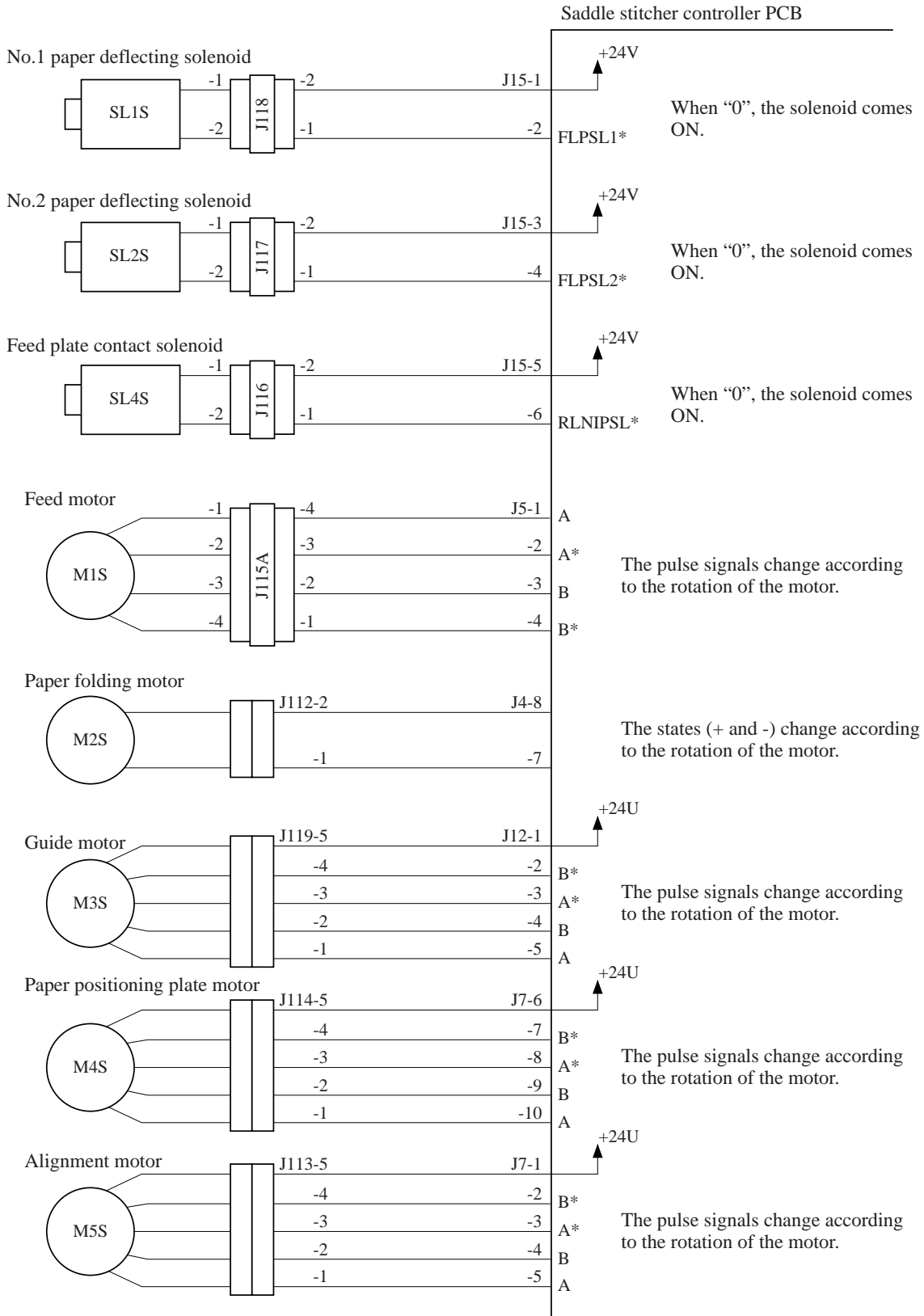

Figure 3-106

5. Outputs from the Saddle Stitcher Controller PCB

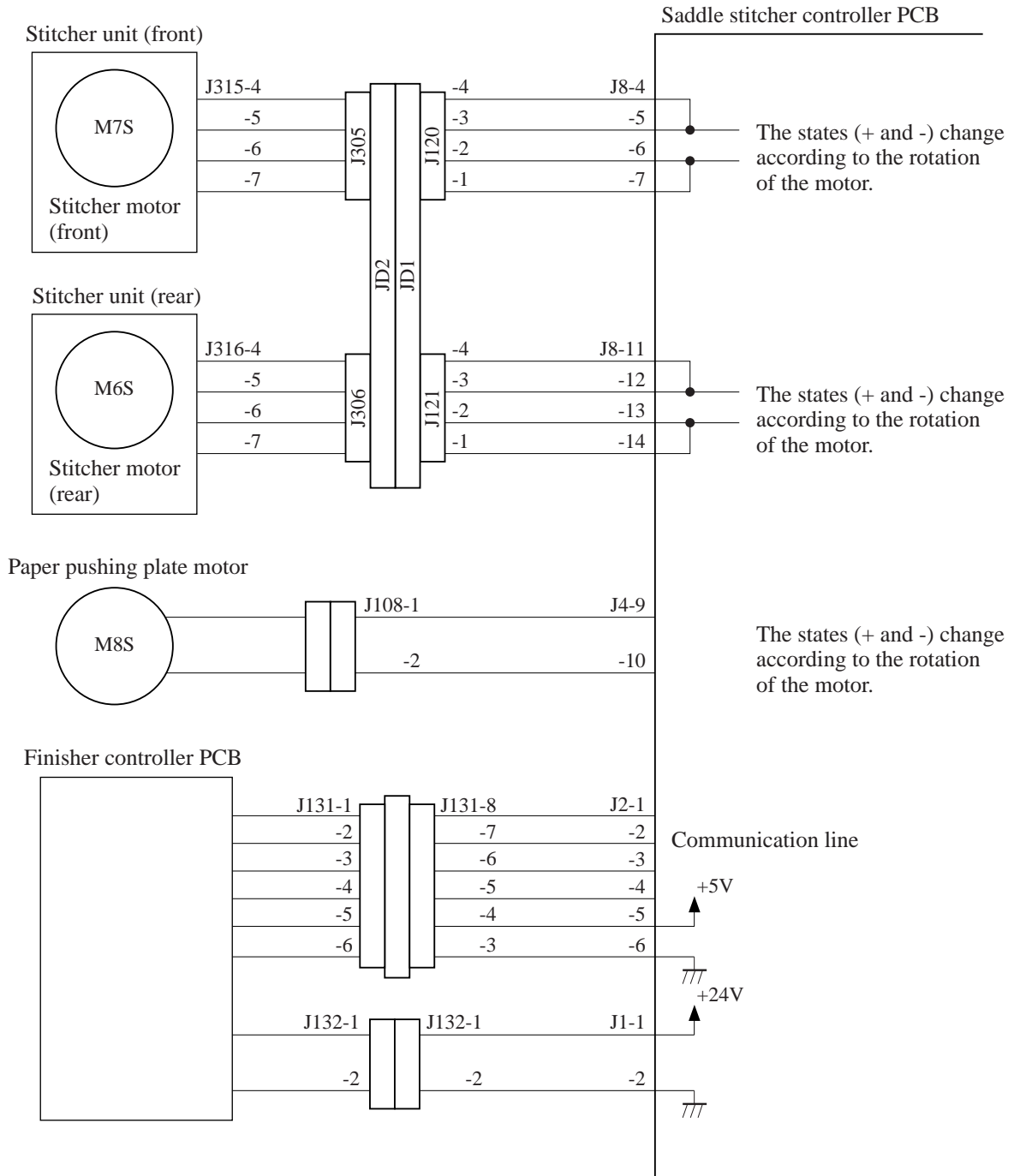

Figure 3-107

II. FEEDING/DRIVE SYSTEM

A. Outline

The stitcher unit aligns the sheets coming from the finisher unit and stitches the resulting stack for delivery to the delivery tray according to the commands coming from the finisher controller PCB.

The machine's operation consists of the following:

1. Receives sheets.
2. Aligns the sheets
3. Stitches the stack.
4. Feeds the stack.
5. Folds and delivers the stack.

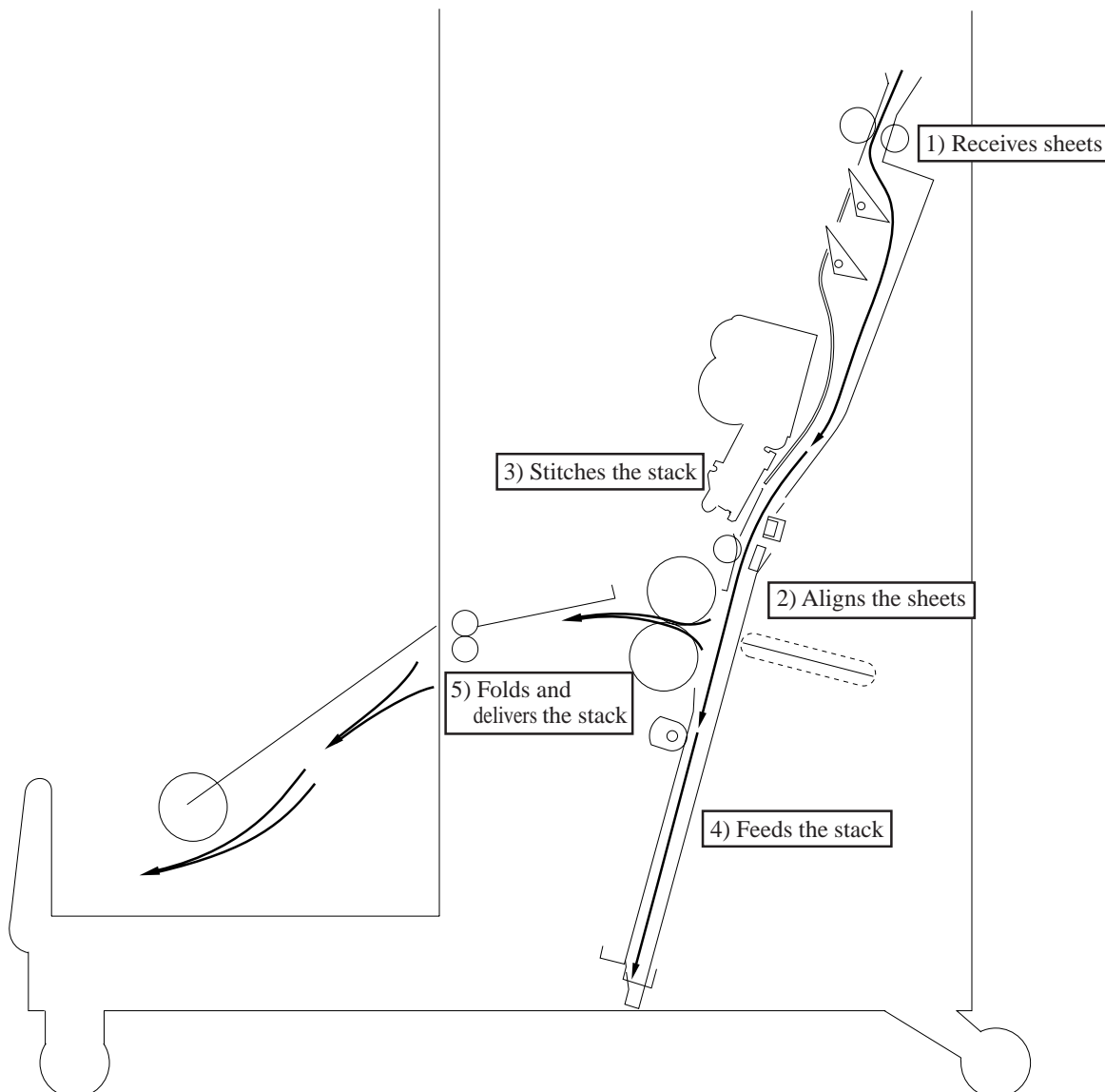

Figure 3-201

1. Receiving Sheets

The stitcher unit receives sheets from the finisher unit and outputs them inside the vertical path in vertical orientation.

The vertical path while sheets are being output is configured by two paper deflecting plates.

The position of the sheets being output is set by the paper positioning plate so that the center of the stack matches the stapling/folding position.

Sheets coming later are output closer to the delivery slot, and the volume of paper that may be output is as follows:

- 15 sheets (maximum of 14 sheets of 80 g/m² + 1 sheet of 200 g/m²)

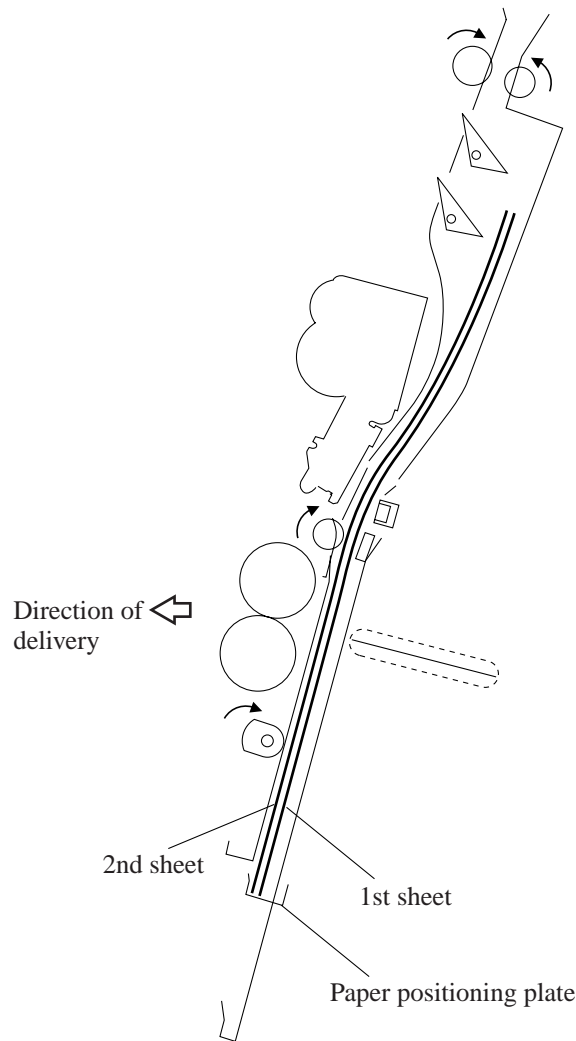

Figure 3-202

2. Aligning the Sheets

The alignment plates operate to put the sheets in order each time a sheet of paper is output to the vertical path assembly. The alignment plates are mounted at the edge of the vertical path assembly.

The alignment plates also operate after stapling to prepare the stack for delivery.

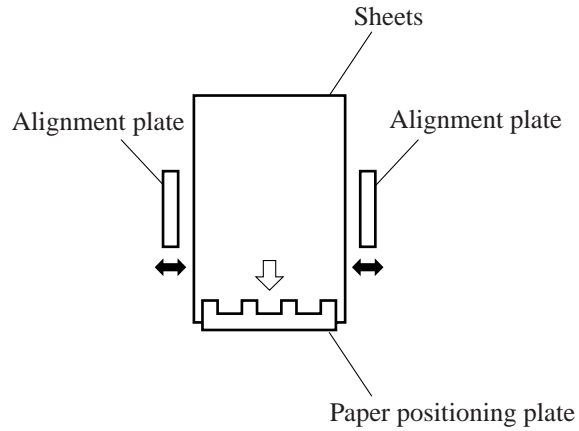

Figure 3-203

3. Stitching

When all sheets have been output, the two stitchers stitch the stack. The stitchers are positioned so that they face the center of a stack.

The two stitchers are not operated simultaneously so as to prevent the paper from wrinkling between two staples and to limit the load on the power supply.

If only one sheet of paper arrives from the host machine, stitching does not take place and the sequence goes to the next operation (stack feeding).

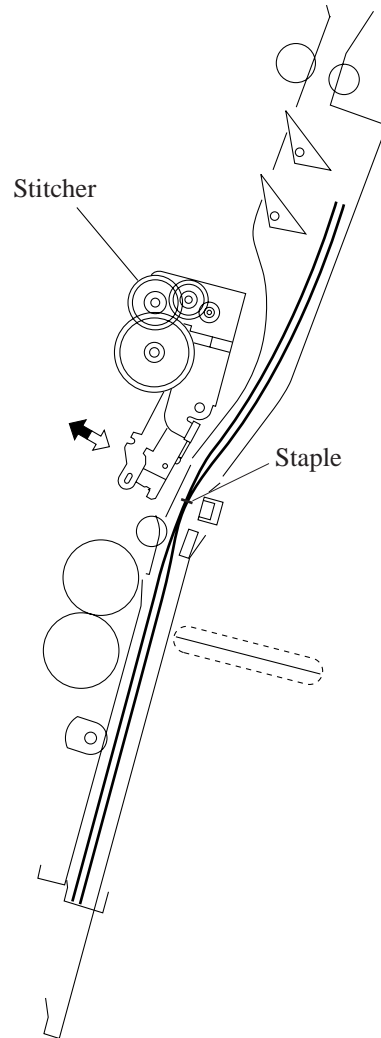

Figure 3-204

4. Feeding the Stack

The unit folds the stitched stack of sheets, and then feeds it to the point of delivery. This point is where the center of the stack, i.e., stapling position, matches the height of the paper pushing plate and the paper folding roller nip.

The stack is moved forward by operating the paper positioning plate. When the plate is operated, the guide plate which has been covering the paper folding rollers, also moves down so that the paper folding rollers directly face the stack.

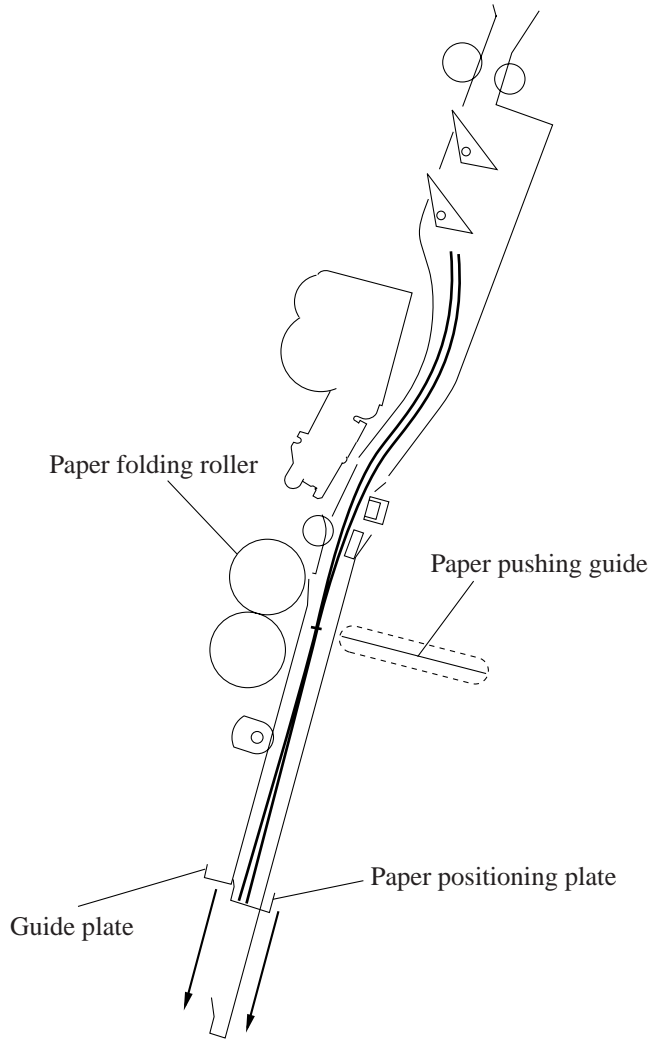

Figure 3-205

5. Folding/Delivering the Stack

The paper pushing plate pushes against the center of the stack to move it in the direction of the paper folding rollers. In response, the paper folding rollers pick the stack along its center and fold it in two. The paper folding rollers together with the delivery roller then move the stack along to output it on the delivery tray.

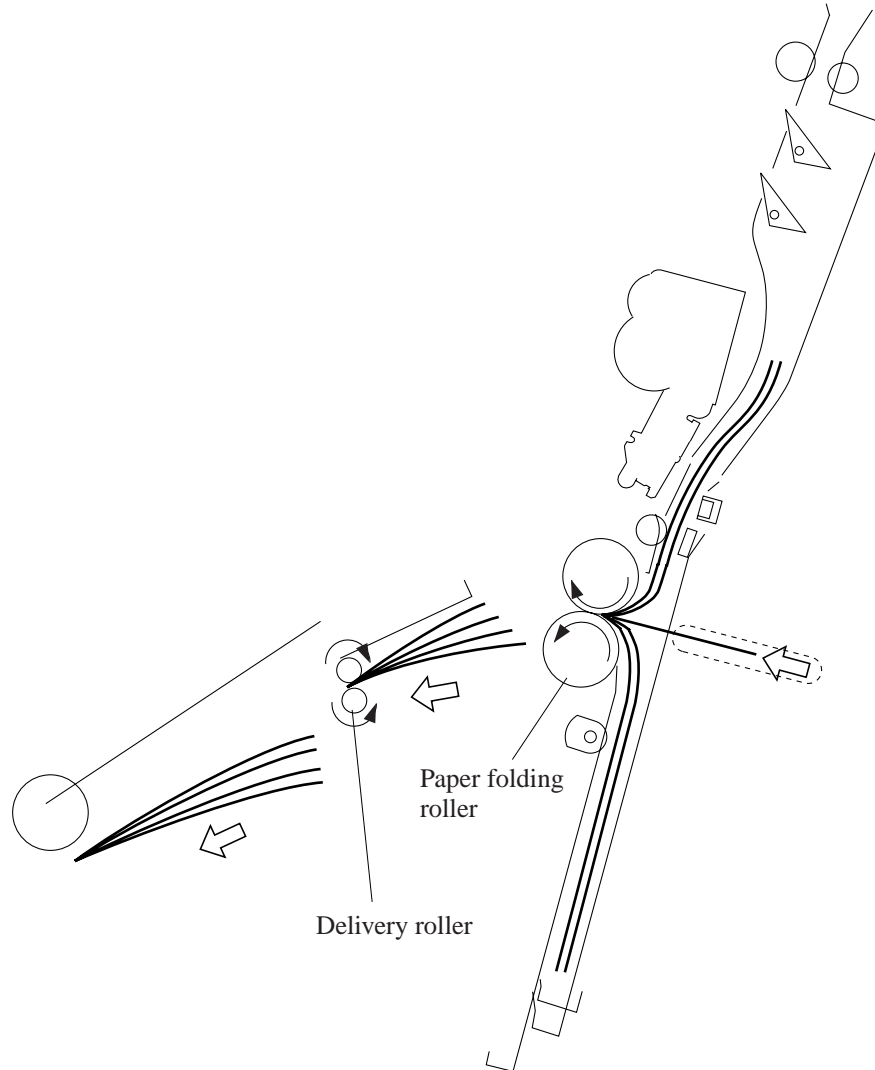

Figure 3-206

III. PAPER OUTPUT MECHANISM

A. Outline

The paper output mechanism serves to keep a stack of sheets coming from the finisher in place for the next steps (stapling, folding).

The paper inlet is equipped with the No.1 flapper and the No.2 flapper, which operate to configure the paper path to suit the size of paper. The paper positioning plate is kept in wait at a predetermined location to suit the size of paper. The paper positioning plate is driven by the paper positioning plate motor (M4S), and the position of the plate is identified in reference to the number of motor pulses coming from the paper positioning plate home position sensor (PI7S). A sheet moved by the inlet roller is handled by the feed rollers and the crescent roller and held in a predetermined position. The feed plate serve to move sheets by coming into contact with or moving away from sheets as needed.

The alignment plates put the stack into order each time a sheet is output. The alignment plates are driven by the alignment motor (M5S), whose position is identified in reference to the number of motor pulses coming from the alignment plate home position sensor (PI5S).

To prevent interference between paper and the paper folding rollers when the paper is being output, the folding rollers are designed to be covered by a guide plate. The guide plate moves down before paper is folded so as to expose the paper folding rollers.

The inlet is equipped with the No.1, No.2 and No.3 paper sensors (PI18S, PI19S, PI20S) each suited to a specific paper size, and the paper positioning plate is equipped with a paper positioning plate paper sensor (PI8S).

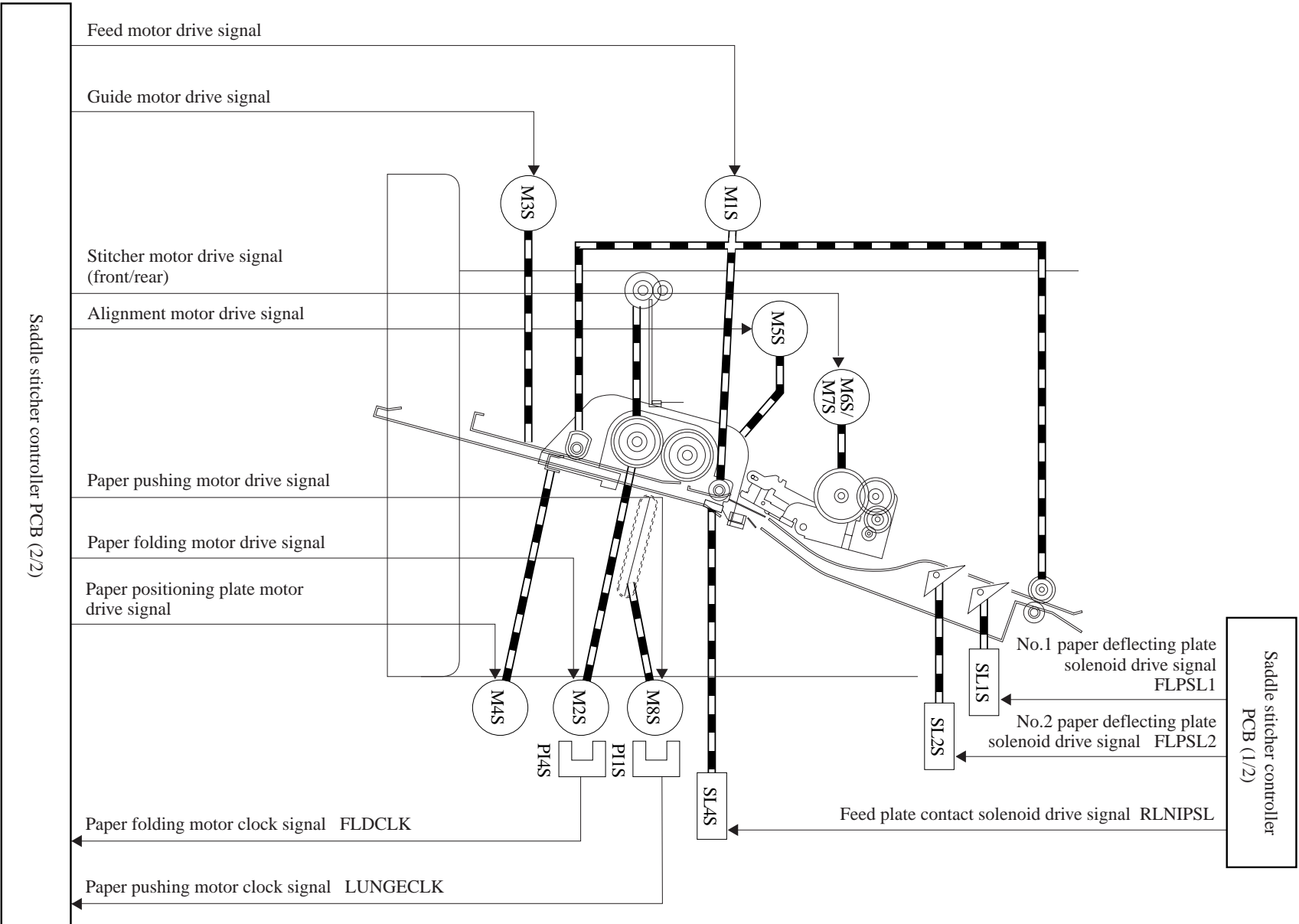

Figure 3-301

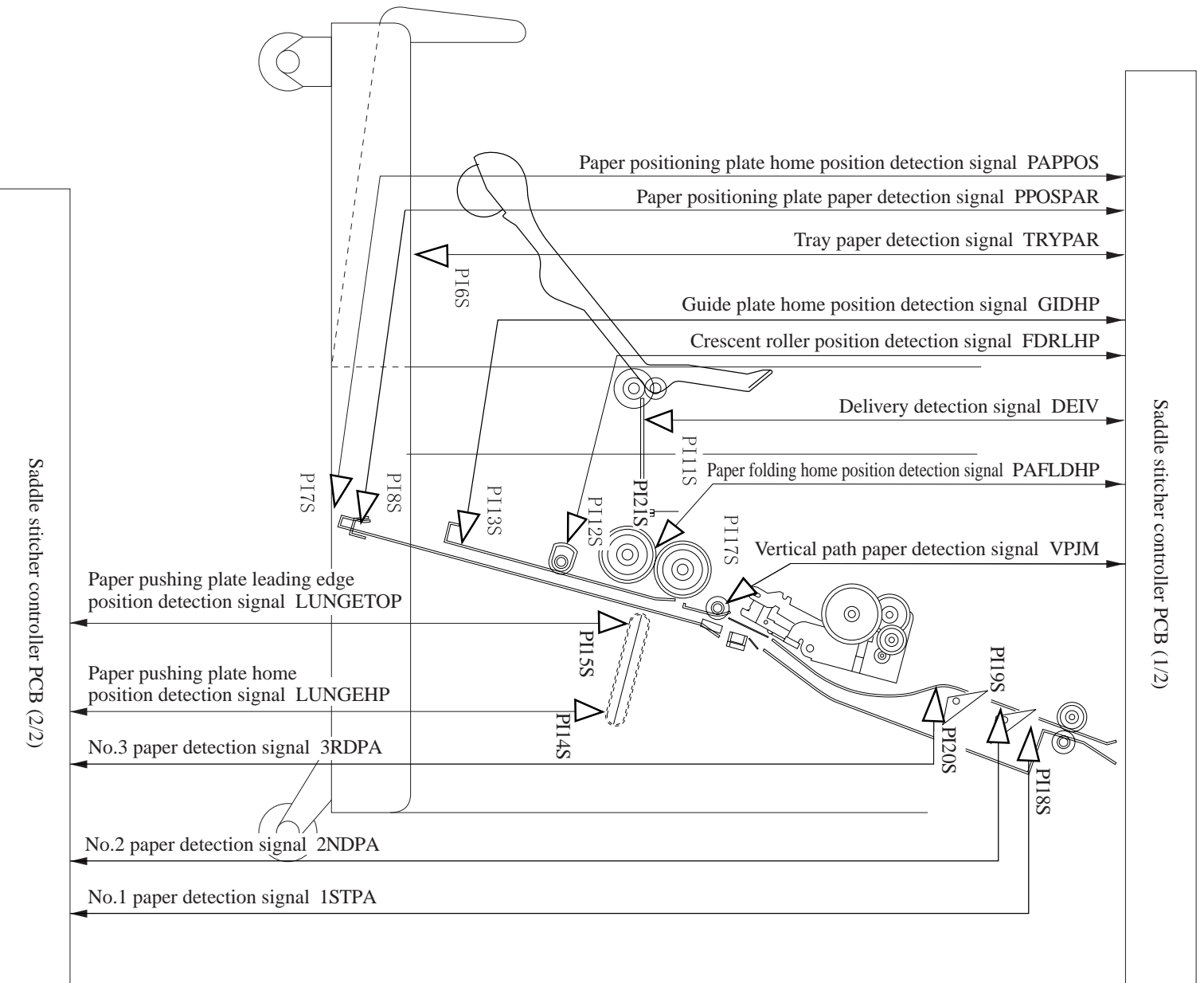

Figure 3-302

B. Controlling the Inlet Flappers

1. Outline

The two flappers mounted at the paper inlet are operated to configure the feed path according to the size of paper. The flappers are used to enable the following:

1. To detect the passage of the trailing edge of the paper being moved by an appropriate sensor.
2. To prevent the following sheet from butting against the top of the existing stack

Table 3-301 shows the relationship between sensors and paper sizes.

Sensor	A3/LD	B4	A4-R/LT-R
No.1 paper sensor (PI18S)	Used	Used	Used
No.2 paper sensor (PI19S)	Not used	Used	Used
No.3 paper sensor (PI20S)	Not used	Not used	Used

Table 3-301

Each flapper is driven by its own solenoid.

Table 3-302 shows the relationship between solenoids and paper sizes.

Solenoid	A3/LD	B4	A4-R/LT-R
No.1 paper deflecting plate solenoid (SL1S)	OFF	ON	ON
No.2 paper deflecting plate solenoid (SL2S)	OFF	OFF	ON

Table 3-302

2. A3/LD Paper Path (3 sheets)

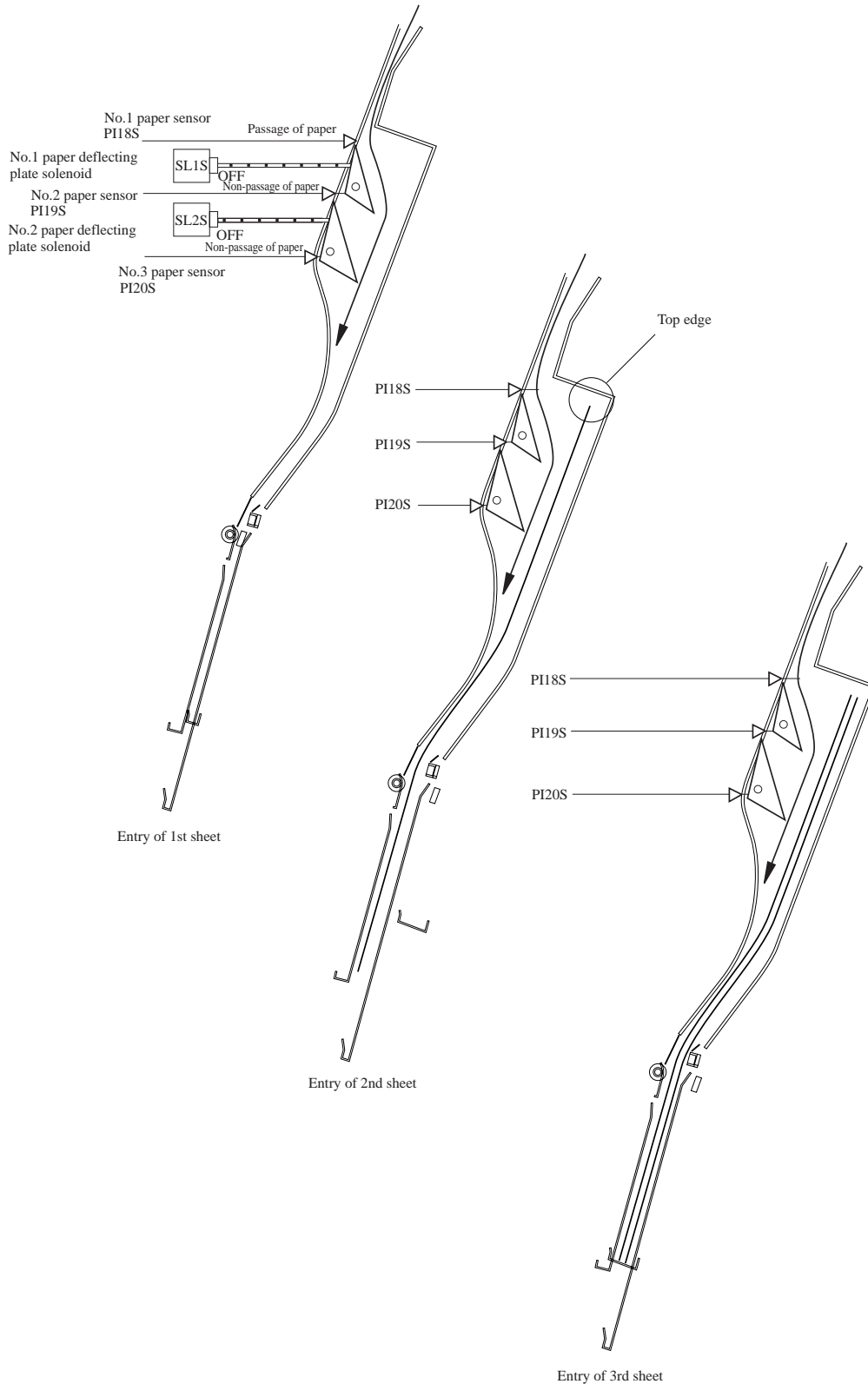

Figure 3-303

3. B4 Paper Path (3 sheets)

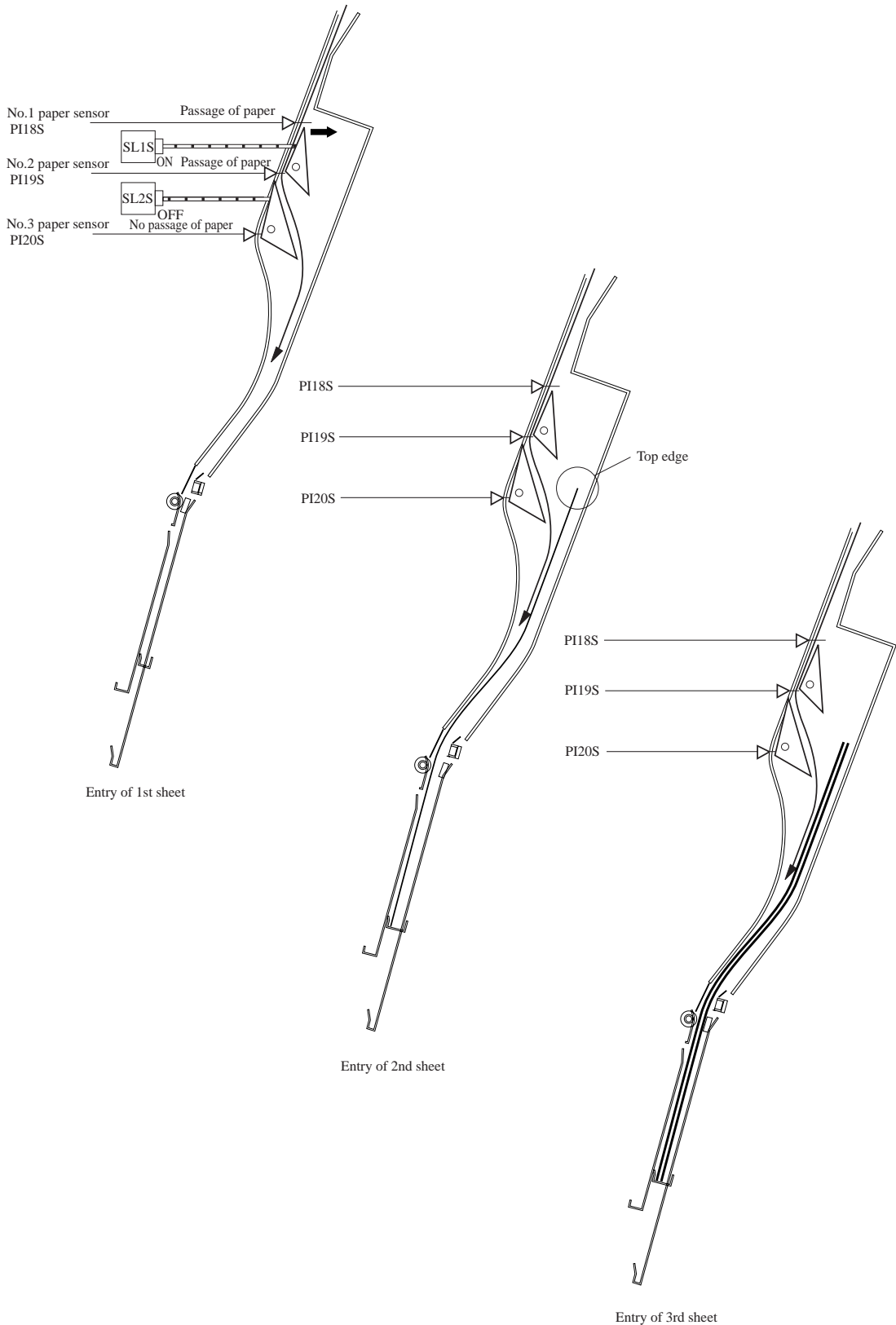

Figure 3-304

4. A4-R/LT-R Paper Path (3 sheets)

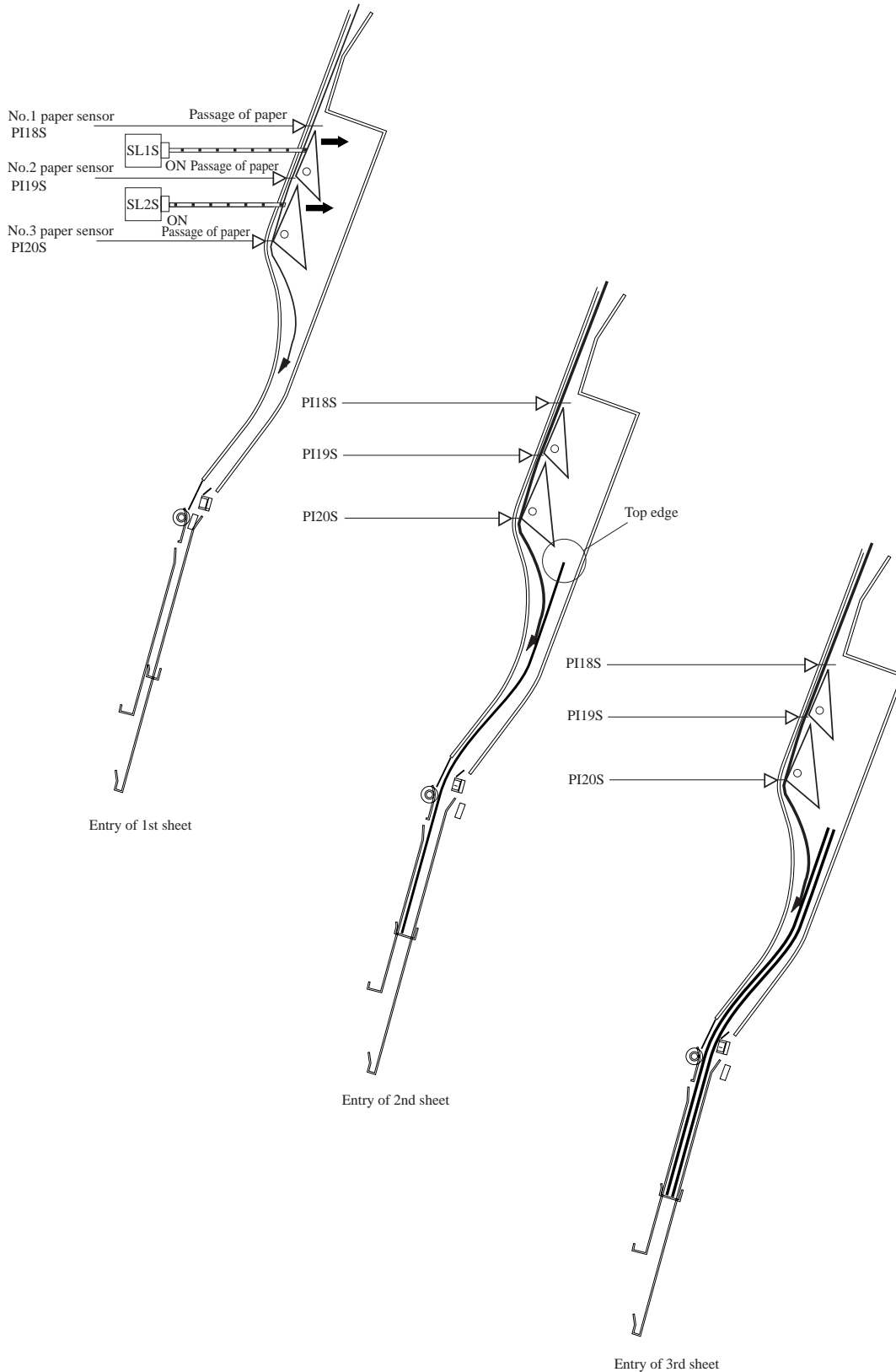

Figure 3-305

C. Controlling the Movement of Sheets

When the leading edge of a sheet has moved past the inlet flapper, the intermediate feed roller and the crescent roller start to move the sheet forward.

The intermediate feed roller is normally not in contact with the path bed. When the leading edge of a sheet reaches the intermediate feed roller contact section, the feed plate contact solenoid (SL4S) causes the roller to come into contact with the path bed so as to move the sheet. The contact is broken as soon as the leading edge of the sheet reaches the paper positioning plate. This series of operations is executed each time a sheet arrives.

When the leading edge of the first sheet reaches the paper positioning plate, the paper positioning plate paper sensor (PI8S) is turned ON. The arrival of the second and subsequent sheets will not be checked since the first sheet will still be over the sensor.

The crescent roller keeps rotating while sheets are being output, butting the leading edge of each sheet against the paper positioning plate, and ultimately, keeping the leading edge of the stack in order.

The alignment motor (M5S) drives the alignment plates for each sheet so as to put both left and right edges of the sheet in order.

- 1) The solenoid is turned ON while paper is being moved so that the feed plate comes into contact.

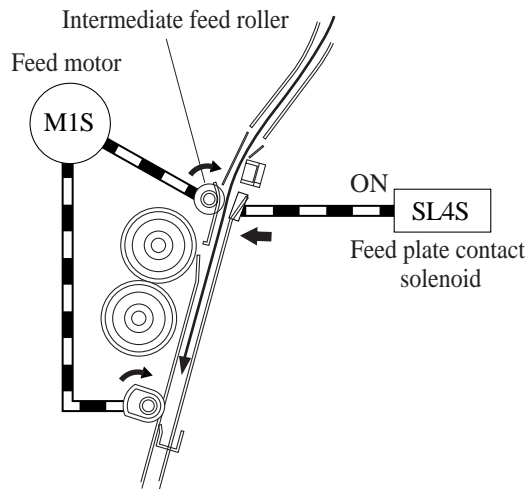

Figure 3-306

- 2) The solenoid is turned OFF when the paper butts against the paper positioning plate. The feed motor continues to rotate.

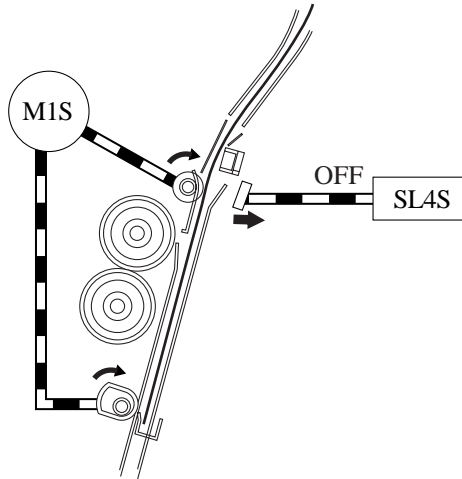

Figure 3-307

- 3) The solenoid is turned ON when the next sheet arrives and the feed plate comes into contact.

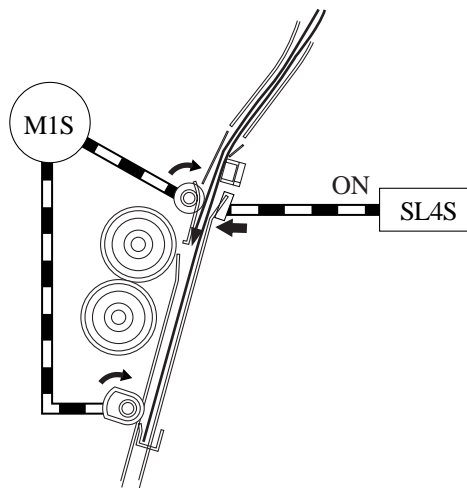

Figure 3-308

D. Aligning the Sheets

The alignment motor (M5S) drives the alignment plates each time a sheet is output, putting both left and right edges of the sheet in order. The alignment motor is a 4-phase stepping motor. The position of alignment plate is identified in reference to the number of motor pulses from the alignment plate home position sensor (PI5S).

The following briefly describes what takes place when the saddle stitching mechanism operates on two sheets.

- 1) When the first sheet has been output, the alignment plates butt against the left and right edges of the stack (first alignment). The alignment plates leave the home position in advance and remain in wait at points 10 mm from the edges of the stack.

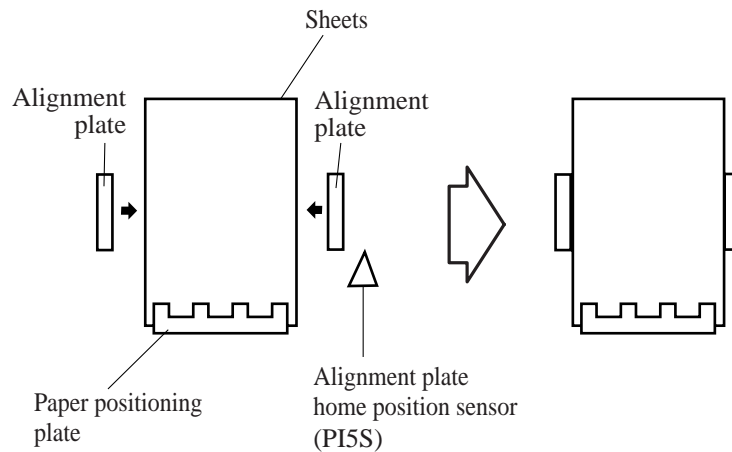

Figure 3-309

- 2) The alignment plates move away from the edges of the stack over a short distance and then butt against the edges once again (2nd alignment).

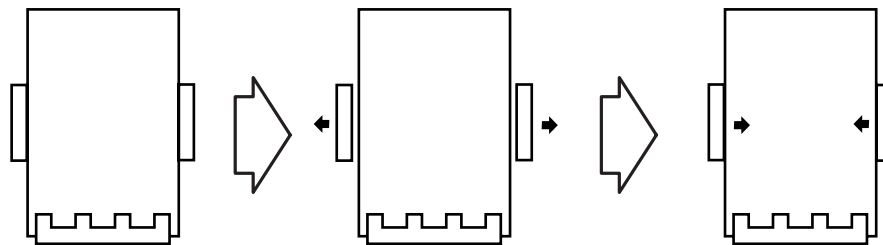

Figure 3-310

- 3) The alignment plates escape to points 10 mm from the edge of the stack.

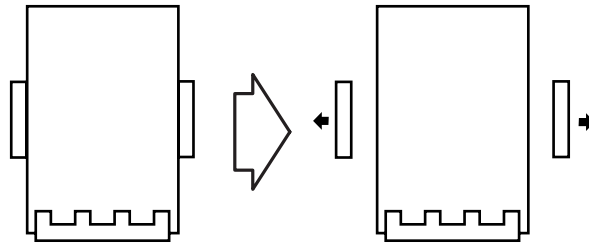

Figure 3-311

- 4) When the following stack arrives, steps 1 through 3 above are repeated.
 5) The alignment plates butt against the stack once again, during which stitching takes place.

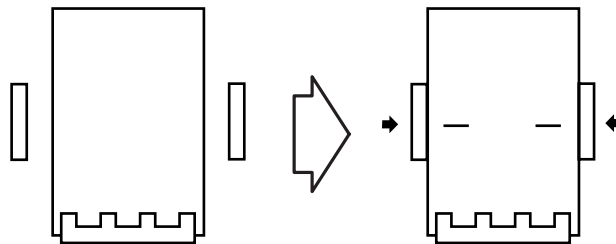

Figure 3-312

- 6) The alignment plates escape to points 10 mm from the edges of the stack, after which folding and delivery take place.

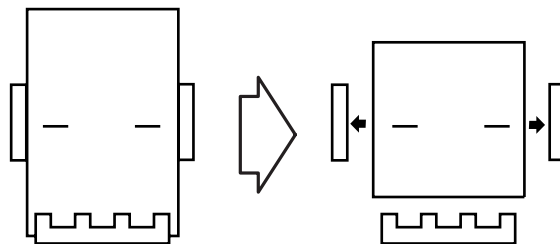

Figure 3-313

- 7) When the first sheet of the following stack reaches the No.1 paper sensor, the guide moves to a point 10 mm from the edge of the stack to be ready for the next alignment operation.

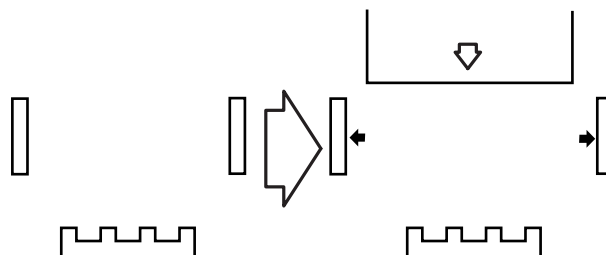
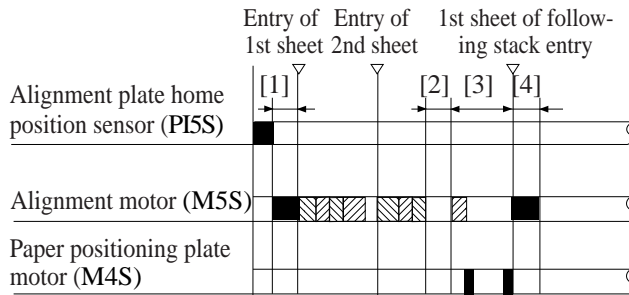

Figure 3-314

In case of 2 sheets:



▨ : Alignment ▩ : Escape

- [1]: Move to wait position
- [2]: Stapling period
- [3]: Paper folding/delivery period
- [4]: Move to following stack size wait position

Figure 3-315

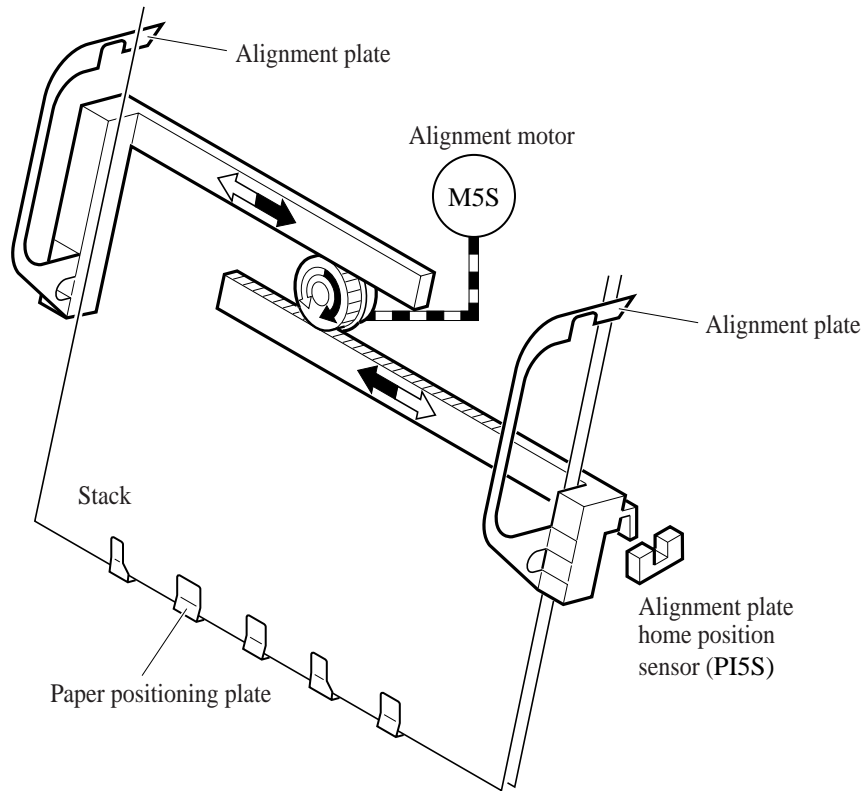

Figure 3-316

E. Controlling the Phase of the Crescent Roller

1. Outline

If alignment was executed with the crescent roller in contact with the stack of sheets, the resulting friction against the roller causes the stack to move inappropriately (Figure 3-317). To prevent this problem, the phase of the roller is identified and used to determine the timing of alignment.

The phase of the crescent roller is identified by the crescent roller phase sensor (PI12S). The flag for the crescent roller phase sensor is mounted to the crescent roller shaft. The flag will leave the sensor while the roller shaft rotates, turning the sensor ON or OFF, enabling the assumption that the crescent roller is positioned at the opposite side of the stack (Figure 3-319). The alignment plates are operated to correspond with this change in the state of the sensor.

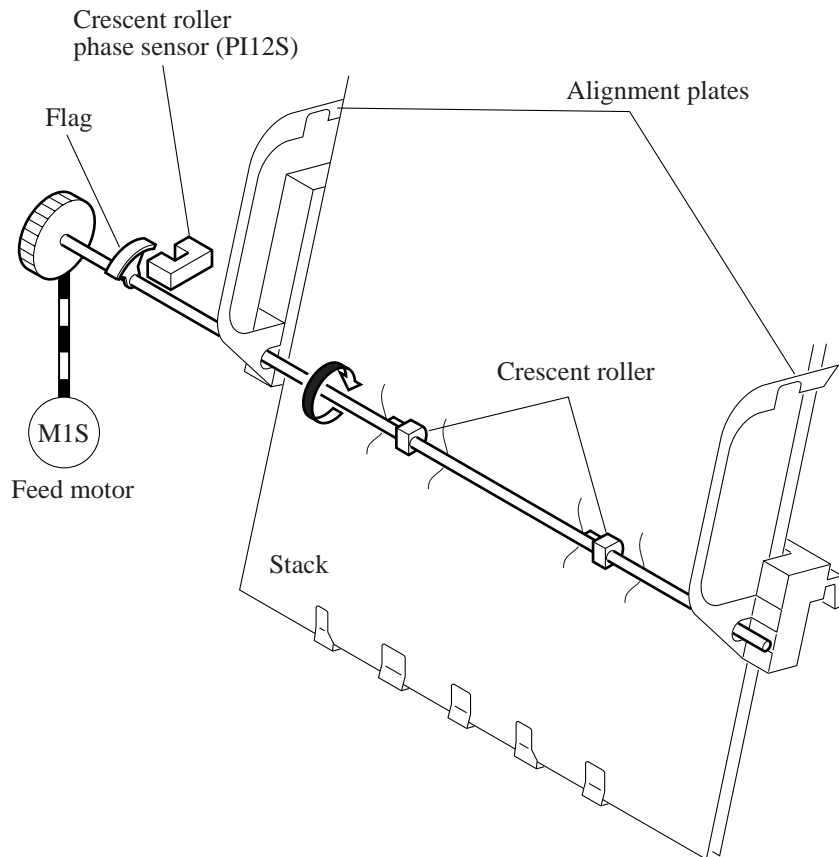

Figure 3-317

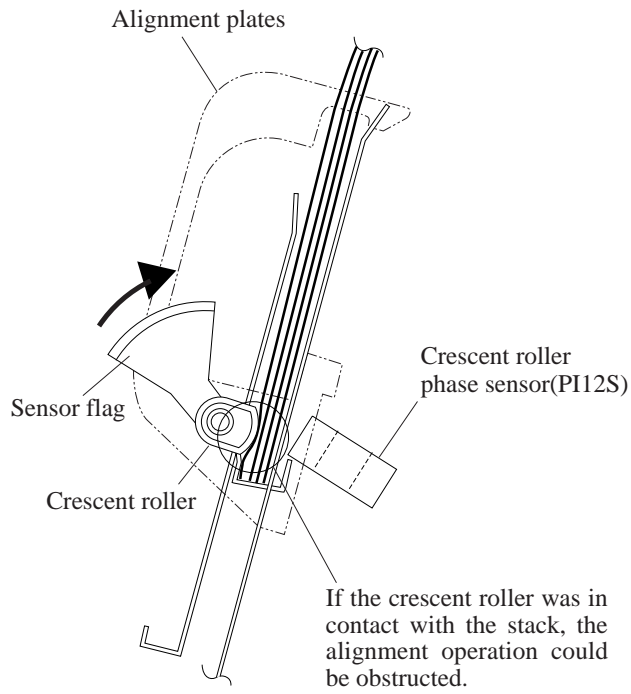

Figure 3-318

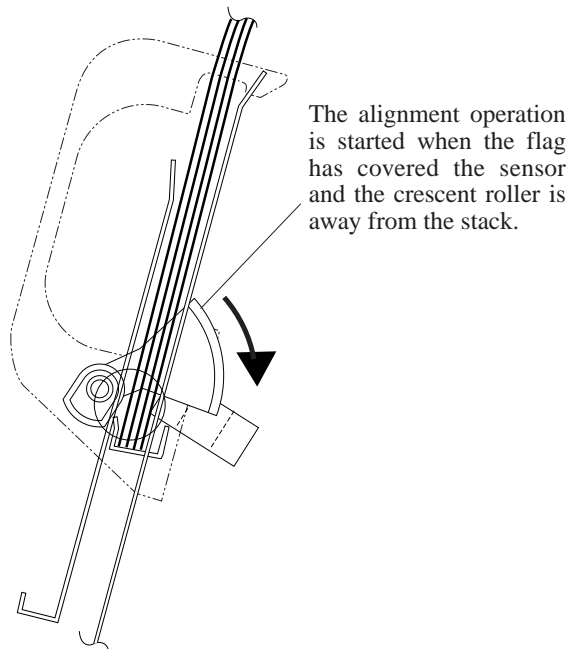

Figure 3-319

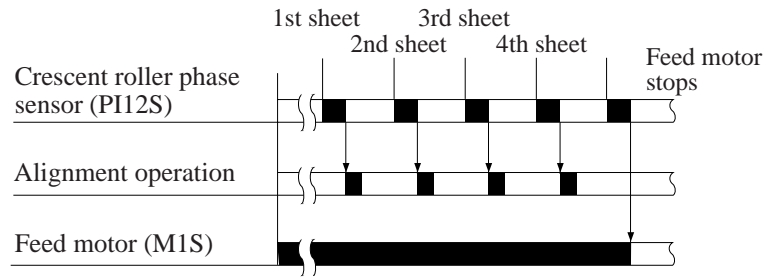

Figure 3-320

IV. STITCHING SYSTEM

1. Outline

The stitching system “stitches” the center of an output stack with staples.

To enable stitching at two locations on a stack, two stitcher units (front, rear) are used. Each stitcher unit is equipped with a stitcher motor (M7S, M6S) for drive, a stitcher home position sensor (MS7S, MS5S) for detection of position and a staple sensor (MS6S, MS4S) for detection of the presence/absence of staples.

The stitcher base is designed so that it may be drawn out to the front from the saddle stitcher for replacement of the staple cartridge or removal of a staple jam. The stitcher unit in sensor (PI16S) is used to make sure that the stitcher base is properly fitted to the saddle stitcher.

Safety switches are not mounted for the stitcher unit (front, rear), as the location does not allow access by the user.

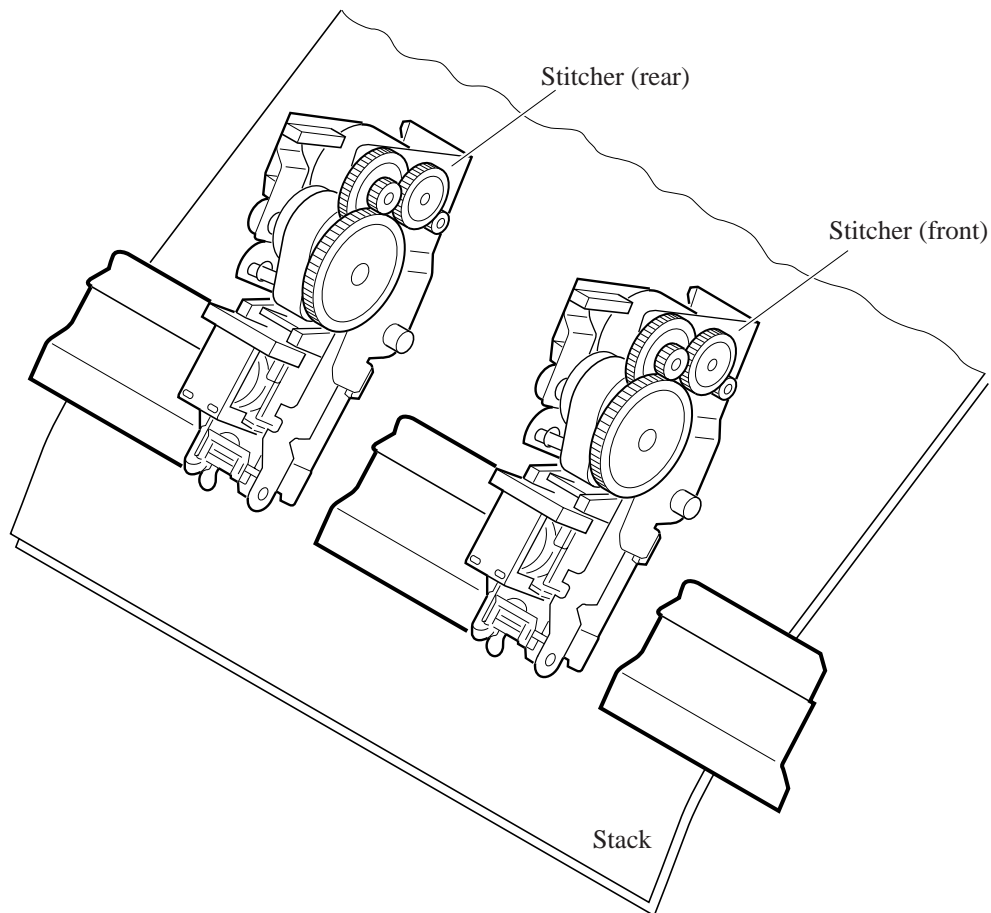

Figure 3-401

2. Stitcher Unit Operation

The stitcher base unit consists of two stitchers and stitcher bases. The stitchers are fixed in position, and are not designed to slide or swing.

Stitching is executed by driving the rotary cam by the stitcher motor (M7S, M6S). The front and rear stitcher units are operated with a time delay so as to prevent wrinkling of paper and to limit the load applied to the power supply. (A time delay for initiating the stitcher motor startup current helps decrease the load on the power supply.)

The stitcher home position sensor (MS7S, MS5S) is used to monitor the movement of the rotary cam, enabling identification of individual stitcher operations. The presence/absence of staples inside the staple cartridge fitted to the the stitcher is detected by the staple sensor (MS6S, MS4S).

The alignment plates keep both edges of the stack in place while stitching takes place.

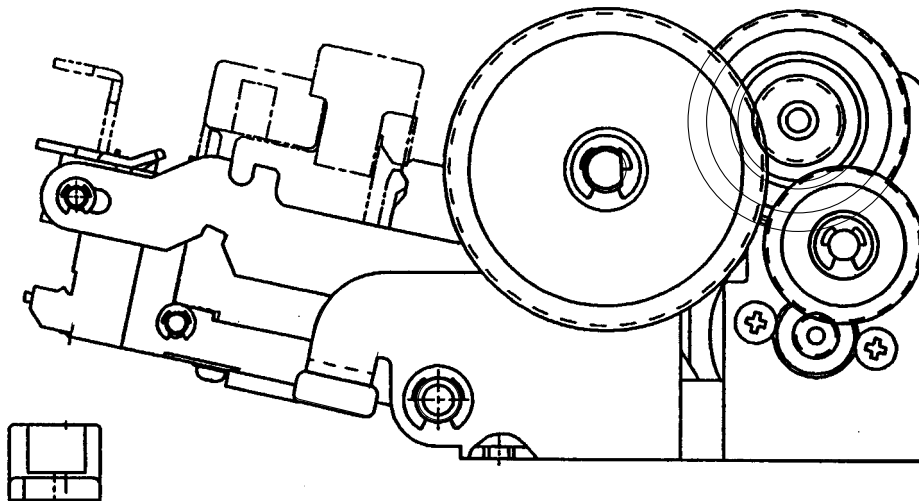

Figure 3-402

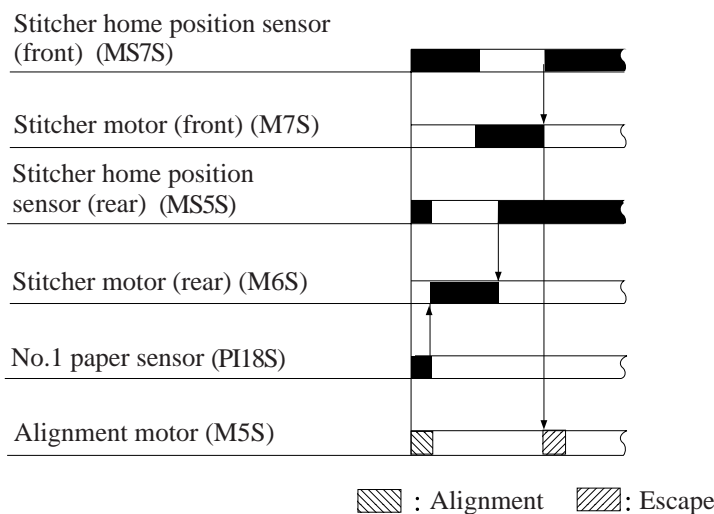

Figure 3-403

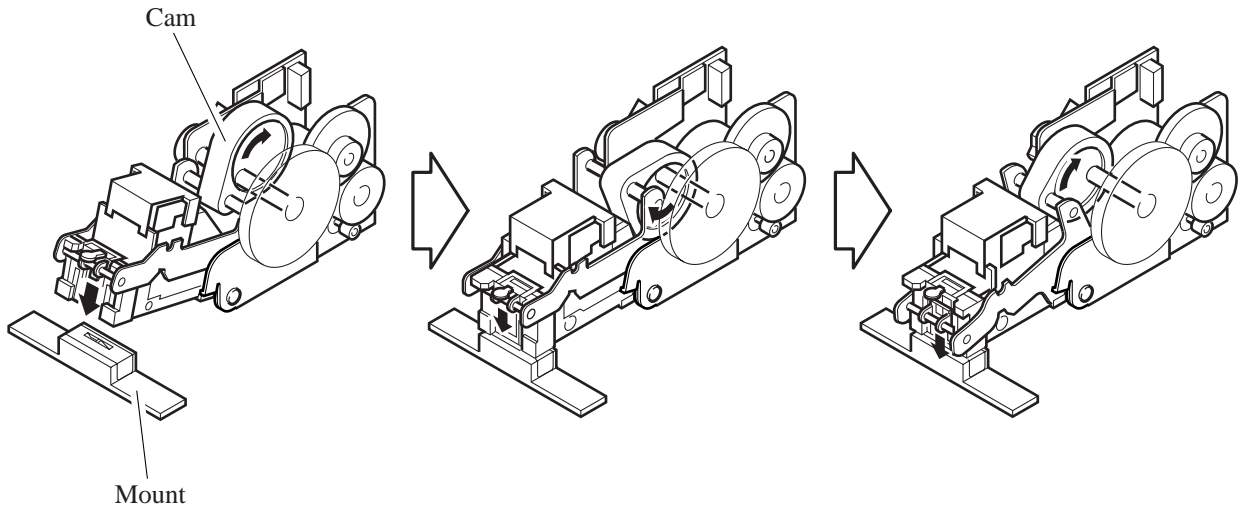

Figure 3-404

V. FOLDING/DELIVERY SYSTEM

1. Outline

The paper folding mechanism consists of a guide plate, paper folding rollers, paper pushing plate, and paper positioning plate.

The guide plate is used to cover the folding rollers while sheets are output as to prevent sheets from coming into contact with the folding rollers during output. Before the stack is folded, the guide plate moves down to enable the folding rollers to operate.

The folding rollers are driven by the paper folding motor (M2S), and the drive of the motor is monitored by the paper folding motor clock sensor (PI4S). The mechanism is also equipped with a paper folding home position sensor (PI21S) for detecting the position of the paper folding rollers.

The paper pushing plate is driven by the paper pushing plate motor (M8S), and the drive of the paper pushing plate motor is monitored by the paper pushing plate motor clock sensor (PI1S). The paper pushing plate home position sensor (PI14S) and the paper pushing plate top position sensor (PI15S) are used to detect the position of the paper pushing plate.

After being folded into two by the paper folding rollers, a stack is moved ahead by the delivery roller for delivery. The delivery roller is driven by the paper folding motor. The delivery sensor (PI11S) is mounted to the delivery assembly to detect delivery of paper. The tray paper sensor (PI6S) is used to detect the presence/absence of paper on the tray, but does not detect jams. The vertical path paper sensor (PI17S) serves to detect the presence of paper after jam removal.

2. Controlling the Movement of Stacks

When a stack has been stitched (2 points), the paper positioning plate lowers so that the stack will move to where the paper folding rollers come into contact with the stack and where the paper pushing plate is located. The position of the paper positioning plate is controlled in reference to the number of motor pulses coming from the paper positioning home position sensor (PI7S).

At the same time as the paper positioning plate operates, the guide plate lowers so that folding may take place.

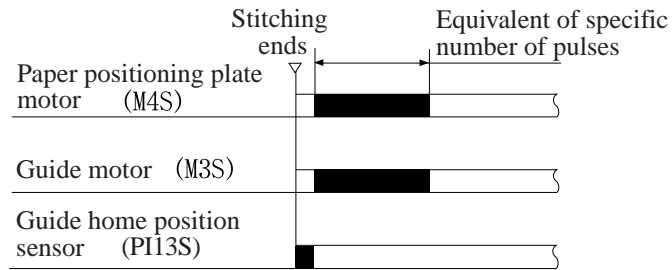

Figure 3-501

3. Folding a Stack

A stack is folded by the action of the paper folding rollers and the paper pushing plate.

The paper pushing plate pushes against the center of a stack toward the roller contact section. The paper pushing plate starts at its home position and waits at the leading edge position until the stack has been drawn to the paper folding roller and is gripped for a length of 10 mm. When the paper folding roller has gripped the stack for a length about 10 mm, the paper pushing plate motor starts to rotate once again, and the paper pushing plate returns to its home position. The stack gripped in this way by the paper folding roller is drawn further by the paper folding roller and then is moved by the delivery roller to the paper tray.

Half of the peripheral area of the paper folding rollers excluding the center part is punched out. This punched out area only feeds the paper as the paper feeding roller (lower) contacts the paper feeding roller (upper) only at the center of the roller to prevent the paper from wrinkling. As the paper feeding roller (lower) contacts the paper feeding roller (upper) at their entire surfaces on the remaining half of the peripheral area, paper folding starts from this half of the peripheral area, and paper is fed while it is being folded. The stop position of the paper folding rollers is in this half of the peripheral area.

The paper folding start and stop positions on the paper folding rollers is controlled according to the motor clock signals from the paper folding home position sensor (PI21S).

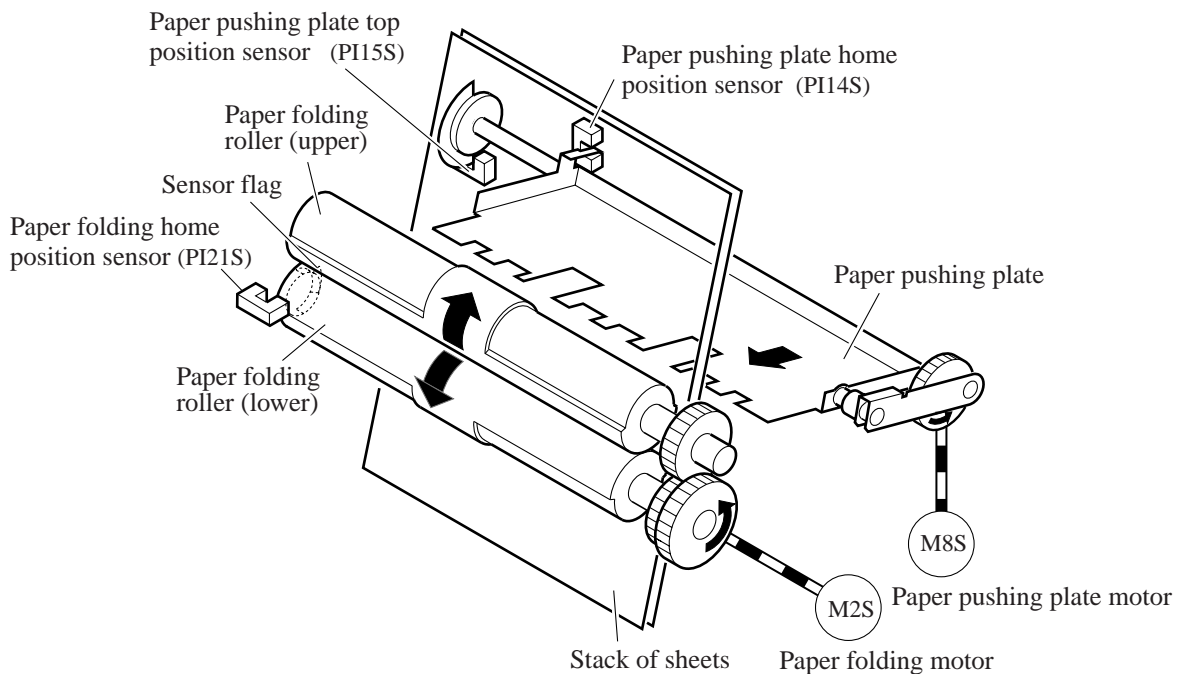

Figure 3-502

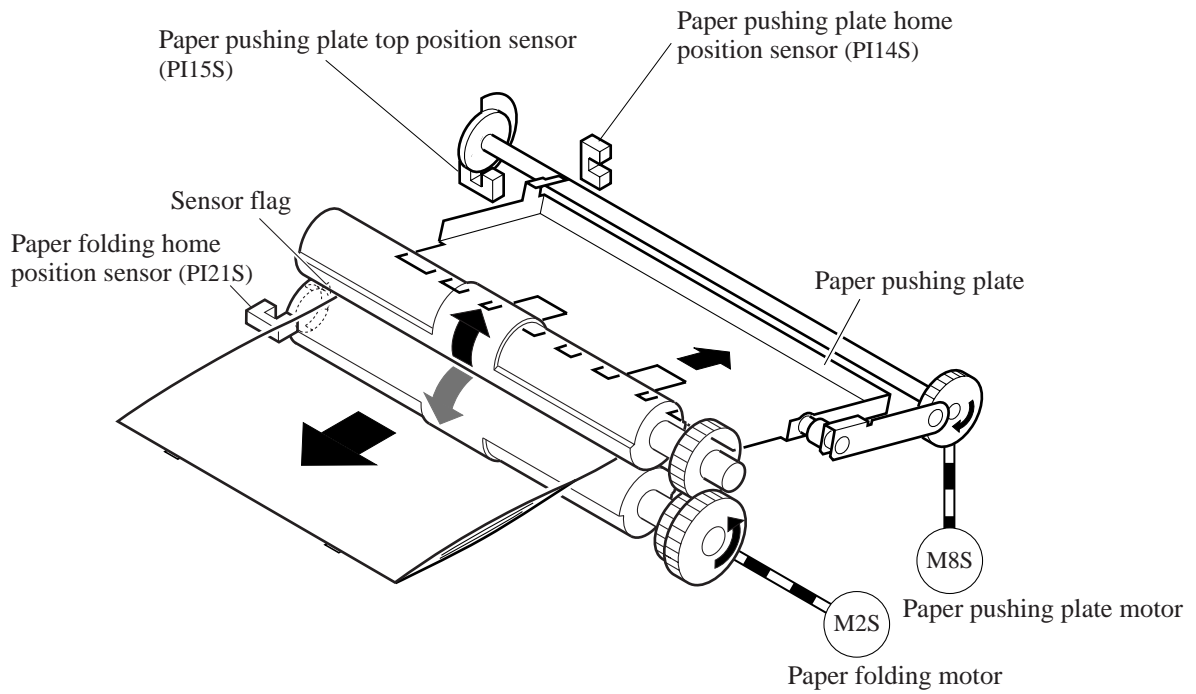

Figure 3-503

[Paper folding start position]

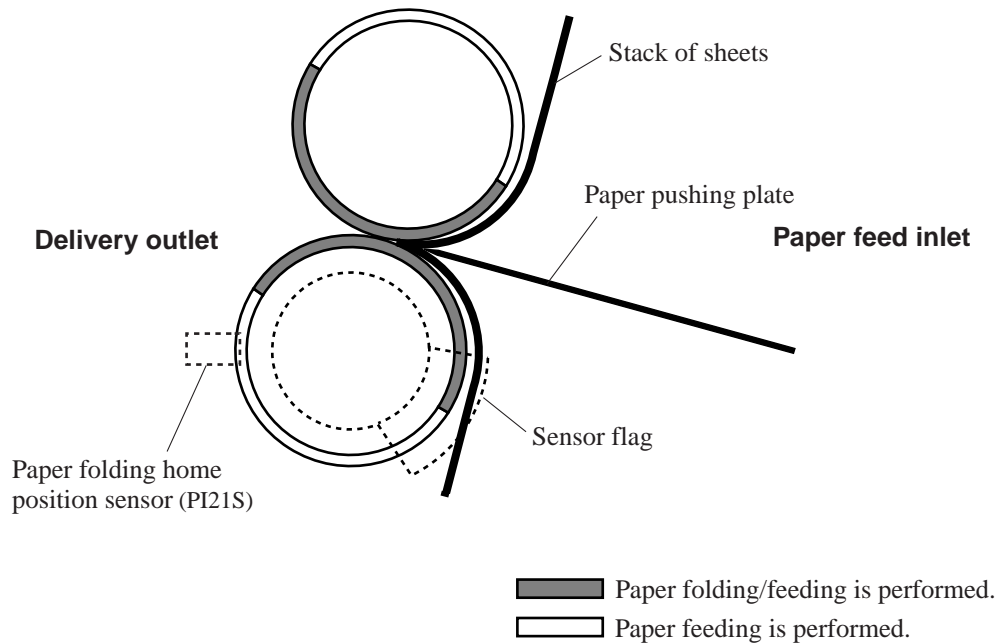

Figure 3-504

[Paper folding roller stop position]

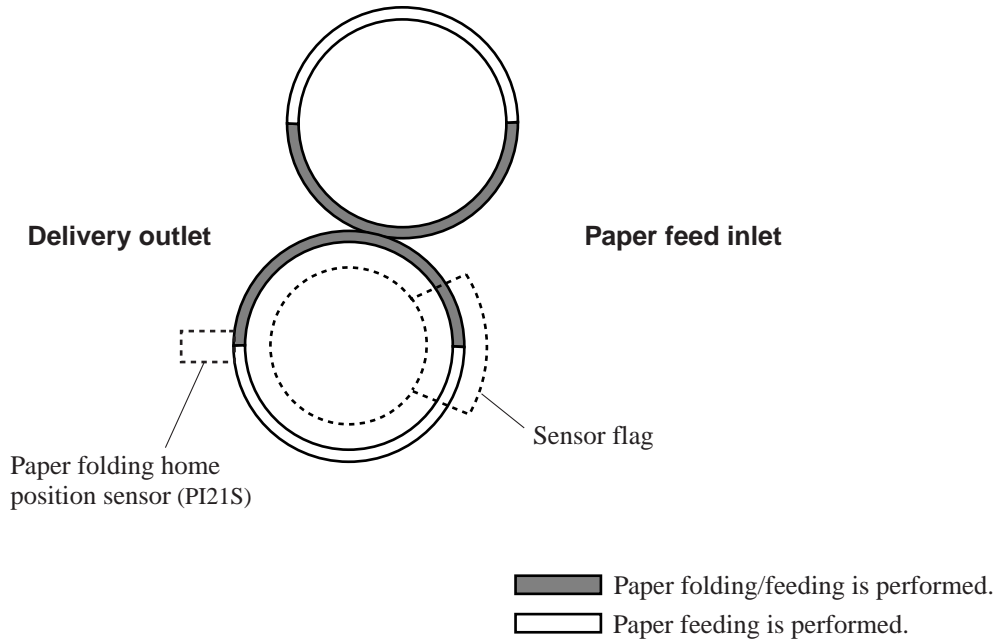

Figure 3-505

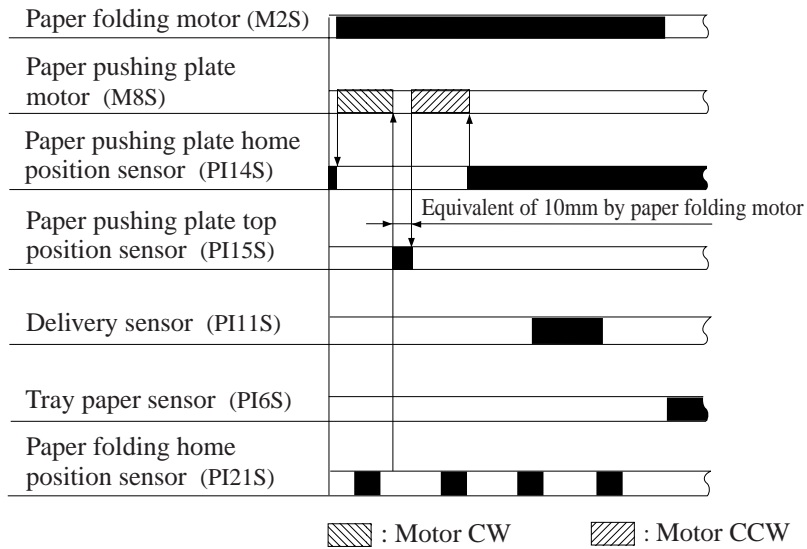

Figure 3-506

4. Double Folding a Stack

To fold a stack consisting of 10 or more A4-R or LT-R sheets, folding is executed twice for the same sheet.

The paper folding rollers rotate in reverse for an equivalent of 20 mm after gripping the stack for a length of 20 mm, enabling the paper folding rollers to apply an increased degree of pressure along the crease on the stack. Then, the paper folding rollers rotate normally, and the paper pushing plate returns to its home position while the stack is being delivered.

This way, a stack requiring a large force may properly be folded with less pressure.

- 1) The paper pushing plate pushes the stack in the direction of the paper folding rollers.

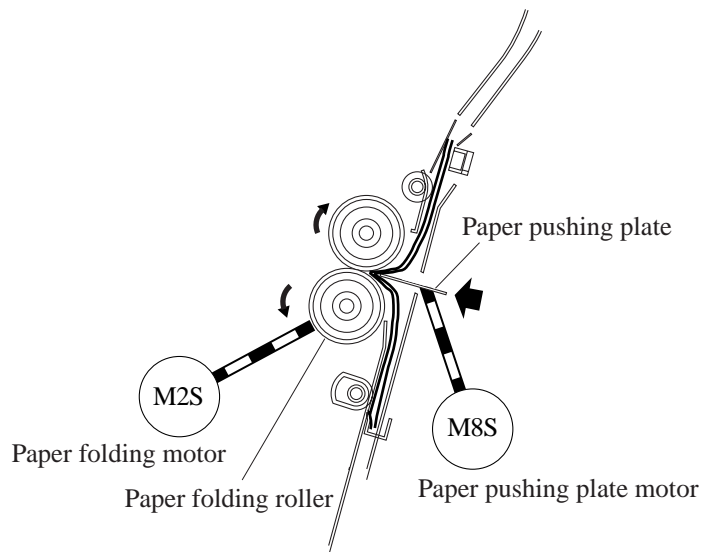

Figure 3-507

- 2) The paper folding rollers grip the stack for a length of about 20 mm.

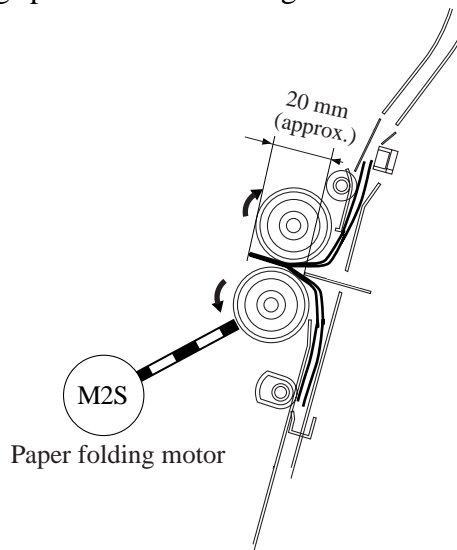

Figure 3-508

- 3) The paper folding rollers rotate in reverse, pushing back the stack for a length of about 20 mm (reverse feeding).

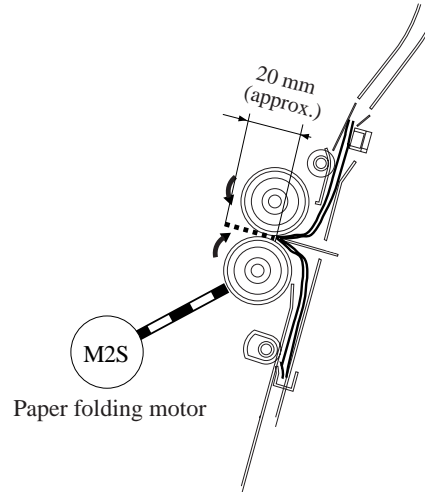

Figure 3-509

- 4) The paper folding rollers rotate again, feeding out the stack. The paper pushing plate returns to its home position.

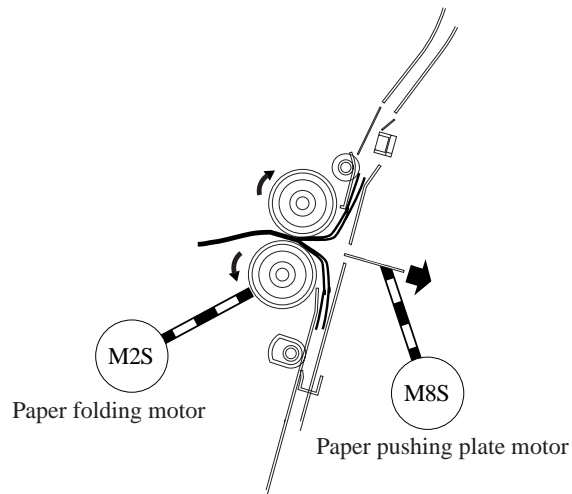

Figure 3-510

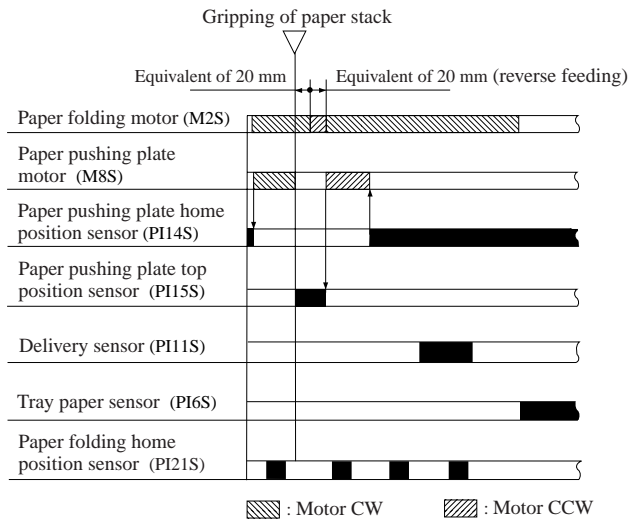

Figure 3-511

VI. CHECKING FOR A JAM

1. Checking for a Jam

The saddle stitcher unit identifies any of the following conditions as a jam, and sends the jam signal to the host machine. In response, the host machine may stop the copying operation and indicate the presence of a jam on its control panel.

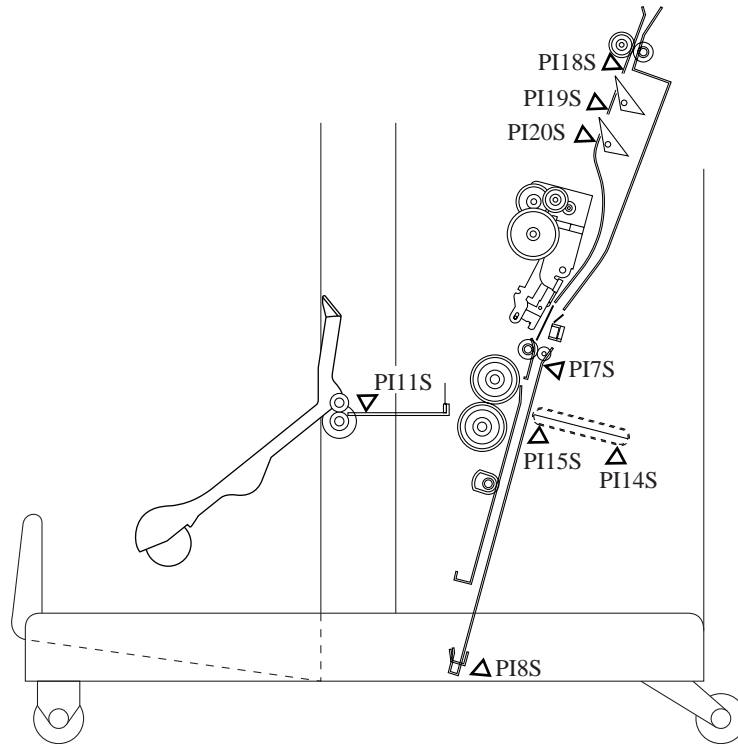

Figure 3-601

No.	Sensor
PI11S	Delivery sensor
PI14S	Paper pushing plate home position sensor
PI15S	Paper pushing plate top position sensor
PI17S	Vertical path paper sensor
PI18S	No.1 paper sensor
PI19S	No.2 paper sensor
PI20S	No.3 paper sensor
PI8S	Paper positioning plate paper sensor

Table 3-601

2. Inlet Delay Jam

The No.1 paper sensor (PI18S) on the paper sensor PCB does not come ON for a specific period of time after the inlet sensor (PI1) of the finisher has been turned ON.

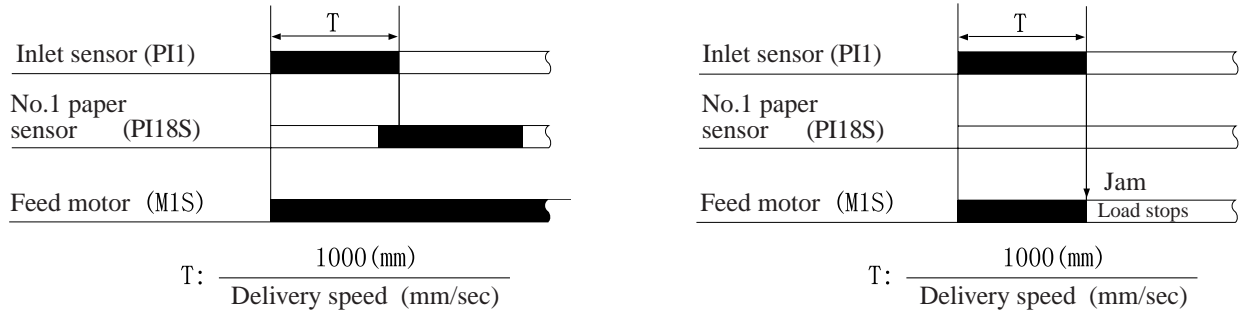

Figure 3-602

3. Inlet Stationary Jam

The No.1 paper sensor (PI18S), No.2 paper sensor (PI19S), and No.3 paper sensor (PI20S) on the paper sensor PCB do not go OFF when the stack has been fed for a specific period after the No.1 paper sensor (PI18S) is turned ON. The paper sensor used varies according to the paper size.

a. A3/LD Stack

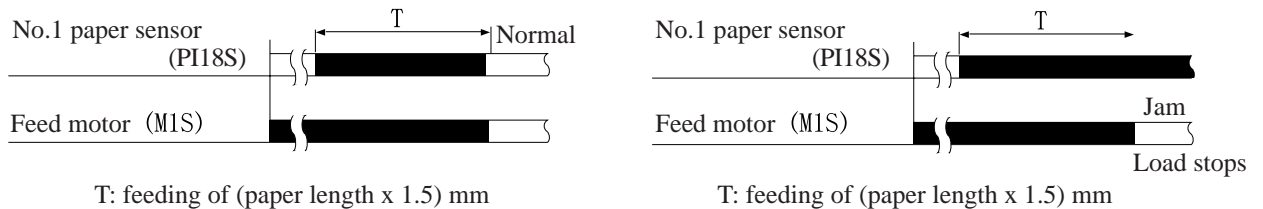
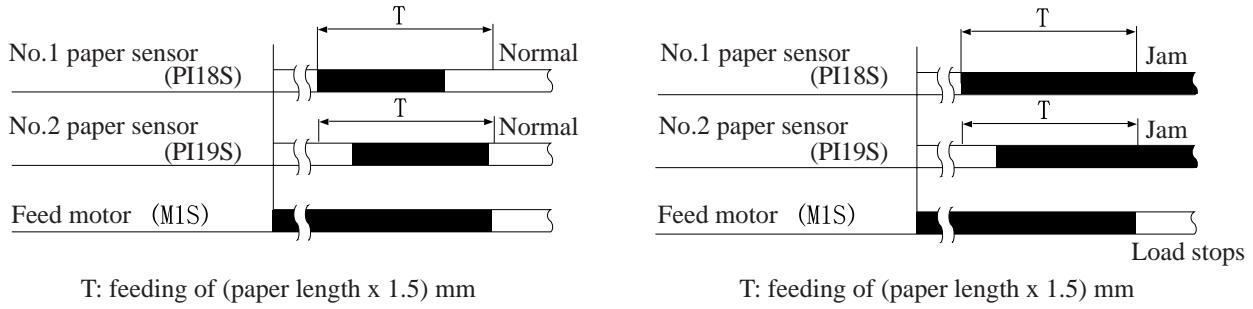

Figure 3-603

b. B4 Stack



Note: The diagram shows two sensors checking for jams. Single detection, however, uses only one sensor.

Figure 3-604

c. A4-R/LT-R Stack

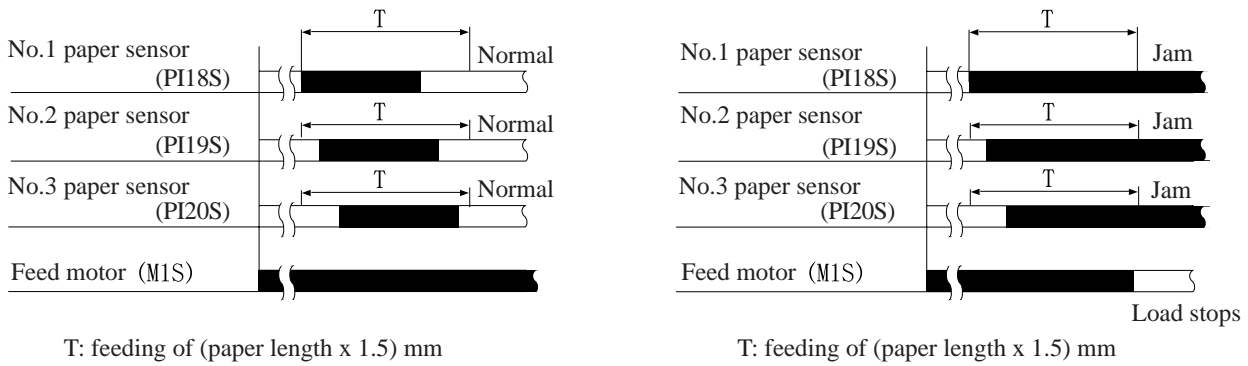

Note: The diagram shows three sensors checking for jams. Single detection, however, uses only one sensor.

Figure 3-605

4. Delivery Delay Jam

a. By delivery sensor

The delivery sensor (PI11S) does not come ON within a specific period of time after the paper pushing plate top position sensor has been turned ON.

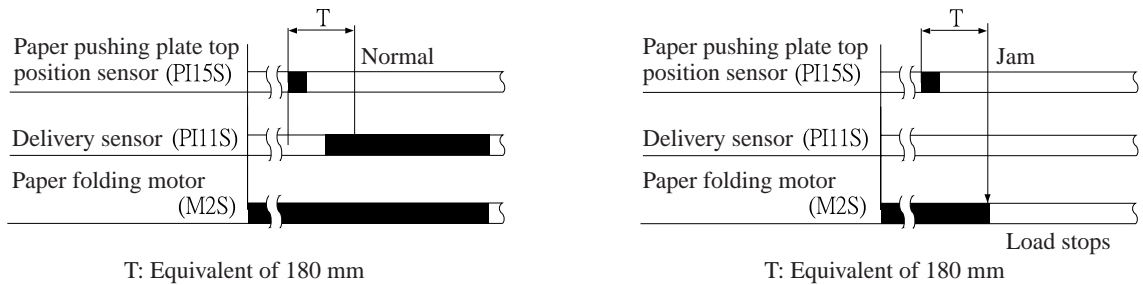
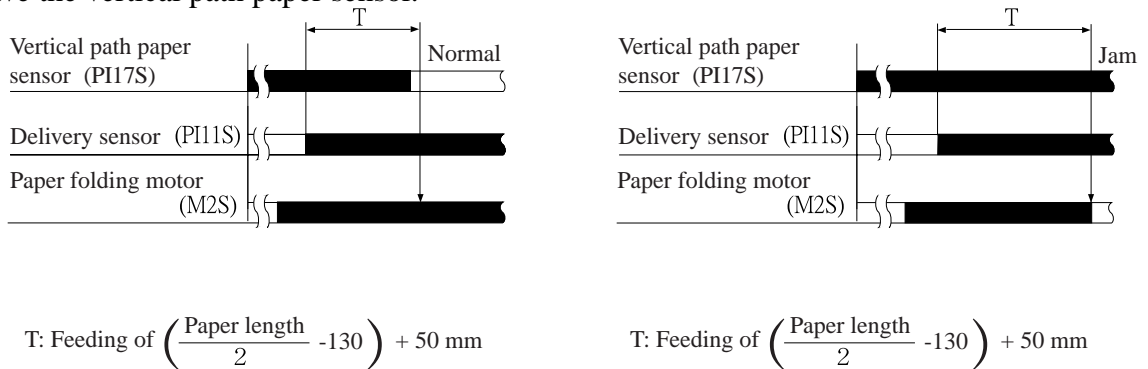

Figure 3-606

5. Delivery Stationary Jam

a. By vertical path paper sensor

The vertical path paper sensor (PI17S) does not go OFF within a specific period of time (feeding) after the delivery sensor (PI11S) has been turned ON, i.e., the trailing edge of the stack does not leave the vertical path paper sensor.



Note: The length 130 mm is the length of the feeding path from the vertical path paper sensor to the delivery paper sensor, while the length 50 mm is a margin.

Figure 3-607

b. By delivery sensor

The delivery sensor (PI11S) does not go OFF within a specific period of time (feeding) after it has been turned ON.

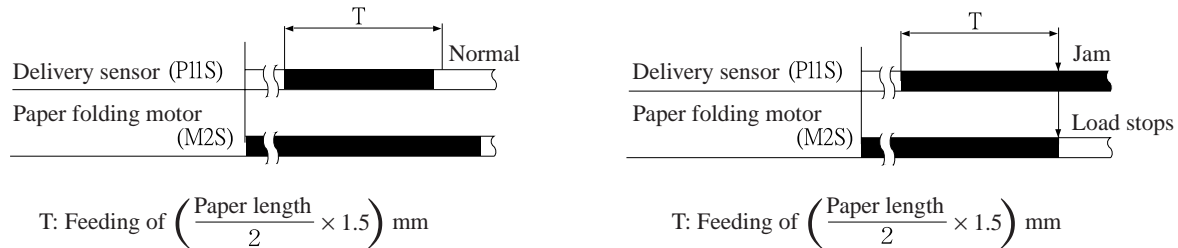

Figure 3-608

6. Power-ON Jam

Any of the No.1 paper sensor (PI18S), No.2 paper sensor (PI19S), No.3 paper sensor (PI20S), Vertical path paper sensor (PI17S) and delivery sensor (PI11S) on the paper sensor PCB detects paper at power-ON.

7. Door Open Jam

The front door open/closed sensor (PI2S), outlet cover sensor (PI3S), or inlet cover sensor (PI9S) finds that the respective cover is open during operation.

8. Stitcher Staple Jam

When the stitcher motor (M7S/M6S) is rotating clockwise, the stitcher home position sensor (MS7S/MS5S) does not come ON within 0.5 sec after it has been turned OFF. In addition, the sensor is turned ON within 0.5 sec after the motor has been rotated counterclockwise.

Reference:

When all doors are closed after the user has removed the jam, the saddle stitcher unit checks whether the vertical path paper sensor (PI17S) has detected the presence of paper. If the sensor has detected paper, the unit will identify the condition as being faulty jam removal and send the jam signal to the host machine once again.

VII. POWER SUPPLY

1. Outline

When the host machine power switch is turned ON, two 24V power lines are supplied by the finisher controller PCB.

The 24V line is used to drive motors and solenoids. The 24V power from the finisher controller PCB to solenoids does not pass through any protective mechanisms (microswitches, or the like).

The 24V power to motors, on the other hand, will not be supplied if any of the three door switches is open. Another 24V line is used to generate 5V to the sensors.

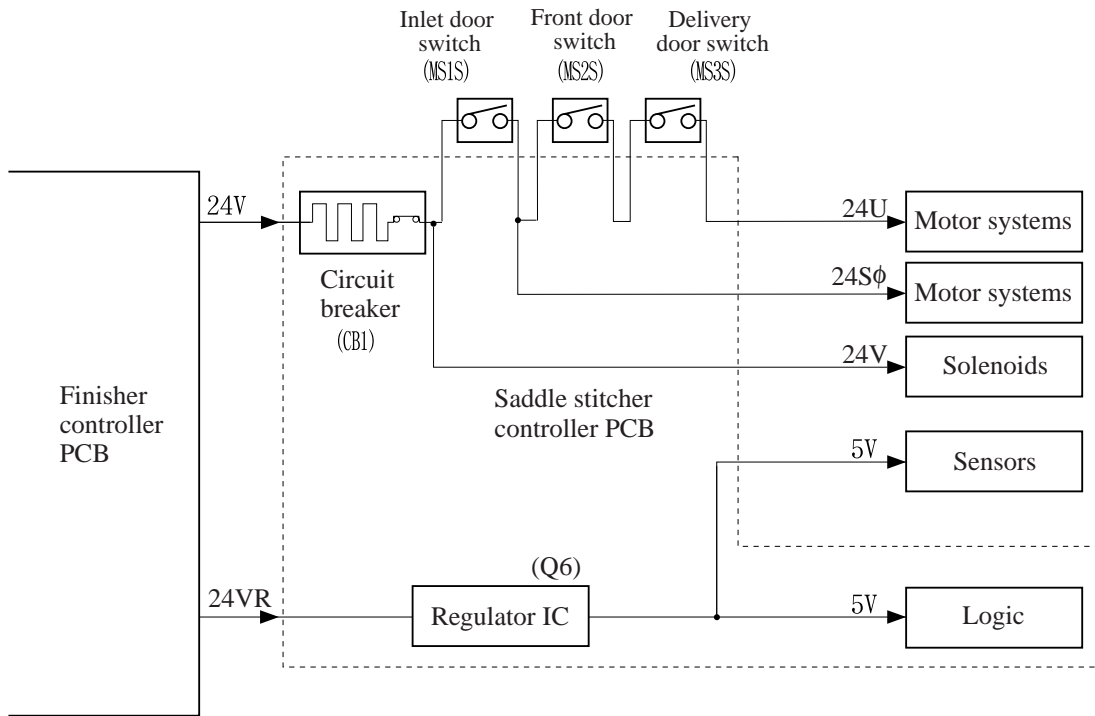

Figure 3-701



2. Protective Mechanisms

The 24 VDC power supply used for motors and solenoids is equipped with a circuit breaker (CB1). The 24V power supply used to drive the feed motor (M1S), guide motor (M3S), and the paper positioning plate motor (M4S) is equipped with a fuse designed to blow when an overcurrent flows.

CHAPTER 4

PUNCHER UNIT (OPTION) BASIC OPERATION

1. This chapter discusses the purpose and role of each of the puncher unit's functions, and the principles of operation used for the puncher unit mechanical and electrical systems. It also explains the timing at which these systems are operated.

The  symbol in drawings indicates transmission of mechanical drive, and signals marked by  together with the signal name indicates the flow of electrical signals.

2. In descriptions of digital circuits on the puncher unit, "1" indicates a high signal voltage level, while "0" indicates a low signal voltage level. Voltage values differ according to circuit.

Descriptions in this chapter also assume that PCBs will not be repaired at user sites. For this reason, descriptions of circuits on PCBs is limited to block diagrams. Two types of block diagrams are provided for separate functions: diagrams indicating details from sensors up to input sections of major PCBs, and diagrams indicating details from the output sections of major PCBs up the loads.

I. BASIC OPERATION	4-1	A. Outline	4-5
A. Outline	4-1	B. PUNCH OPERATION	4-7
B. Inputs to and Outputs from Punch Driver PCB	4-2	C. Horizontal Registration Operation	4-11
II. PUNCH OPERATION	4-5	III. POWER SUPPLY SYSTEM	4-14

I. BASIC OPERATION

A. Outline

The puncher unit (option) is attached on the feed path between the host machine and the finisher.

The puncher unit does not have a paper feed mechanism. Paper from the host machine is fed by feed drive from the finisher via the puncher unit. When the trailing edge of the paper from the host machine reaches the puncher unit, the paper stops temporarily, and the punch shaft is rotated to punch the trailing edge of the paper. This operation is controlled by the finisher controller PCB, and each of the parts on the finisher is driven by the punch driver PCB.

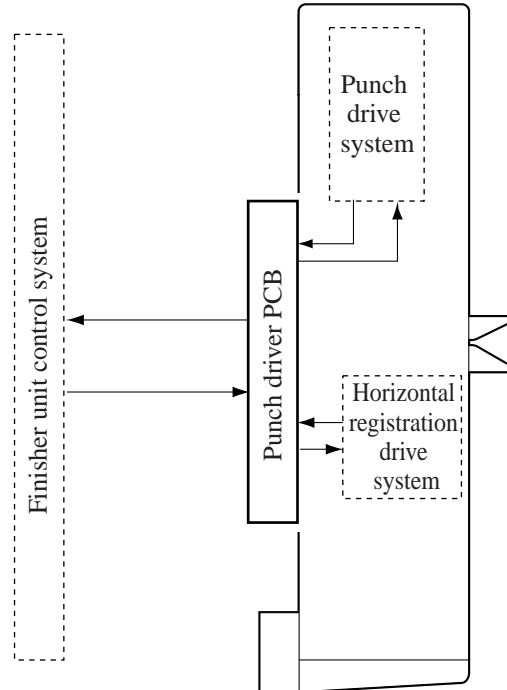

Figure 4-101

B. Inputs to and Outputs from Punch Driver PCB

1. Inputs to Punch Driver PCB (1/3)

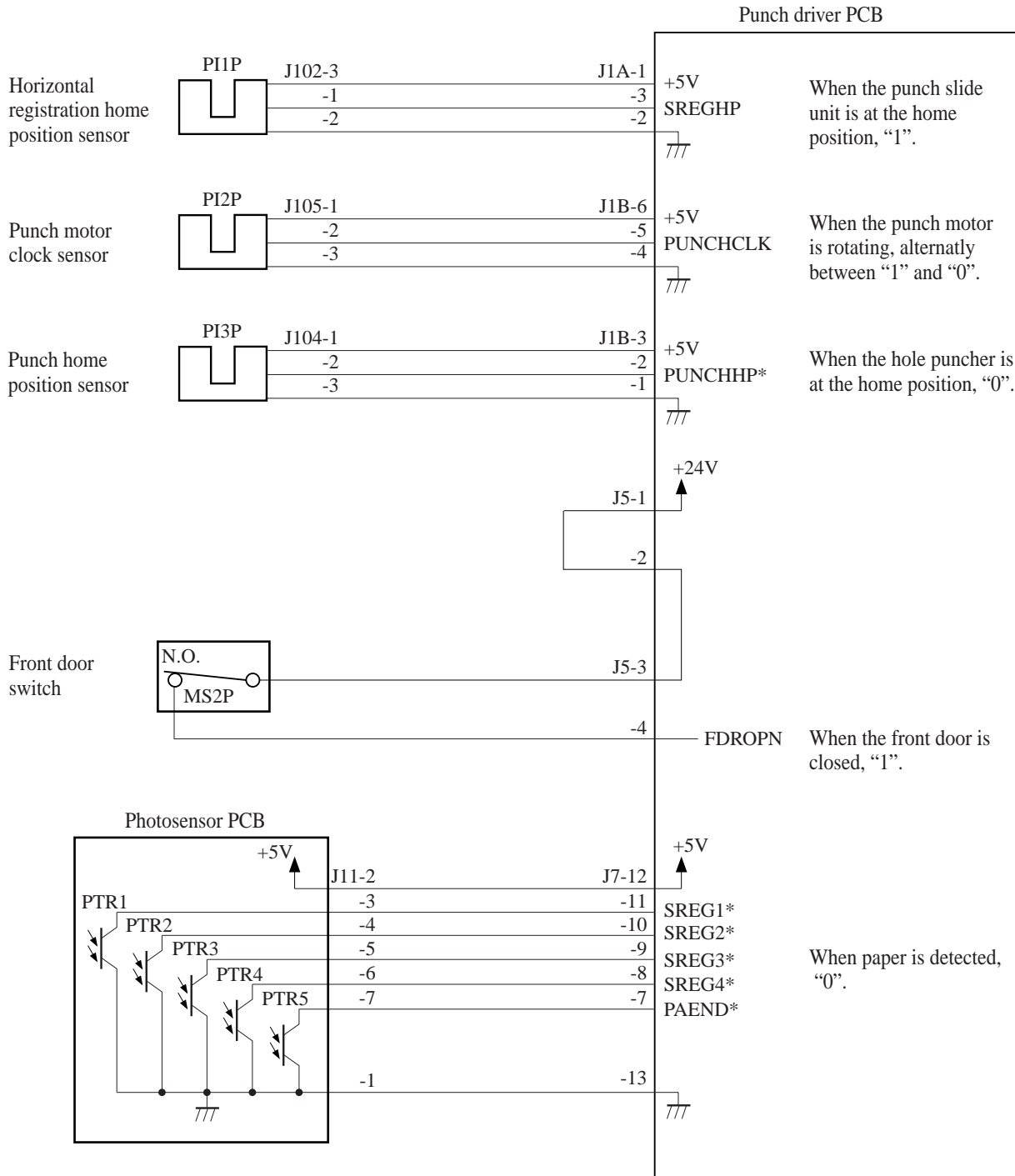

Figure 4-102

2. Outputs from Punch Driver PCB (2/3)

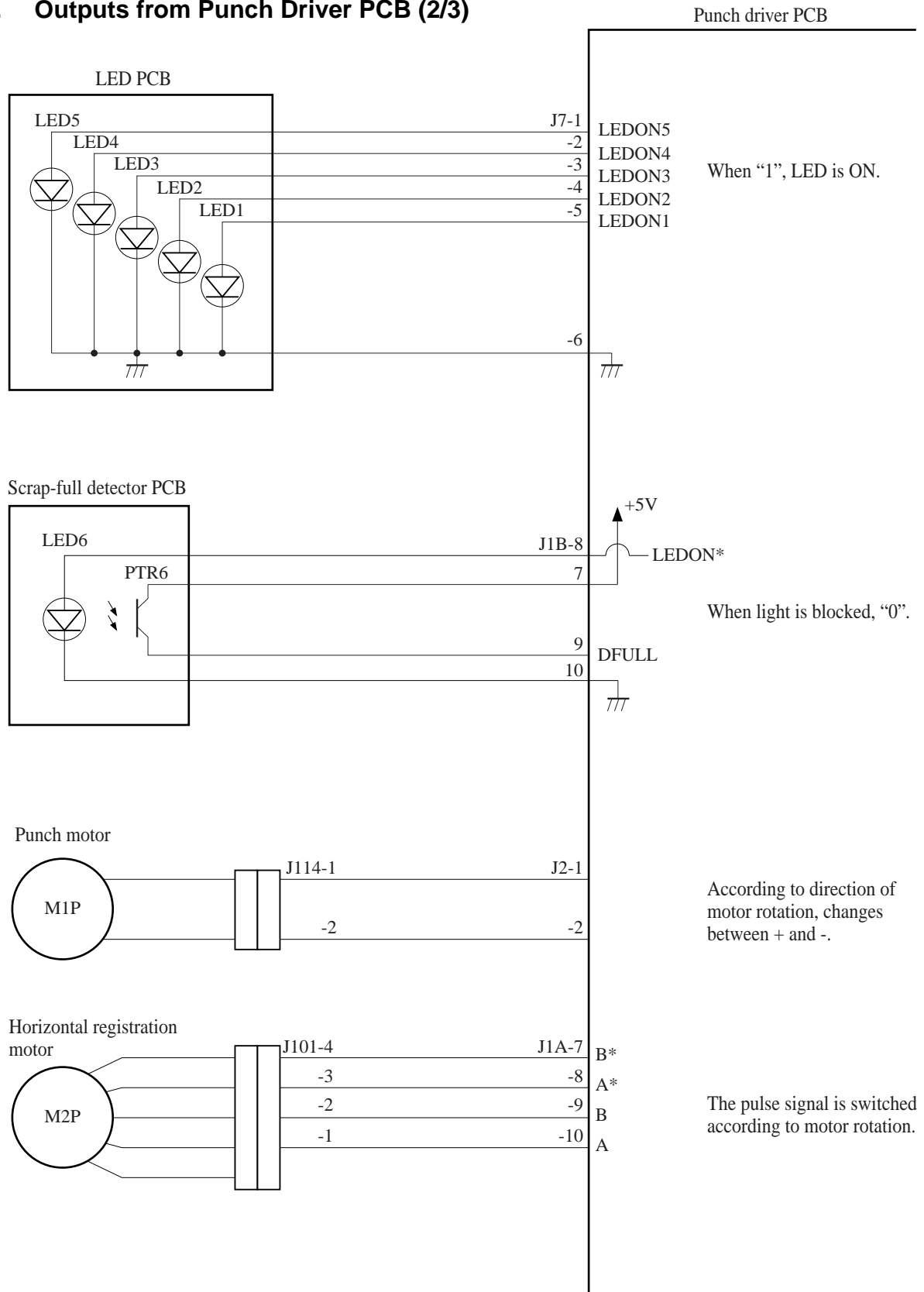

Figure 4-103

3. Outputs from Punch Driver PCB (3/3)

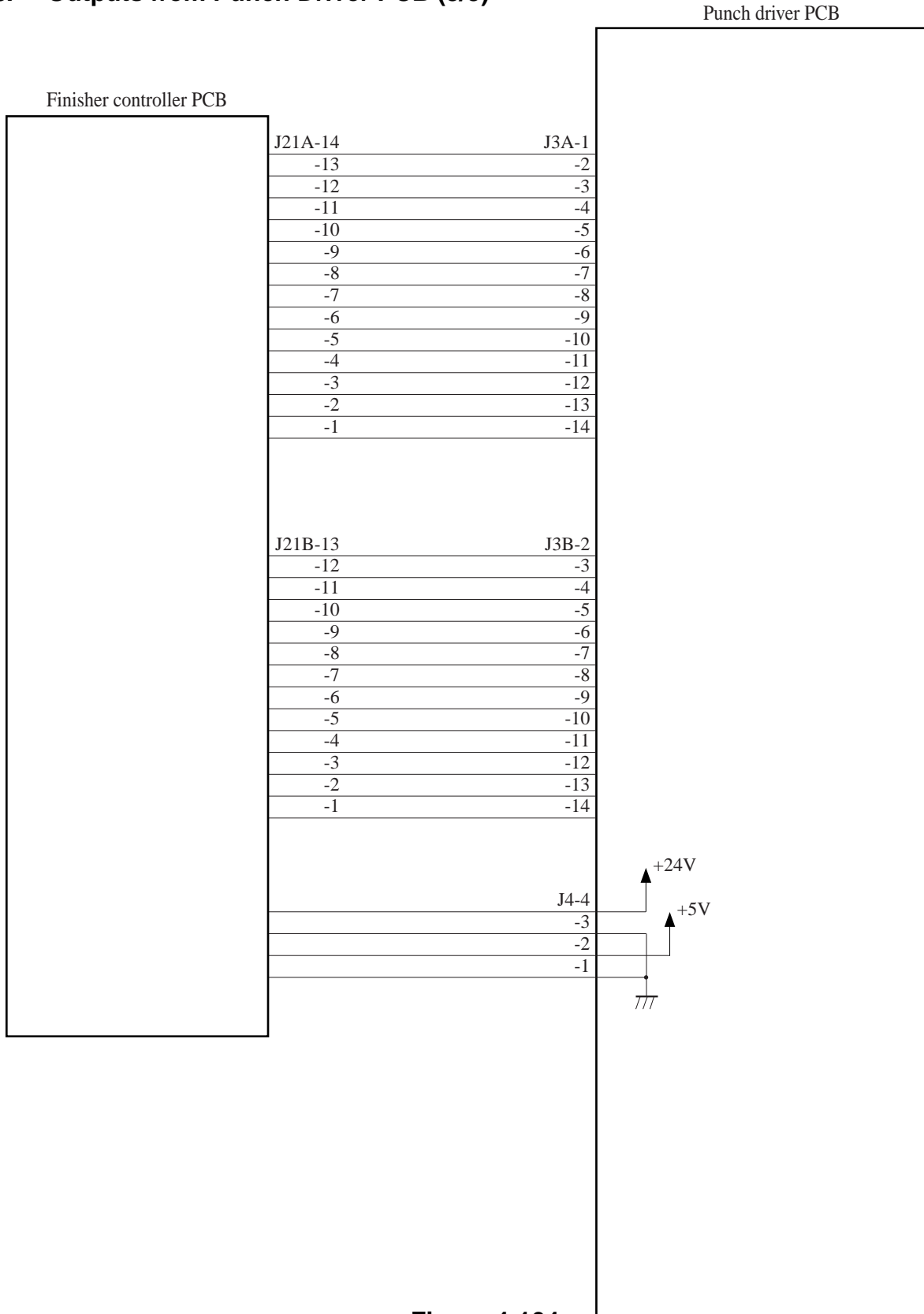

Figure 4-104

II. PUNCH OPERATION

A. Outline

The puncher unit is located on the feed path between the host machine and the finisher, and successively punches holes when the paper stops temporarily. When the trailing edge of the paper reaches the puncher unit, the inlet roller of the finisher unit temporarily stops the paper and holes are punched on the trailing edge of the paper.

The puncher unit consists of a die and hole puncher (punch blade).

The hole puncher is driven by the punch motor (M1P). The hole puncher is attached to the eccentric cam of the punch shaft, and rotary action of the punch shaft is converted to reciprocal motion to perform punching.

Punch motor (M1P) is a DC motor. The home position of the punch shaft is detected by punch home position sensor (PI3P). To stop the DC punch motor accurately at its home position, the punch motor clock sensor (PI2P) counts a predetermined number of clock pulses to stop the punch motor. A single punch operation is performed by rotating the punch shaft 180° from its home position.

Five light sensors (photosensor PCB) are located at the upper side of the inlet paper feed path of the puncher unit and a set of five LEDs (LED PCB) are located at the lower side. These sensors and LEDs function as five sensors. The frontmost sensor (LED5, PTR5) are the trailing edge sensor and are used for detecting the trailing edge of the paper. The remaining sensors (LED1 to LED4, PTR1 to PTR4) are horizontal registration sensors, and are used for detecting the inner position of the paper for determining the hole punching position.

The punch motor, puncher unit and above sensors comprise the punch slide unit. This unit moves backwards and forwards according to the size of the paper. Backward and forward movement is driven by the horizontal registration motor (M2P). The home position of the punch slide unit is detected by the horizontal registration home position sensor (PI1P). The horizontal registration motor (M2P) is a 2-phase stepping motor.

The punch motor and horizontal registration motor is driven by the punch driver PCB according to control signals from the finisher controller PCB.

Punch scraps caused by punching are stored in the punched scrap container. Scrap full detection is performed by a reflective sensor (LED6 and PTR6 on the scrap full detector PCB unit).

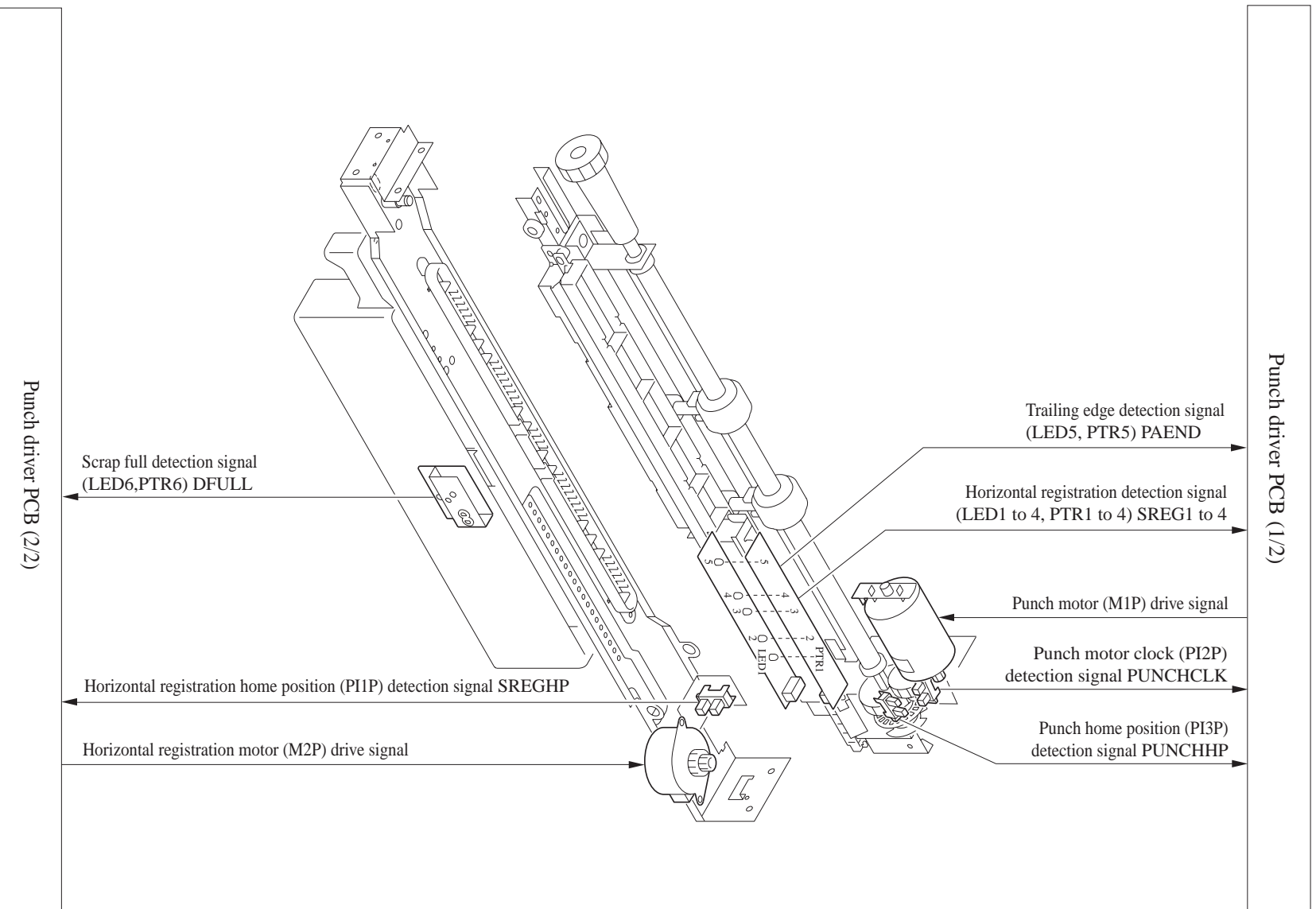

Figure 4-201

B. PUNCH OPERATION

The hole puncher is driven by the punch motor (M1P). The hole puncher home position is detected by the punch home position sensor (PI3P).

In all there are four types of puncher unit depending on the destination: 2-hole type (Puncher unit MJ-6002E), 2-/3-hole Dual Use (Puncher unit MJ-6002N), and two 4-hole types (Puncher unit MJ-6002F and Puncher unit MJ-6002S). With the 2-hole and 4-hole types, the hole puncher is moved reciprocally and punching is performed by the punch shaft rotating 180° from its home position. With the 2-/3-hole dual use type, too, the hole puncher is moved reciprocally and punching is performed by the punch shaft rotating 180° from its home position. However, half of the peripheral area of the punch shaft can be used as a 2-hole type while the other half can be as a 3-hole type. Whether the punch shaft is used as a 2-hole punch or a 3-hole punch depends on the instructions from the host machine.

1. 2-/4-hole Type

At the home position, the punch home position sensor is ON. Punching of the first sheet ends when the punch shaft has rotated in the forward direction 180°, and the state of the punch home position sensor has changed from OFF to ON. Punching of the second sheet ends when the punch shaft has rotated in the reverse direction 180°, and the state of the punch home position sensor has changed from OFF to ON.

The following illustrates punching when two sheets are punched.

- 1) A hole is punched in the trailing edge of the first sheet.

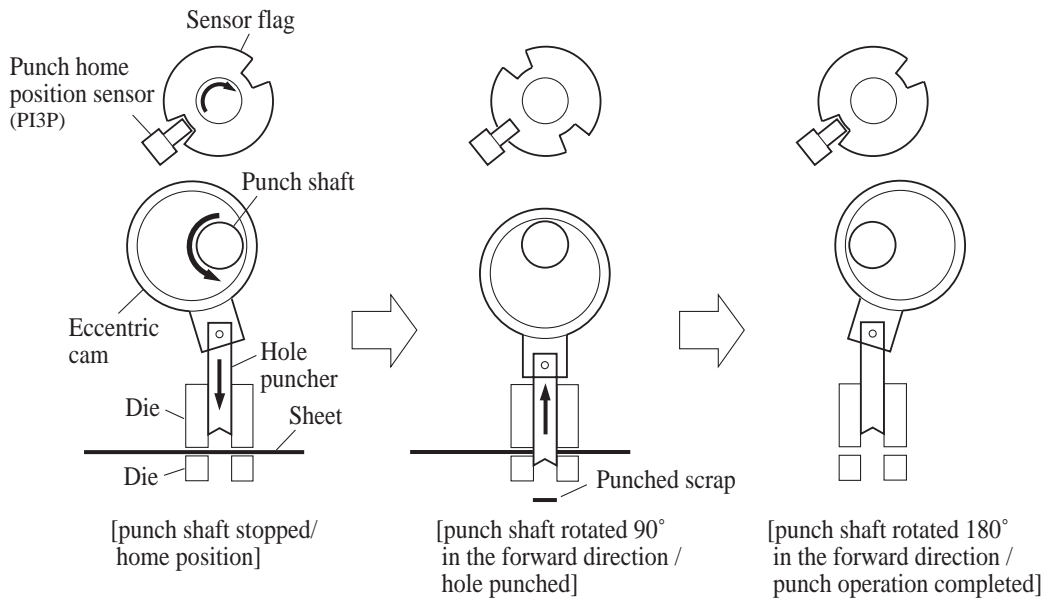

Figure 4-202

2) A hole is punched in the trailing edge of the second sheet.

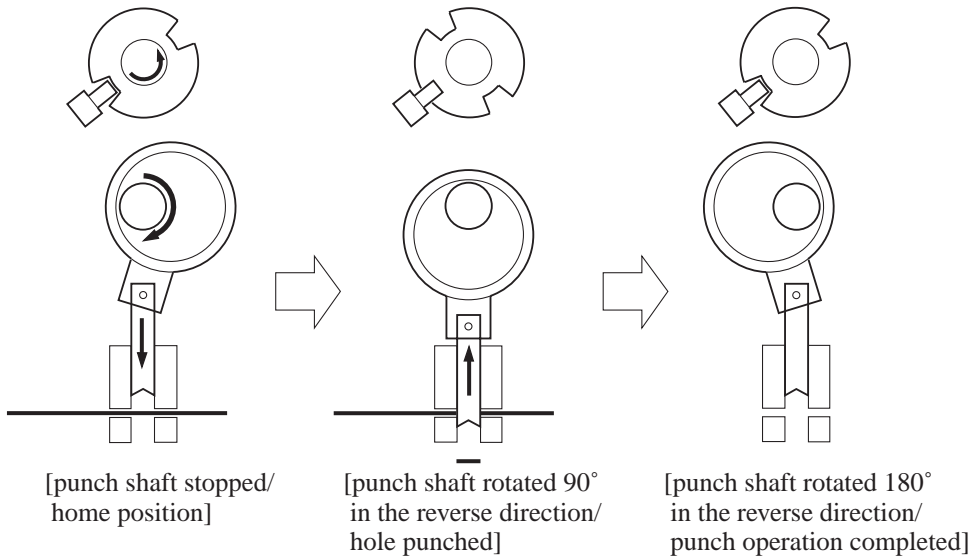

Figure 4-203

2. 2-/3-hole Dual Use Type

At the home position, the punch home position sensor is ON. To punch two holes, punching of the first sheet ends when the punch shaft half peripheral area has rotated in the forward direction 180°, and the state of the punch home position sensor has changed from OFF to ON. At this time, the 3-hole puncher is moved reciprocally in the escape direction (hole puncher rise direction) on the remaining half peripheral area on the punch shaft. Punching of the second sheet ends when the punch shaft half peripheral area has rotated in the reverse direction 180°, and the state of the punch home position sensor has changed from OFF to ON. Also at this time, the 3-hole puncher is moved reciprocally in the escape direction (hole puncher rise direction) on the remaining half peripheral area on the punch shaft. To punch three holes, the 2-hole puncher is moved reciprocally in the escape direction (hole puncher rise direction).

The following illustrates punching when two sheets are punched with two holes.

- 1) A hole is punched in the trailing edge of the first sheet.

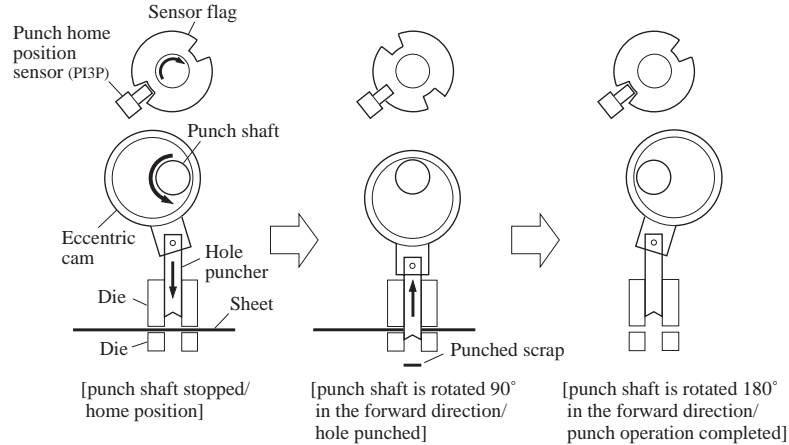

Figure 4-204

When two holes are punched, the 3-hole puncher is fed reciprocally in the escape direction (hole puncher rise direction) as shown below.

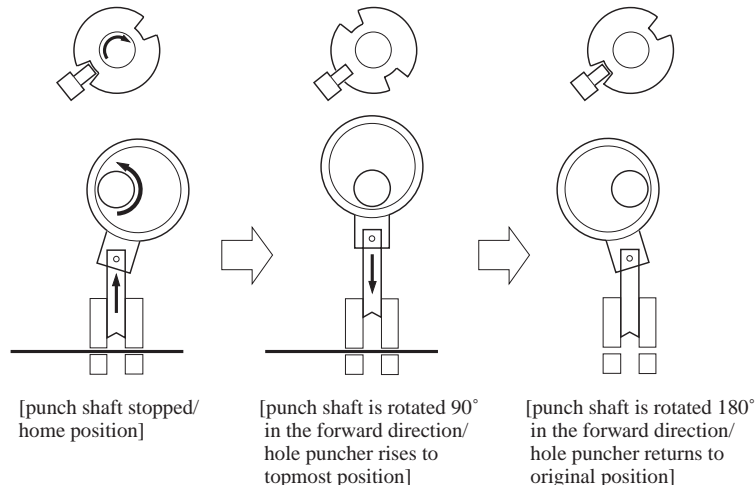

Figure 4-205

2) A hole is punched in the trailing edge of the second sheet.

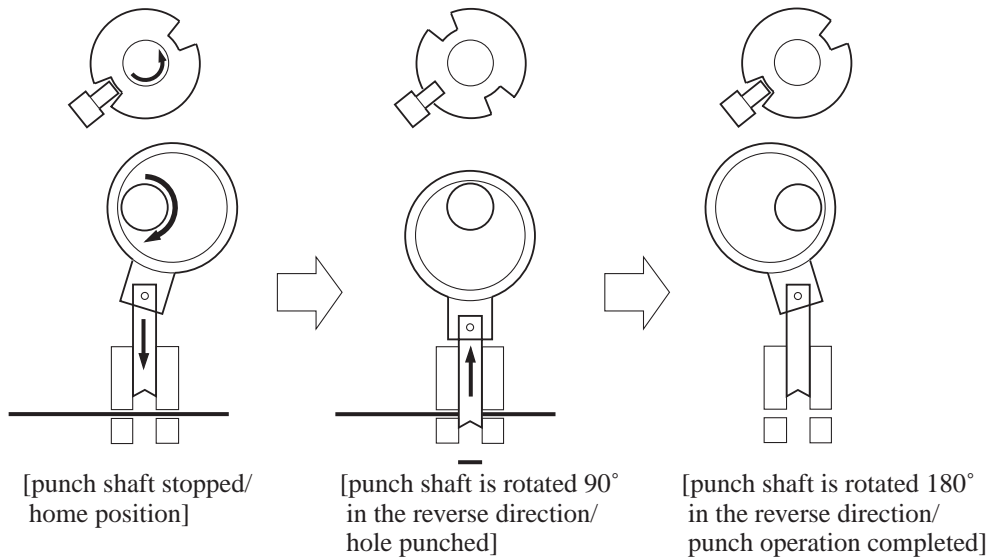

Figure 4-206

When two holes are punched, the 3-hole puncher is fed reciprocally in the escape direction (hole puncher rise direction) as shown below.

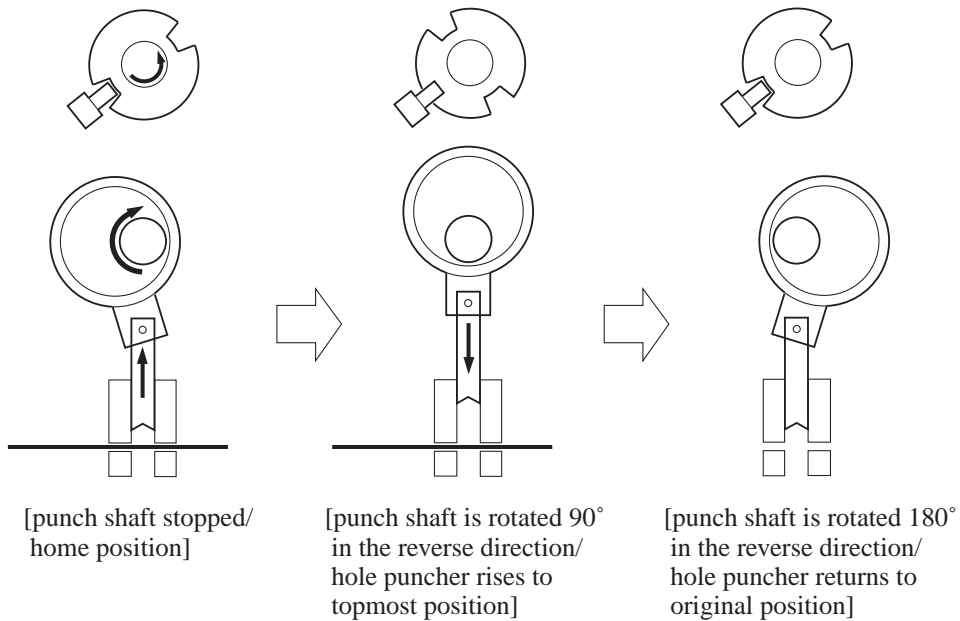

Figure 4-207

C. Horizontal Registration Operation

Horizontal registration drive of the punch slide unit is performed by the horizontal registration motor (M2P). The home position of the punch slide unit is detected by the horizontal registration home position sensor (PI1P). The punch slide unit detects the trailing edge of the paper by the trailing edge sensor (LED5, PTR5) and horizontal registration sensors (LED1 to 4, PTR1 to 4) and is moved to the trailing edge position matched to the paper size.

The following shows horizontal registration operation.

- 1) When the leading edge of the paper from the host machine is detected by the trailing edge sensor (LED5, PTR5) on the puncher unit, the horizontal registration motor (M2P) starts to move the punch slide unit towards the front.

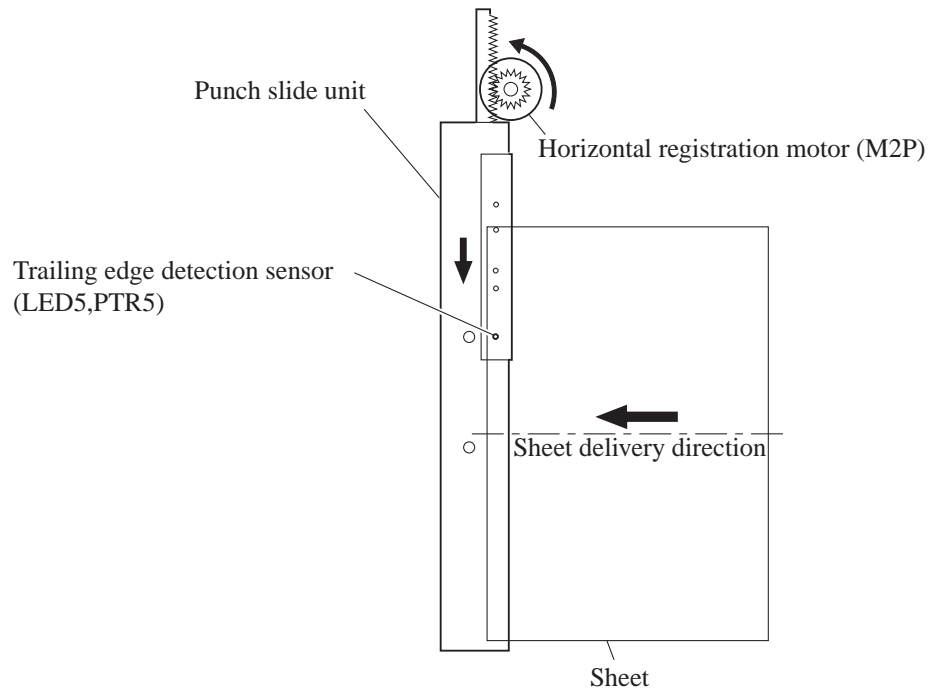

Figure 4-208

- 2) After the horizontal registration sensors (LED1 to 4, PTR1 to 4) detect the edge of the paper at its inner side in keeping with the paper size signals arriving from the host machine, the horizontal registration motor (M2P) drives the punch slide unit to a predetermined position further towards the front, and stops the unit at this position.

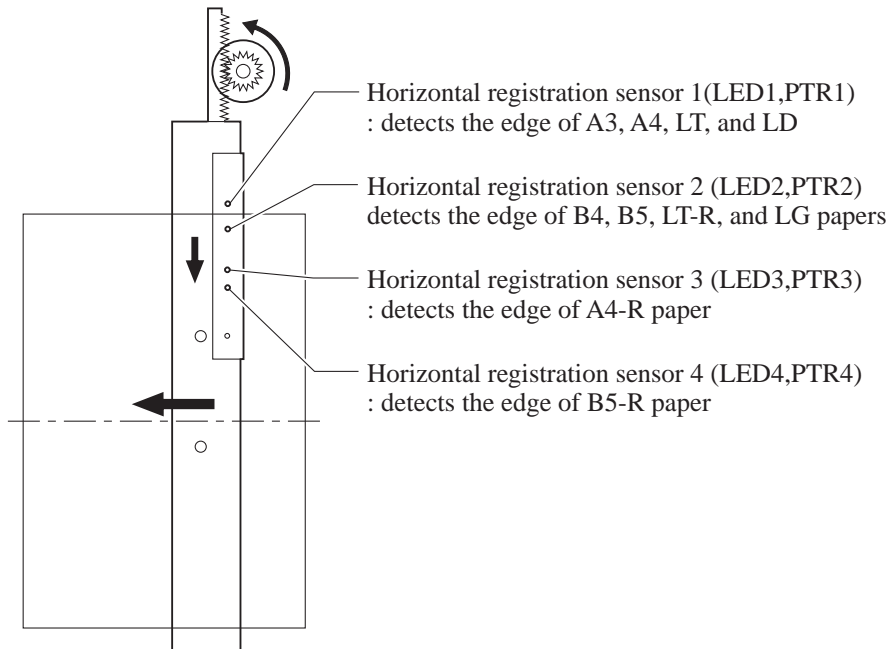

Figure 4-209

- 3) When the trailing edge sensor (LED5, PTR5) detects the trailing edge of the paper, drive of the inlet feed motor (M9) and first feed motor (M1) on the finisher is stopped to stop paper feed. Next, the punch motor (M1P) is driven to punch holes in the paper.

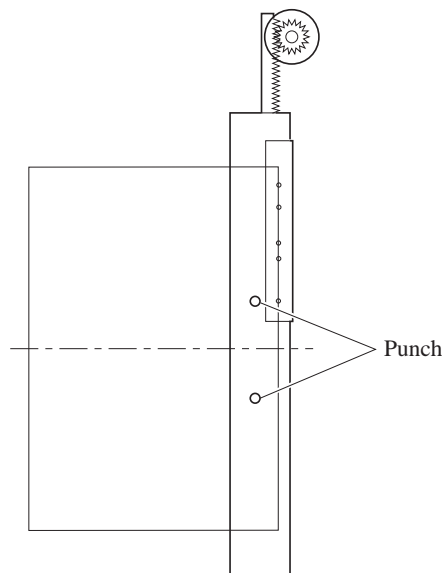

Figure 4-210

- 4) When punching ends, drive of the inlet feed motor (M9) and first feed motor (M1) on the finisher is started, the horizontal registration motor (M2P) is operated in the reverse direction, and the punch slide unit is returned to its home position where it comes to a stop.
- 5) Even if paper to be punched continues to arrive, the punch slide unit returns to its home position for each arriving sheet, and steps 1 to 4 are repeated.

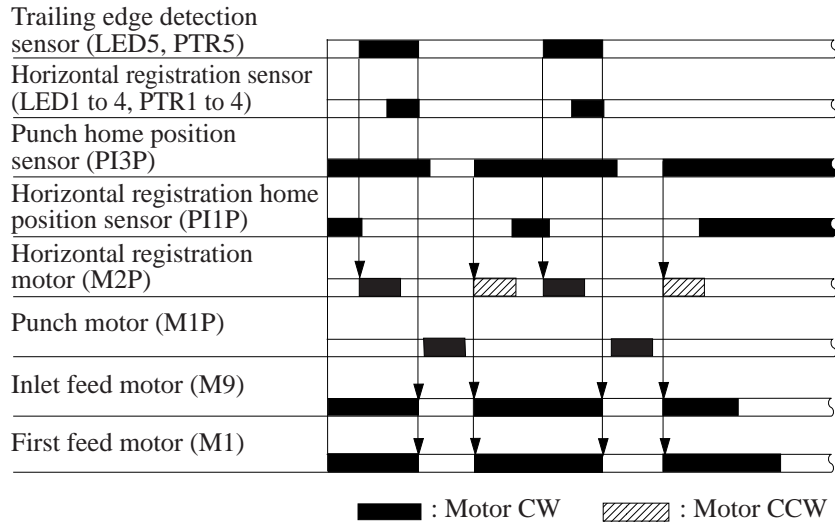

Figure 4-211

III. POWER SUPPLY SYSTEM

1. Outline

24V power and 5V power are supplied from the finisher controller PCB when the power switch on the host machine is turned ON.

24V power is used for driving motors, while 5V power is used for driving sensors and the ICs on the punch driver PCB.

24V power to the motors is not supplied when even either of the two door switches on the puncher unit is open.

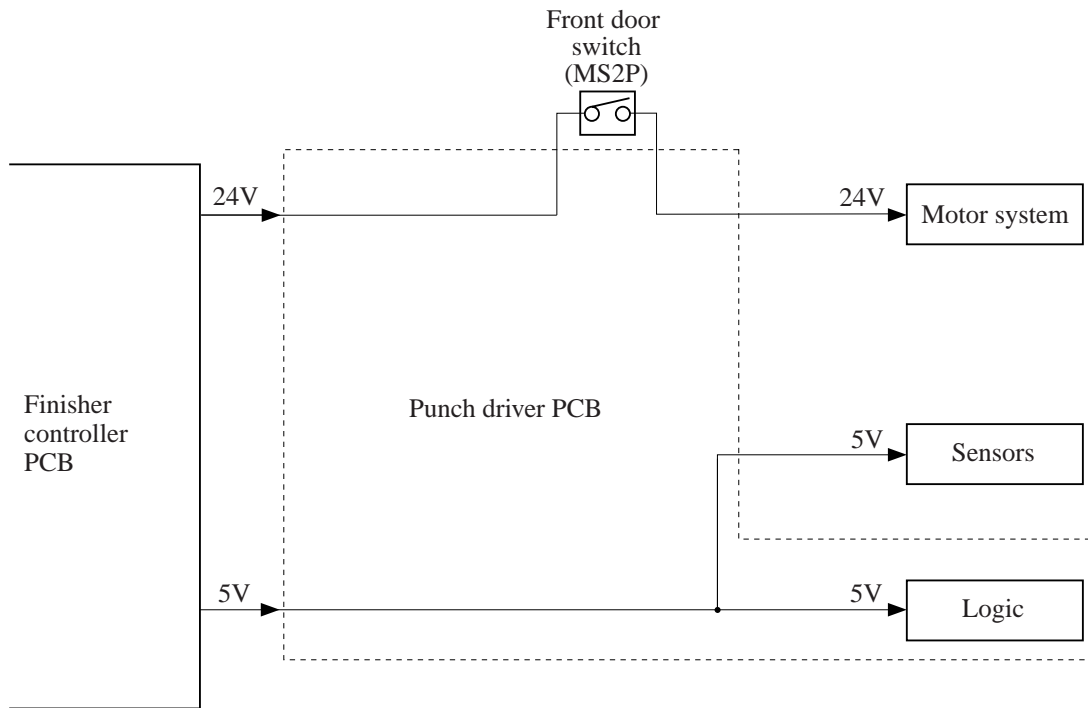

Figure 4-301

2. Protection Function

The 24V power supplies for the punch motor (M1P) and horizontal registration motor (M2P) are equipped with a fuse designed to blow when an overcurrent flows.

CHAPTER 5

MECHANICAL CONSTRUCTION

This chapter describes the mechanical features and operations, and disassembly and assembly procedures.

Be sure to observe the following points when disassembling and assembling the machine:

1. **▲** Before performing disassembly and assembly, be sure to unplug the power plug for safety's sake.
2. Assemble parts by following the disassembly procedure in reverse unless otherwise mentioned.
3. Assemble screws, etc. making sure that their type (length and diameter) and location of use are correct.
4. In principle, do not operate the machine with any parts removed.

I. FINISHER UNIT	5-1	B. SADDLE UNIT	5-22
A. Externals and Controls	5-1	C. PCBs	5-32
B. FEEDING SYSTEM	5-8	III. PUNCHER UNIT (OPTION)	5-33
C. PCBs	5-16	A. Externals and Controls	5-33
II. SADDLE STITCHER UNIT	5-17	B. Puncher Driver System	5-34
A. Externals and Controls	5-17	C. PCBs	5-39

I. FINISHER UNIT

A. Externals and Controls

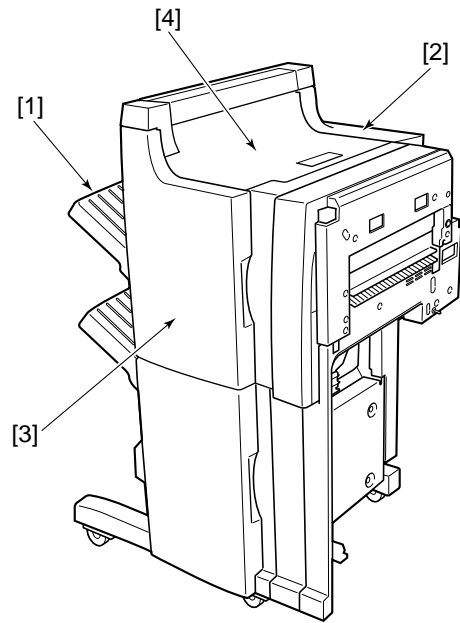

- [1] Tray
 - [2] Rear cover (3)
 - [3] Front door
 - [4] Upper cover assembly
- Figures in parentheses () indicate the number of mounting screws.

Figure 5-101

1. Removing the Front Door Assembly

- 1) Open the front door assembly [1].
- 2) Remove the screw [2] and take out the bushing [3] (center).
- 3) Remove the screw [4] and take out the bushing (top) [5]. Then remove the front door assembly.

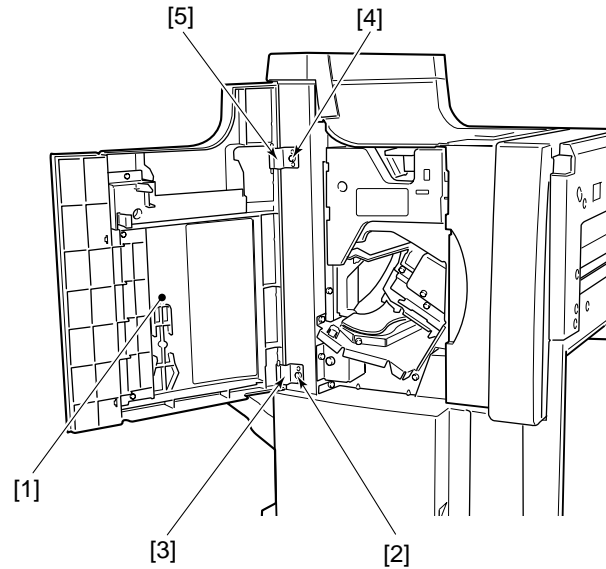
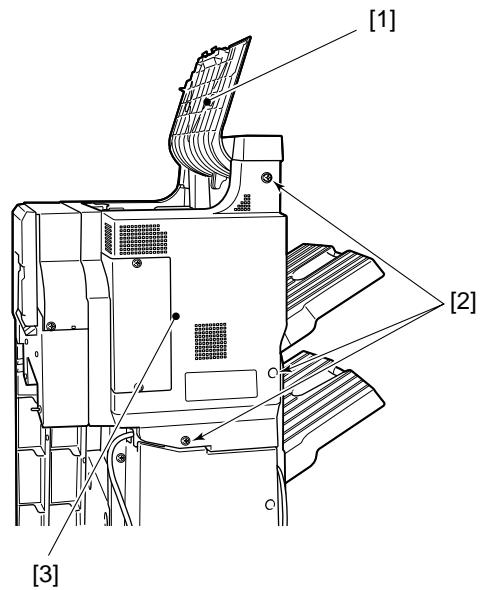

Figure 5-102

2. Removing the Rear Cover

- 1) Open the upper cover assembly [1].
- 2) Remove the three screws [2] and lift the rear cover [3] to take it out.



- [1] Upper cover assembly
- [2] Screws
- [3] Rear cover

Figure 5-103

3. Removing the Upper Cover Assembly

- 1) Open the upper cover assembly [1].
- 2) Remove the two claws [2] and take out the upper cover assembly.

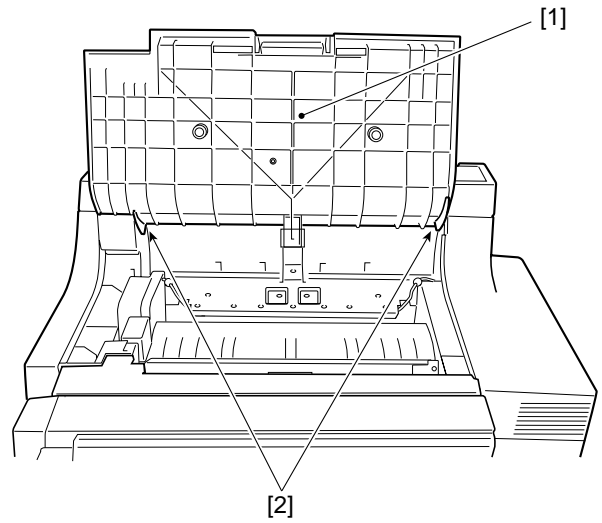

Figure 5-104

4. Removing the Front Cover

- 1) Open the front door assembly [1].
- 2) Remove the screw [2] and take out the front cover [3].

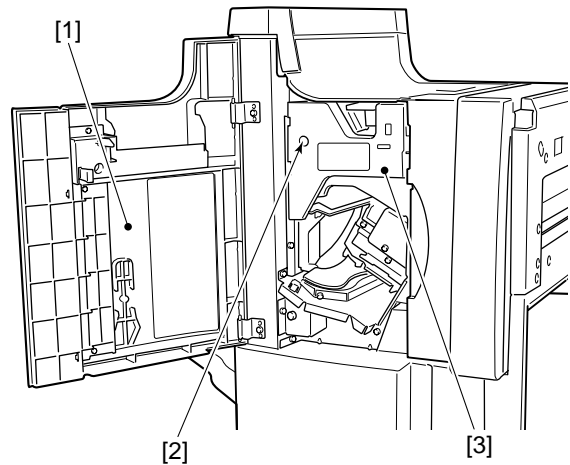

Figure 5-105

5. Removing the Tray Assembly

- 1) Remove the rear cover. (See I-A-2.)
- 2) For the Saddle Finisher, remove the rear lower cover also. (See II-A-2.)
- 3) Disconnect J201 [1] and the grounding wire [2], and release the harness stop [3].

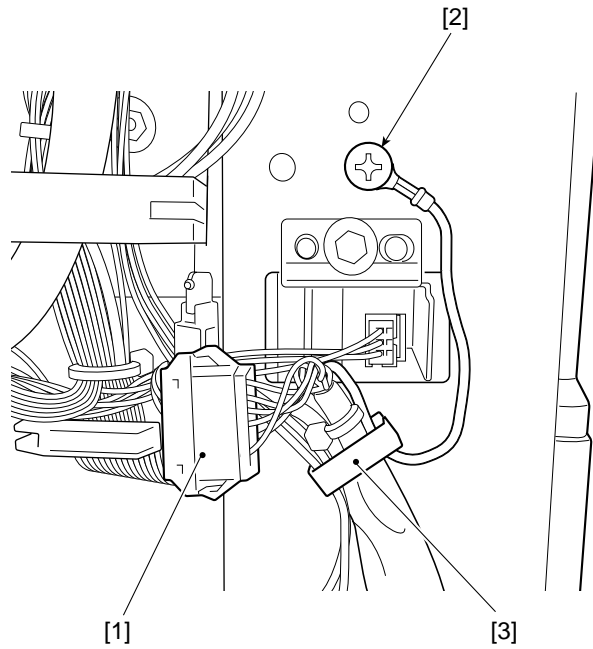

Figure 5-106

- 4) Remove the slide guide [4].
- 5) Remove the end cap (F) [5] and the end cap (R) [6].
- 6) Lift the tray assembly [7] to remove it.

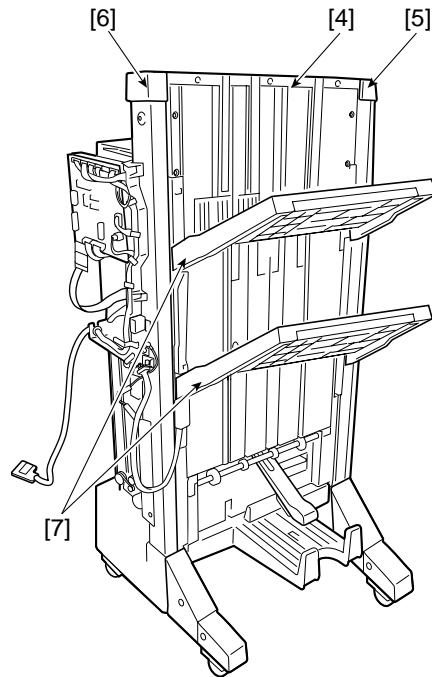

Figure 5-107

Note:

When installing the removed tray assembly back to the finisher assembly, be sure to release the tray lift motor gear clutch [1] with a screwdriver or similar object when inserting it. Take extra care during this operation.

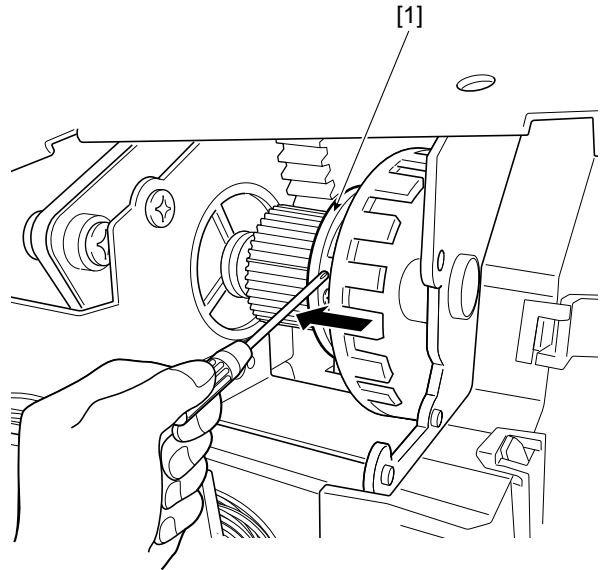

Figure 5-108

6. Removing the Grate-Shaped Upper Guide

- 1) Remove the rear cover. (See I-A-2.)
- 2) Release the tray lift motor gear clutch with a screwdriver or similar object while supporting the tray assembly, and gently lower the tray assembly down to its lowest position. (See Figure 4-108.)
- 3) Remove the slide guide [1].
- 4) Remove the five screws [2] (M4).
- 5) Remove the screw [3] (M3) and take out the grate-shaped upper guide [4].

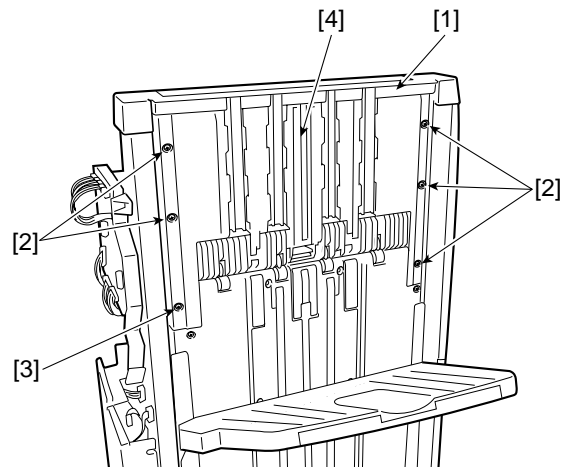

Figure 5-109

7. Removing the Grate-Shaped Lower Guide

- 1) Remove the tray assembly. (See I-A-5.)
- 2) Remove the three screws [1] (M4).
- 3) Remove the three screws [2] (M3) and open the grate-shaped lower guide [3] to the front.

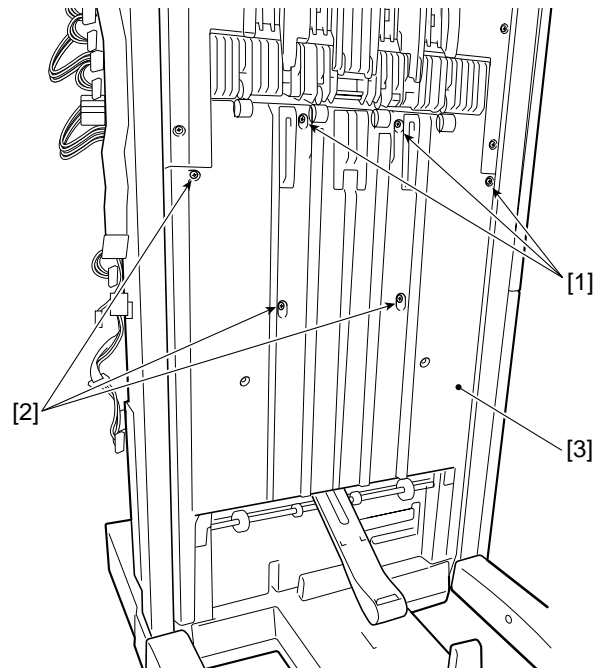

Figure 5-110

- 4) Free the harness [5] from the harness stop [4].
- 5) Disconnect the two connectors [6] and remove the grate-shaped lower guide [3].

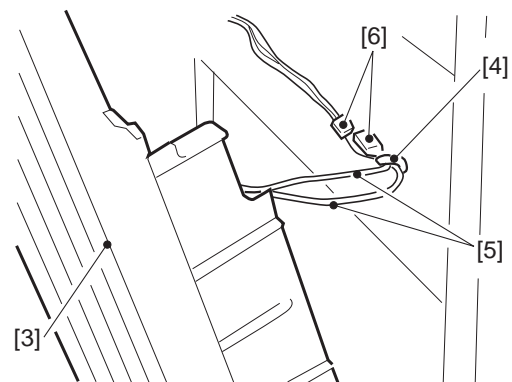

Figure 5-111

8. Removing the Right Guide Assembly

- 1) Remove the four screws [5] to take out the latch unit [4].
- 2) Remove the rear cover. (See I-A-2.)
- 3) Open the front door assembly [1].
- 4) Remove the two screws [2] to take out the right guide assembly [3].

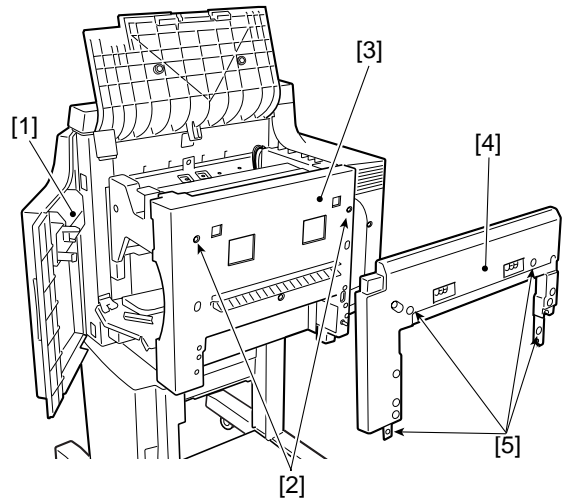

Figure 5-112

B. FEEDING SYSTEM

1. Removing the Swing Unit

- 1) Remove the tray assembly. (See I-A-5.)
- 2) Remove the grate-shaped upper guide. (See I-A-6.)
- 3) Remove the grate-shaped lower guide. (See I-A-7.)
- 4) Remove the harness from the two harness stops [1] and disconnect the four connectors [2].
- 5) Remove the screw [3] and take out the stapler stay holder [4].
- 6) Open the front door.
- 7) Slide the stapler unit to the center position.

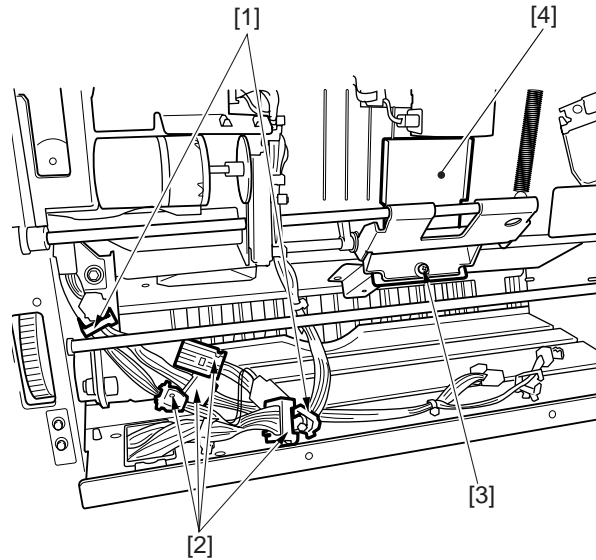

Figure 5-113

- 8) Remove the spring [7] in the front side.

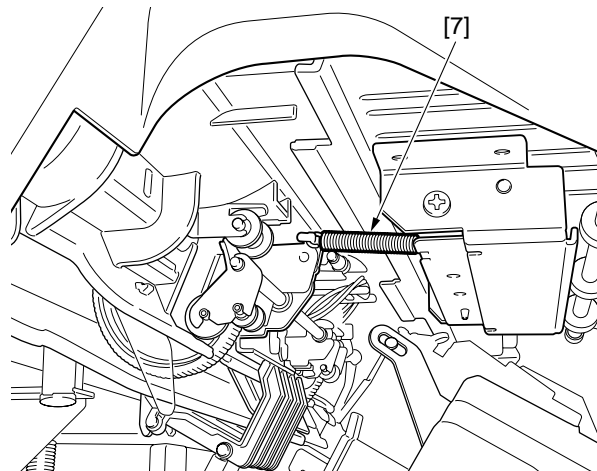

Figure 5-113a

- 9) Remove the three screws [5] and slide out the swing unit [6] towards you. Remove the swing unit.

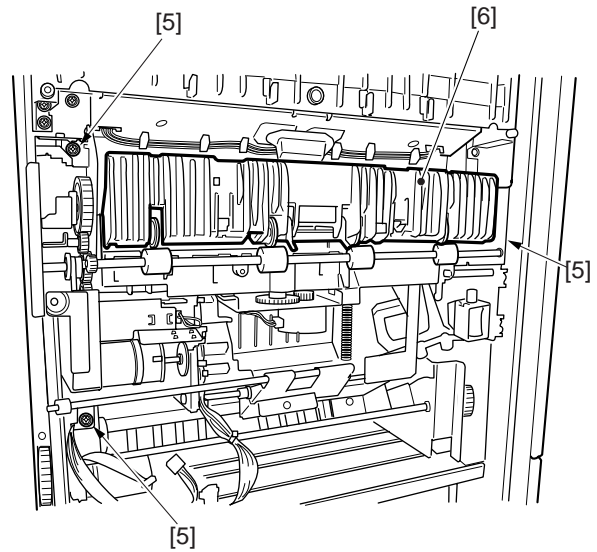

Figure 5-114

2. Removing the Feed Drive Unit

- 1) Remove the finisher controller PCB. (See I-C-1.)
- 2) Remove the harness leads [2] from the two harness stops [1] at the PCB base and disconnect the two connectors [3].

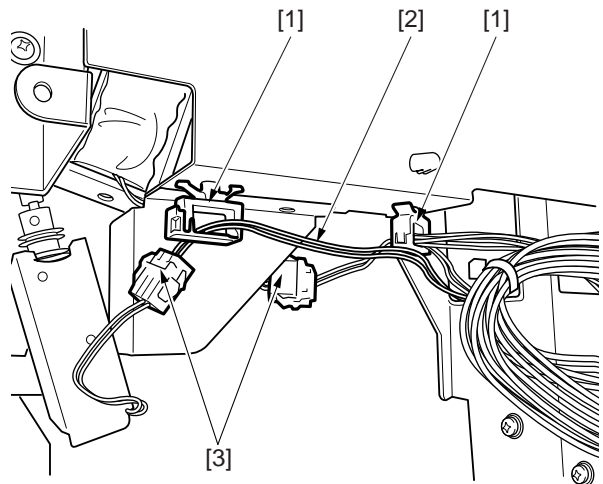

Figure 5-115

- 3) Remove the ground lead [4] and the three screws [5] and pull down the PCB base [6] towards you.

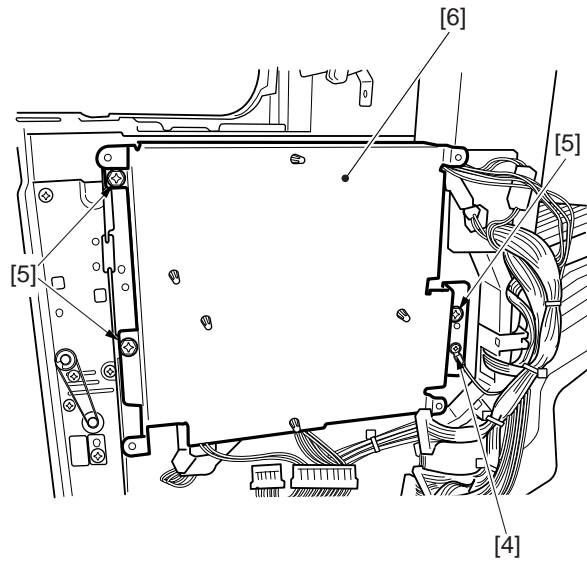

Figure 5-116

- 4) Remove the harness leads [8] from the two edge saddles [7] and remove the PCB base.

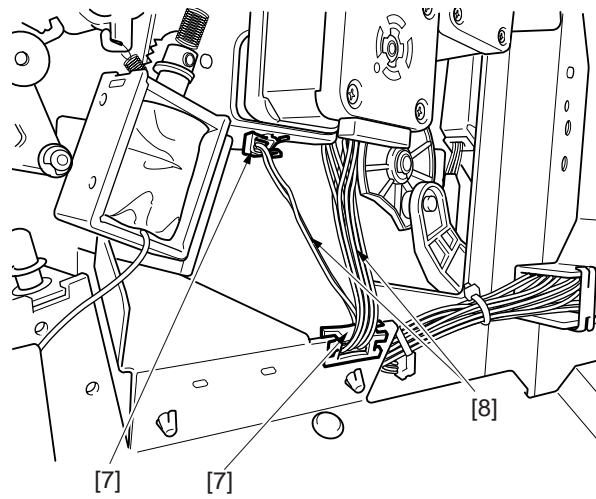

Figure 5-117

- 5) Remove the three screws [9] and take out the feed drive unit [10].

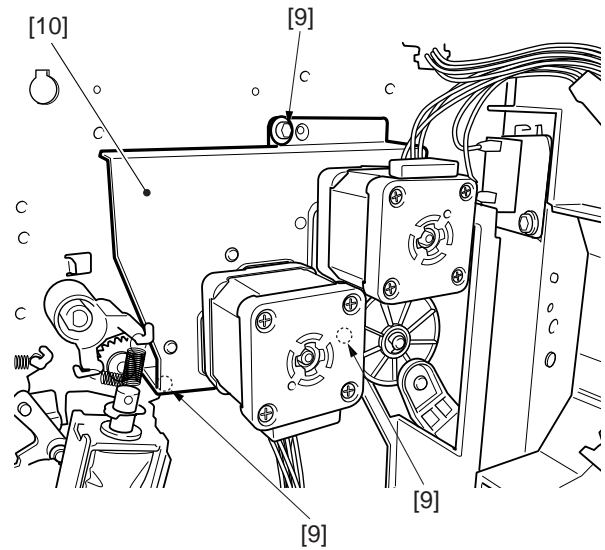

Figure 5-118

Note:

Before reattaching the removed feed drive unit on the finisher unit, loosen the move gear stop screw [11] to relieve the tension, and then fasten the screw after attaching the feed drive unit.

The move gear attachment must be adjusted also when removing and attaching the swing unit.

If you forget to fasten the screw, the gear teeth may disengage, resulting in defective feeding.

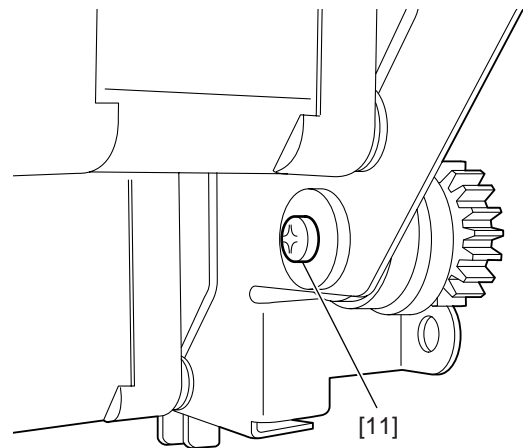

Figure 5-119

3. Removing the Buffer Roller Assembly

- 1) Remove the finisher controller PCB. (See I-C-1.)
- 2) Remove the feed drive unit. (See I-B-2.)
- 3) Take out the screw [1] and remove the guide support plate assembly [2] to slide out the harness leads [3] towards the buffer roller assembly side.

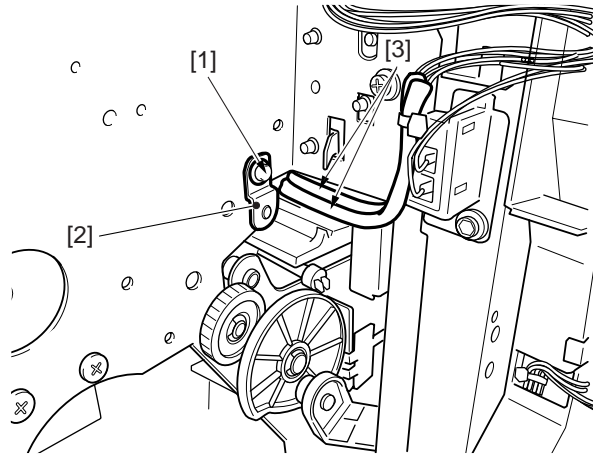

Figure 5-120

- 4) Remove the front cover. (See I-A-4.)
- 5) Remove the screw [4] and take out the guide support plate assembly [5]. Then remove the buffer roller assembly [6].

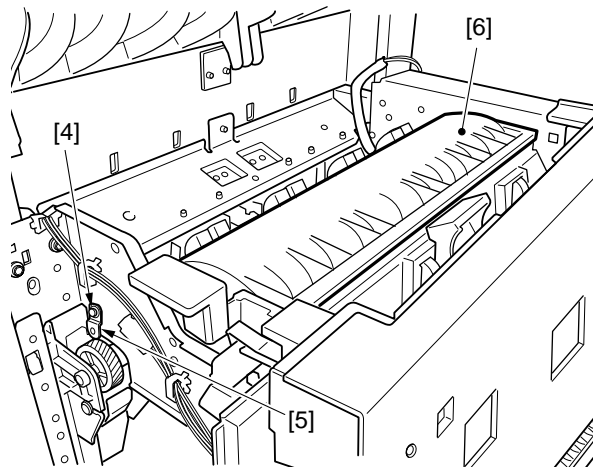

Figure 5-121

4. Removing the Stapler

- 1) Open the front cover, and move the stapler assembly to the front.
- 2) Remove the screw [1], and slide out the stapler assembly [2].
- 3) Remove the right front cover [1] (2 screws).

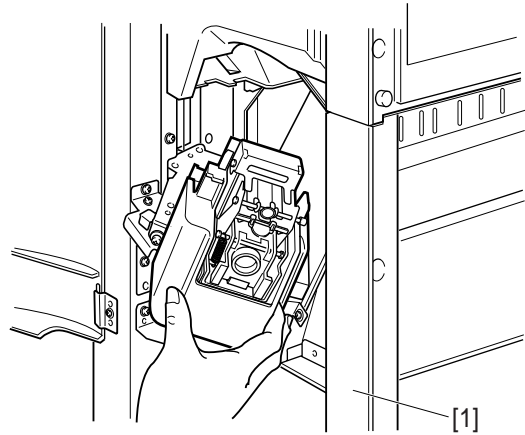

Figure 5-122

- 4) Remove the stepped screws (2 pcs.) which support the stapler unit.

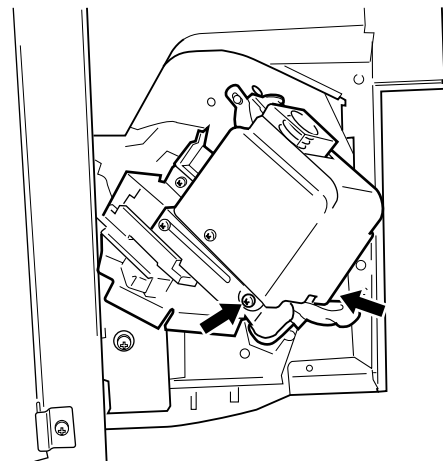

Figure 5-123

- 5) Disconnect the connector [4] of the stapler assembly [3] and the ring terminal of the earth cable.

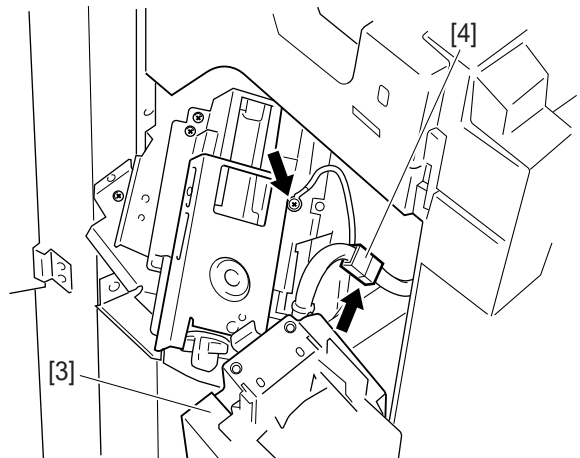

Figure 5-124

- 6) Disconnect the ring terminal [5] of the stapler assembly.

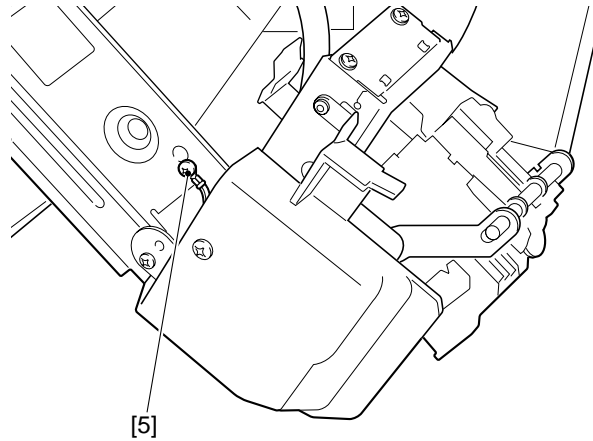

Figure 5-125

- 7) Remove the M4 screws (3 pcs.) which fix the stapler cover.

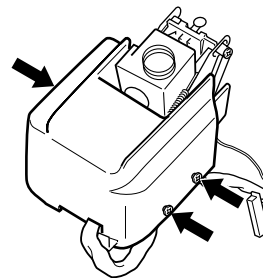

Figure 5-126

- 8) Remove the M4 screws (2 pcs.) which fix the stapler.

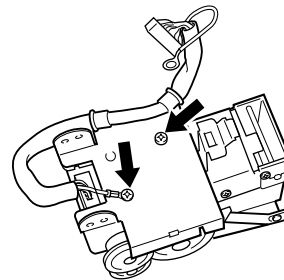

Figure 5-127

5. Removing the Transit Path Assembly

- 1) Remove the two screws [2], and remove the right cover [1].
- 2) Open the upper cover assembly [3], remove the three screws [5], and remove the rear cover [4].

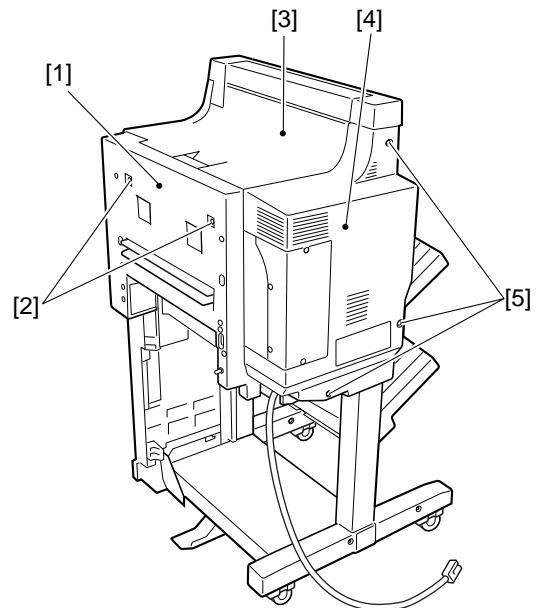
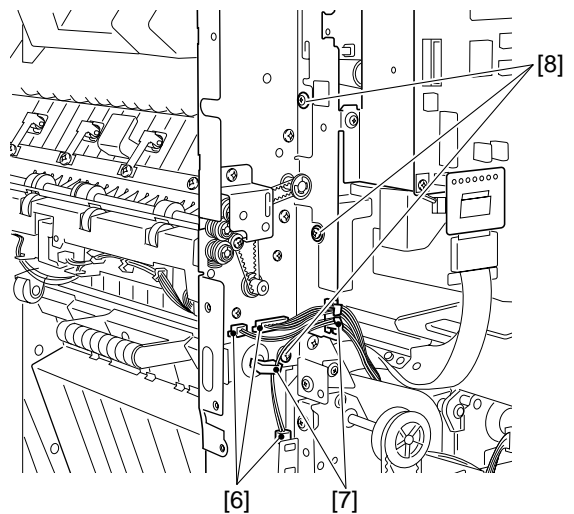
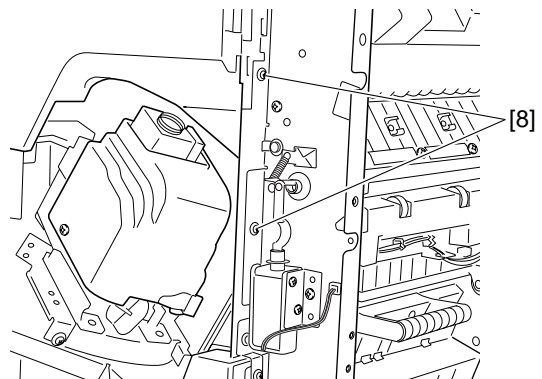

Figure 5-128

- 3) Disconnect the three connectors [6], and free the harness from the two harness stops [7].
- 4) Remove the five screws [8] used to fix the transit path assembly. (two screws in the rear and two in the front)
- 5) Hold the transit path assembly with both hands, and remove it as if to lift it to the front.



Rear side



Front side

Figure 5-129

C. PCBs

1. Removing the Finisher Controller PCB

- 1) Remove the rear cover. (See I-A-2.)
- 2) Disconnect the 16 connectors [1].
- 3) Remove the four screws [2] and take out the finisher controller PCB [3].

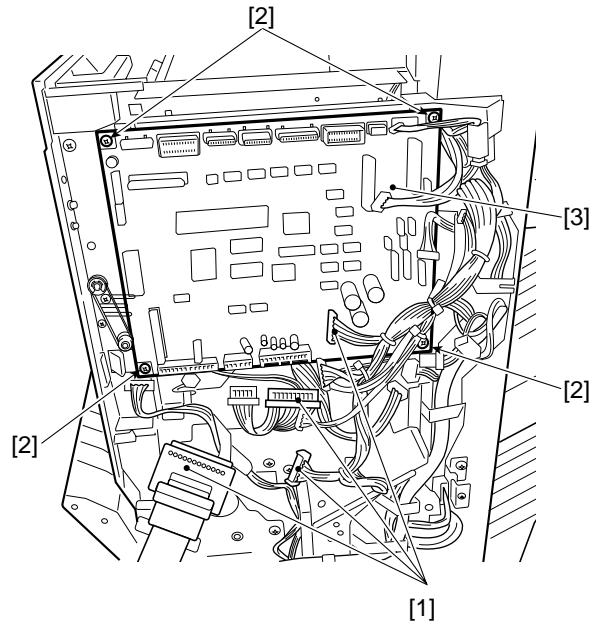
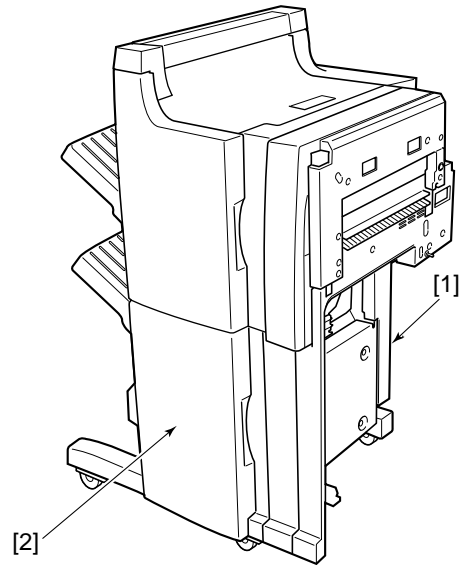

Figure 5-130

II. SADDLE STITCHER UNIT

A. Externals and Controls



[1] Rear lower cover (4)

[2] Front lower door

Figures in parentheses () indicate the number of mounting screws.

Figure 5-201

1. Removing the Front Lower Door Assembly

- 1) Open the front lower door assembly [1].
- 2) Remove the screw [2] and take out the bushing [3]. Then remove the front lower door assembly.

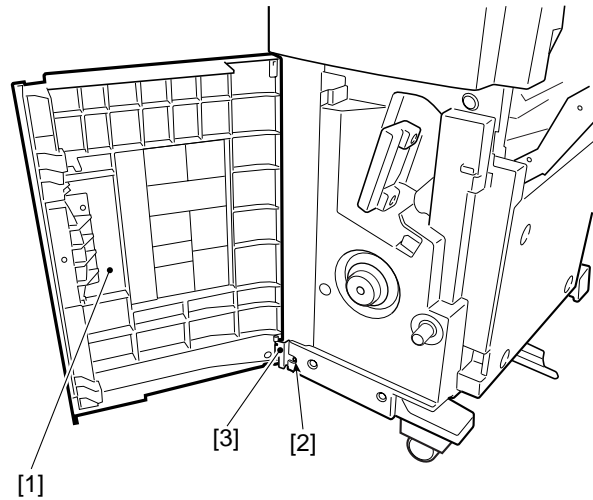

Figure 5-202

2. Removing the Rear Lower Cover

- 1) Remove the four screws [1] and take out the rear lower cover [2].

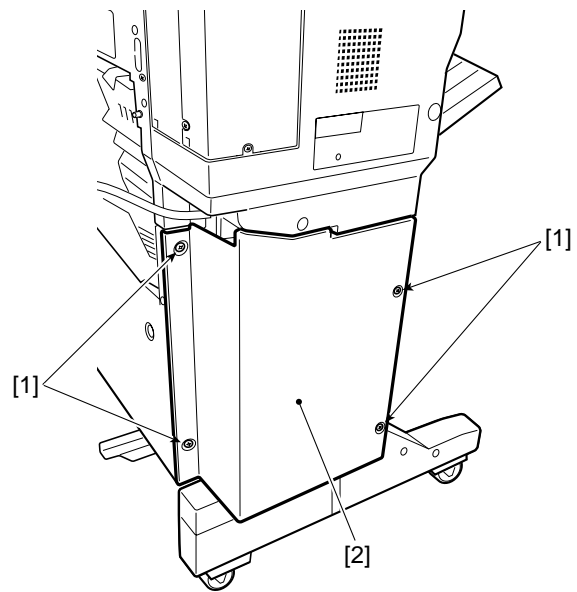

Figure 5-203

3. Removing the Front Inside Cover

- 1) Open the front lower door assembly [1].
- 2) Remove the screw [2] and take out the folding roller knob [3].
- 3) Remove the five screws [4] and take out the front inside cover [5].

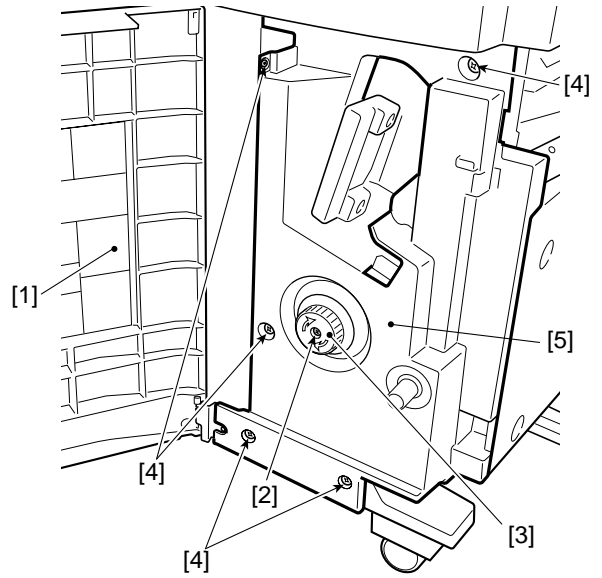

Figure 5-204

4. Removing the Saddle Delivery Tray Assembly

- 1) Lift up the open/close lever [2] of the saddle delivery tray assembly [1] and open the saddle delivery tray assembly.

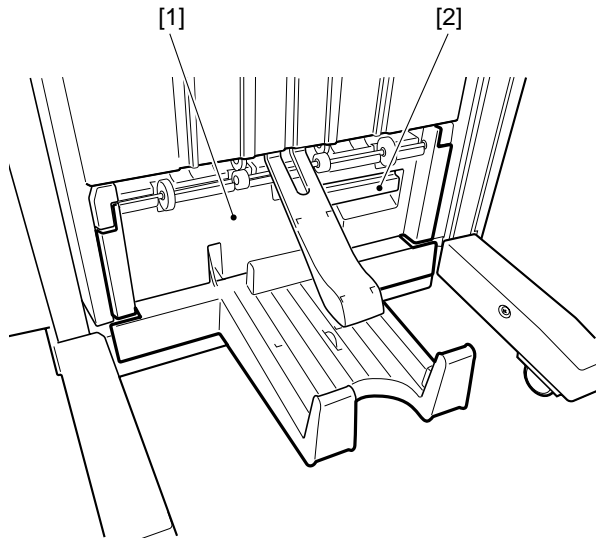

Figure 5-205

- 2) Remove the door shaft [3] in the direction of the arrow and slide out towards the front of the saddle delivery tray assembly [4].

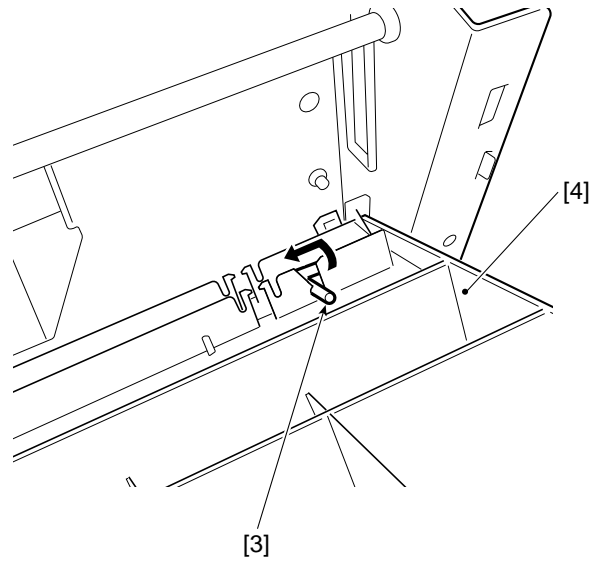

Figure 5-206

- 3) Remove the harness leads from the harness stop [5] and edge saddle [6].
- 4) Disconnect the two connectors [7] and remove the saddle delivery tray assembly [8].

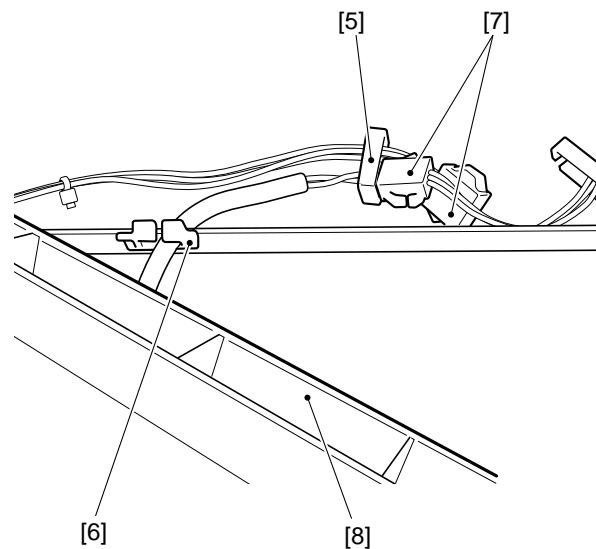

Figure 5-207

5. Removing Upper Delivery Guide Assembly

- 1) Remove the grate-shaped lower guide. (See I-A-7.)
- 2) Remove the two screws [1] and the ground lead [2]. Then remove the upper delivery guide assembly [3].

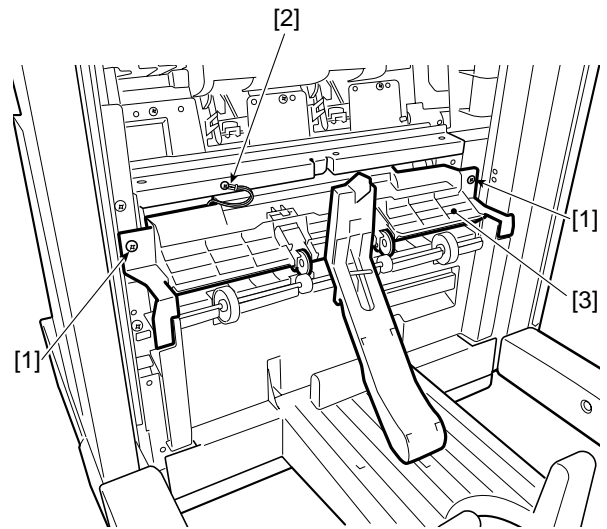

Figure 5-208

6. Removing the PCB Cover

- 1) Remove the four screws [4] and take out the PCB cover [2].

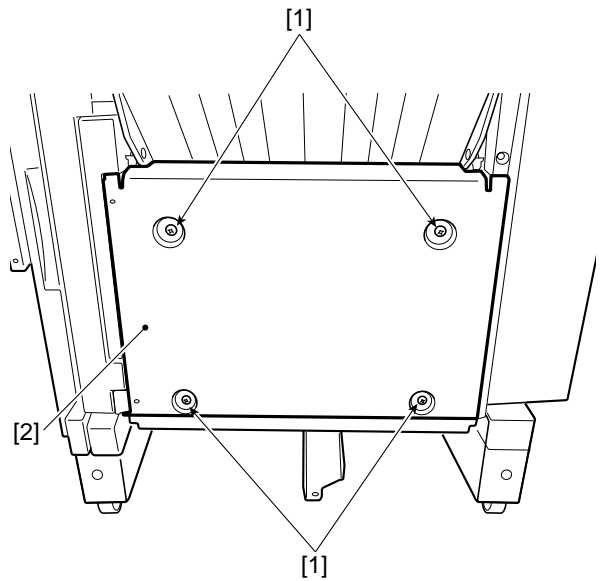

Figure 5-209

B. SADDLE UNIT

1. Removing the Saddle Unit

- 1) Remove the grate-shaped lower guide. (See I-A-7.)
- 2) Remove the right guide assembly. (See I-A-8.)
- 3) Remove the front lower door assembly. (See II-A-1.)
- 4) Remove the rear lower cover. (See II-A-2.)
- 5) Remove the front inside cover. (See II-A-3.)
- 6) Remove the saddle delivery tray assembly. (See II-A-4.)
- 7) Remove the upper delivery guide. (See II-A-5.)
- 8) Remove the PCB cover. (See II-A-6.)
- 9) Disconnect two connectors [1] and remove the two screws [2].

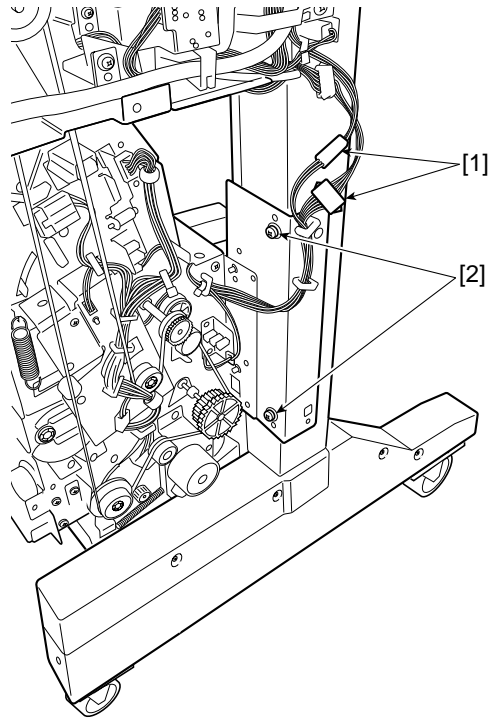

Figure 5-210

- 10) Remove harness stop [3] and the harness lead [4].

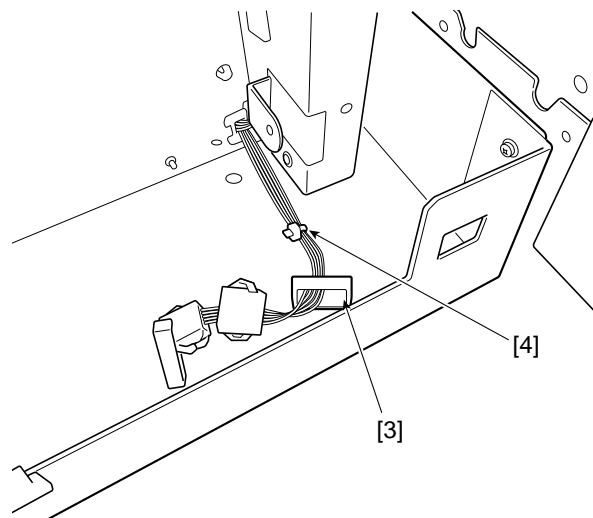

Figure 5-211

11) Remove the screw [5].

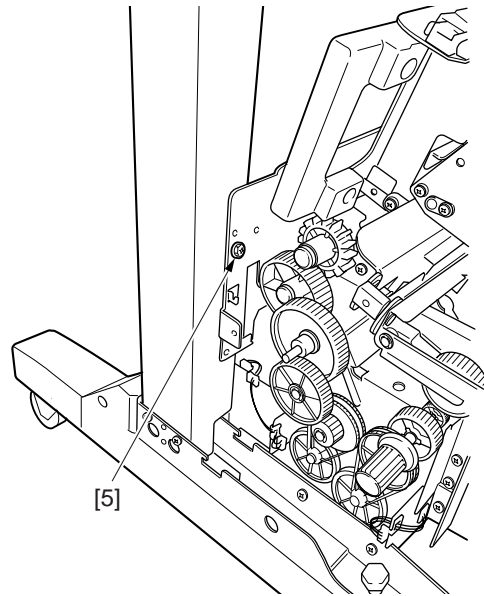

Figure 5-212

12) Remove the two screws [6] and take out the saddle stitcher unit [7] by moving it in the pick-up direction.

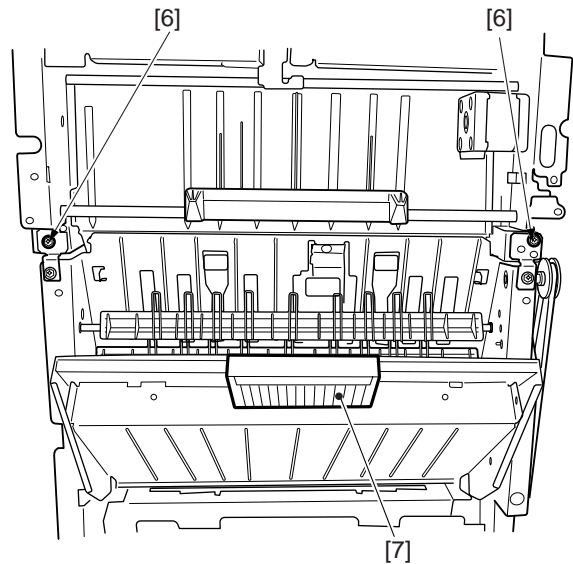

Figure 5-213

Note:

When removing the saddle unit from the finisher unit body, prevent the timing belt [8] from catching on the communications cable bracket [9].

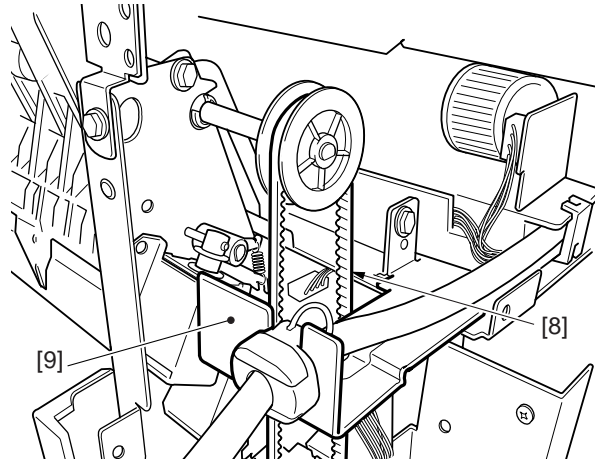

Figure 5-214

2. Removing the Paper Folding Roller

- 1) Remove the front lower door assembly. (See II-A-1.)
- 2) Remove the front inside cover. (See II-A-3.)
- 3) Remove the upper delivery guide. (See II-A-5.)
- 4) Remove the PCB cover. (See II-A-6.)
- 5) Disconnect the two connectors [1].

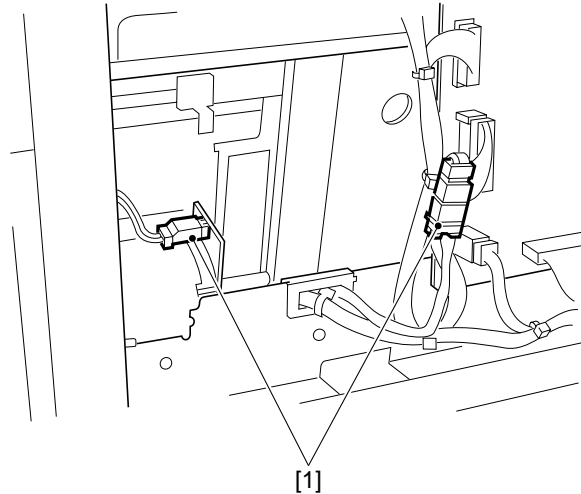

Figure 5-215

- 6) Disconnect two connectors [2], remove the three screws [3], and take out the paper pushing motor mount [4].

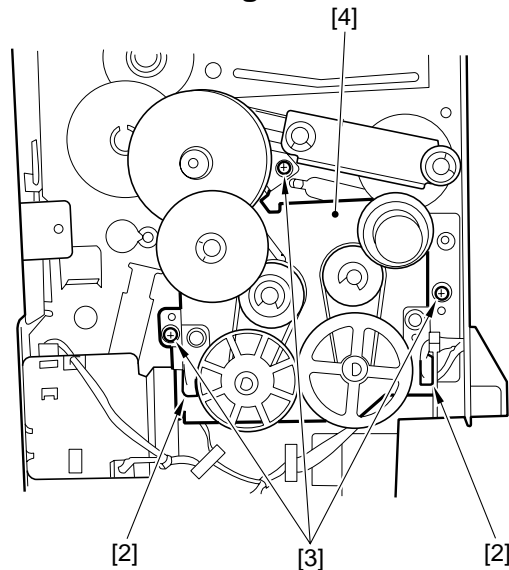

Figure 5-216

- 7) Remove the tension springs (front [5], rear [6]).

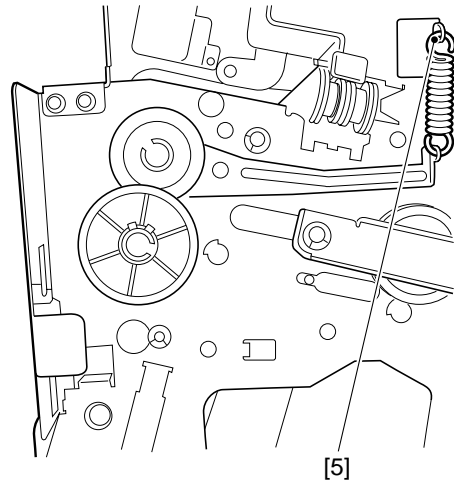

Figure 5-217

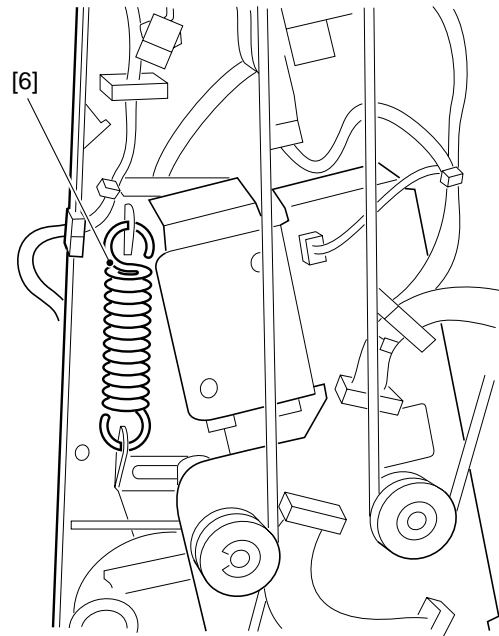

Figure 5-218

- 8) Remove the two C-rings [7] and take out the sensor flag [8] and two bearings [9] at the rear.

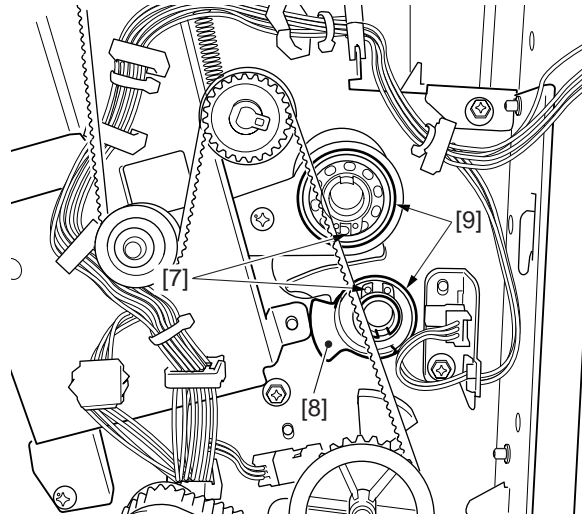

Figure 5-219

- 9) Remove the two C-rings [10] and take out the two gears [11] at the front.

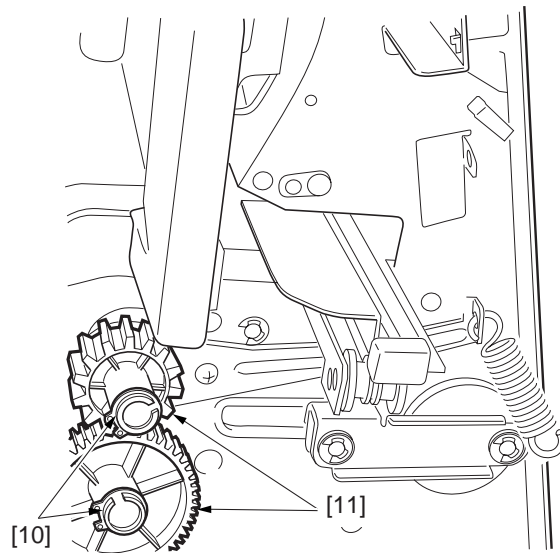

Figure 5-220

10) Remove the two bearings [12].

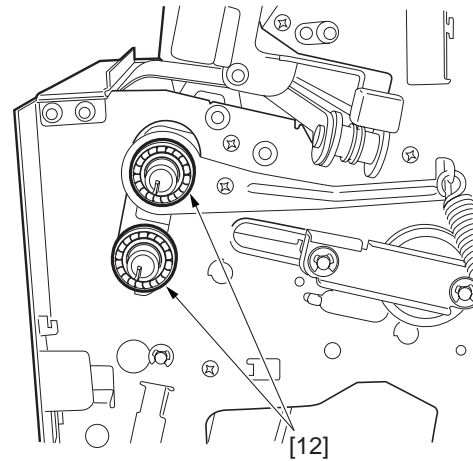

Figure 5-221

- 11) Open the saddle delivery tray assembly [13].
- 12) Remove the two screws [14] and take out the two alignment plates [15].
- 13) Slide the paper folding roller [16] to the front and pull it out in the delivery direction.

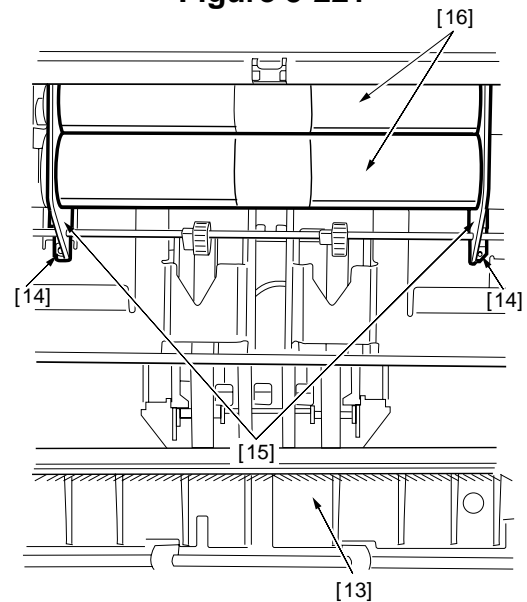

Figure 5-222

3. Installing the Paper Folding Roller

- 1) Attach the gear [2] so that the grooved section [1] on the gear is facing the grooved section [1] on the paper folding roller to align the phases.

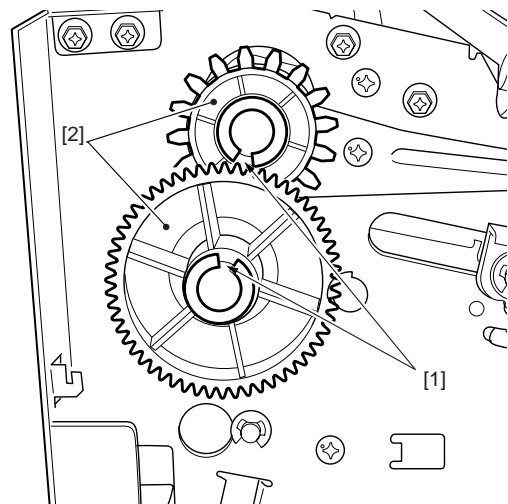

Figure 5-223

4. Removing the Stitcher Mount Unit

- 1) Remove the front inside cover. (See II-A-3.)
- 2) Remove the E-ring [1] and take out the roll [2] and the shaft [3].

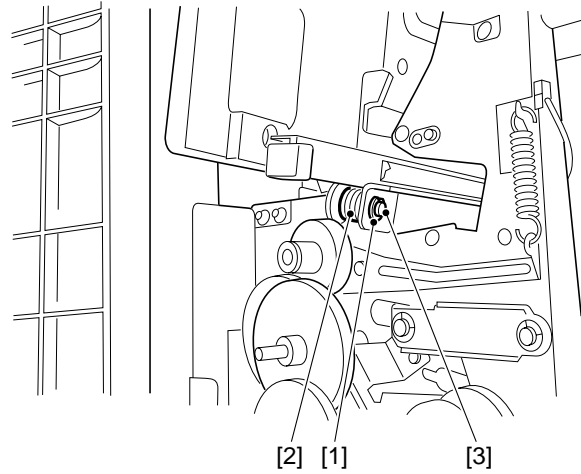

Figure 5-224

- 3) Pull out the stitcher mount unit [4] to the front.

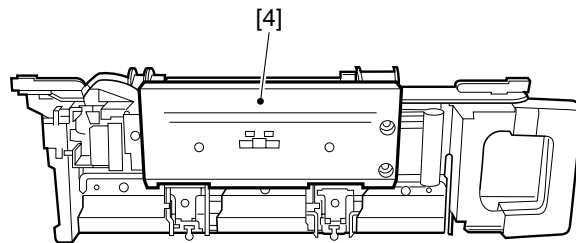

Figure 5-225

5. Adjusting the Stitcher Position

- 1) Remove the front lower door. (See II-A-1.)
- 2) Remove the front inside cover. (See II-A-3.)
- 3) Open the front door assembly.
- 4) Pull out the stitcher mount unit to the front. Then extract the stitcher towards you and then pull the stitcher down.
- 5) Remove the three screws [1] and take out the stitcher mount unit cover [2].

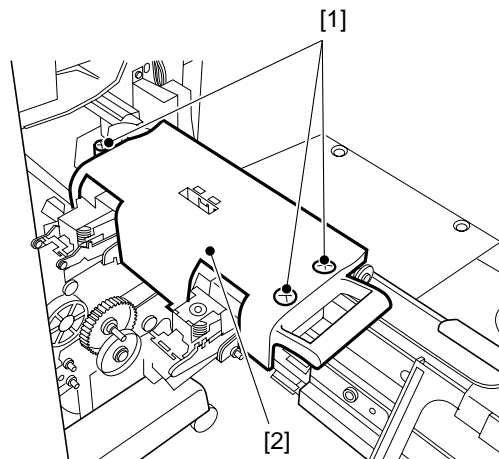

Figure 5-226

- 6) Remove the stitcher positioning tool [3] from the back of the cover.

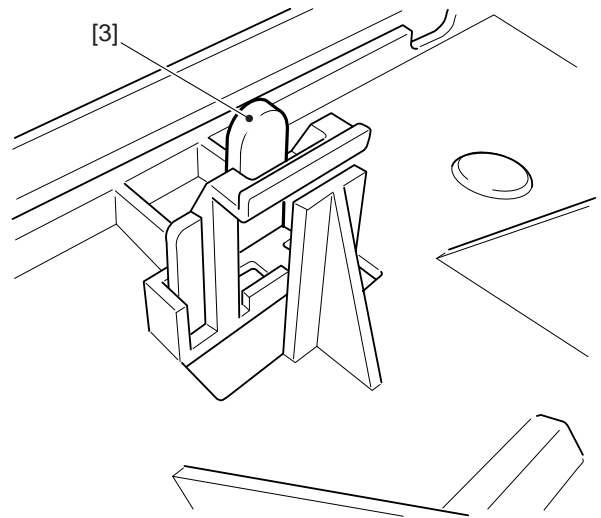

Figure 5-227

- 7) If you must adjust the front stitcher, remove the center guide plate [5] and front guide plate [4] (one screw each). If you must adjust the rear stitcher, remove the center guide plate [5] and the rear guide plate [6] (one screw each).

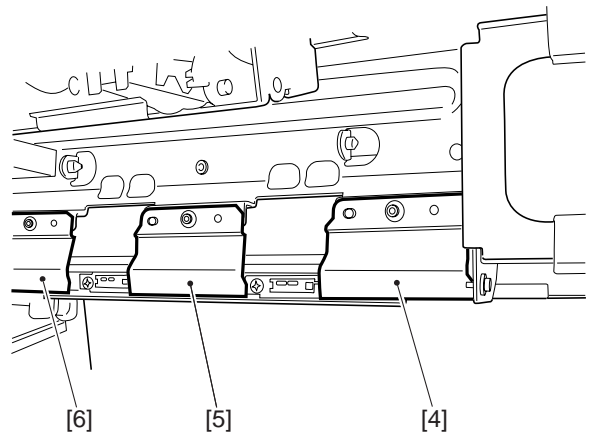

Figure 5-228

- 8) If you must adjust the front stitcher, loosen the two screws [8] on the stitcher mount [7]. If you must adjust the rear stitcher, loosen the two screws [9].

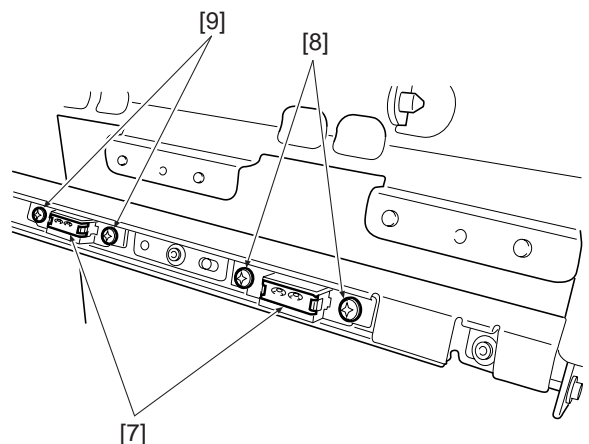

Figure 5-229

- 9) Insert the tool [10] into the staple slot of the stitcher [9].

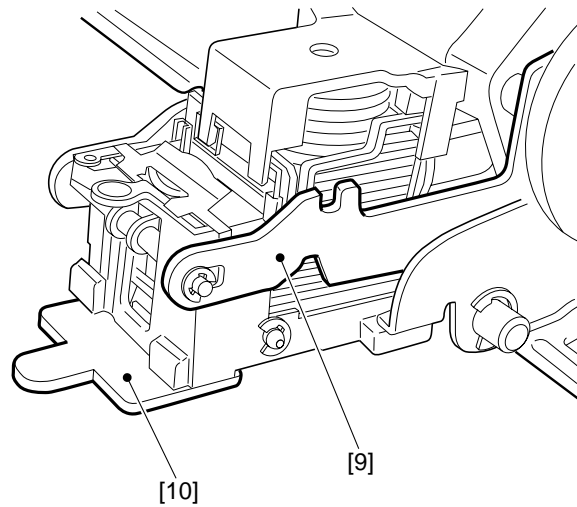

Figure 5-230

- 10) Shift down the stitcher and turn the stitcher gear so that the boss on the tool [11] and the recess of the mount match. Then tighten the screws [12] on the mount to fix the two in place.

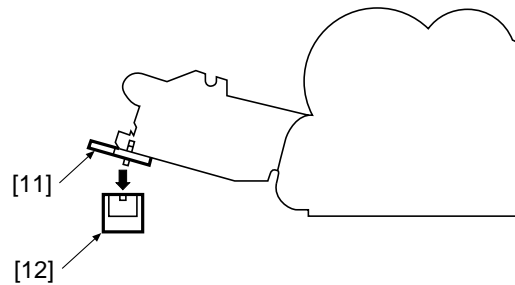

Figure 5-231

6. Removing the Positioning Plate Unit

- 1) Remove the saddle stitcher controller PCB. (See II-C-1.)
- 2) Disconnect the two connectors [1], take out the three harness stops [2], and remove the harness leads [3] from the two edge saddles [4].
- 3) Take out the two screws [5], slide the positioning plate unit [6] once towards the front and remove from the rear side.

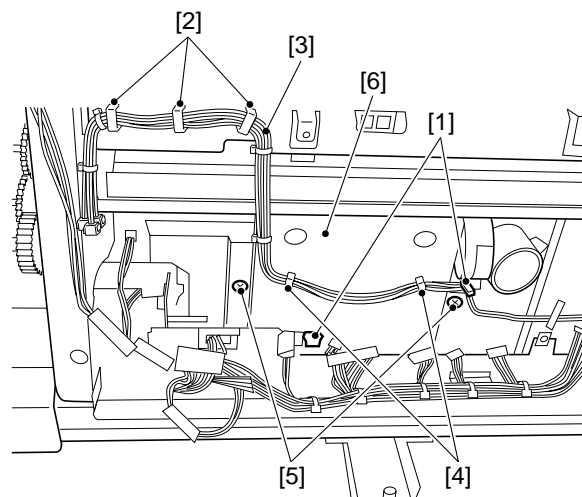

Figure 5-232

7. Removing the No.1 and No.2 Paper Deflecting Plates

- 1) Remove the rear cover. (See I-A-2.)
- 2) Remove the lower rear cover. (See II-A-2.)
- 3) Remove the claw [1] of the No.1 deflecting plate bushing and pull out the No.1 deflecting plate shaft [2] toward the rear. (The procedure is the same for the No.2 paper deflecting plate.)

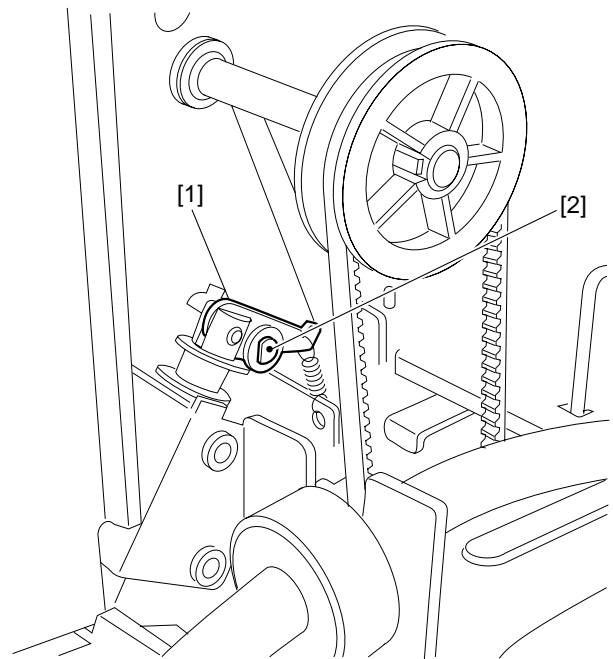

Figure 5-233

- 4) After detaching the front shaft of the No.1 paper deflecting plate [3] from the front side plate, remove the No.1 paper deflecting plate.

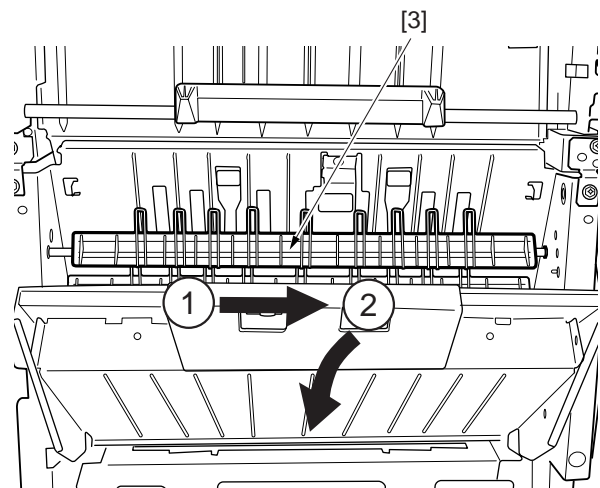

Figure 5-234

C. PCBs

1. Removing the Saddle Stitcher Controller PCB

- 1) Remove the PCB cover. (See II-A-6.)
- 2) Remove the four screws [1] and 14 connectors [2] and take out the saddle stitcher controller PCB [3].

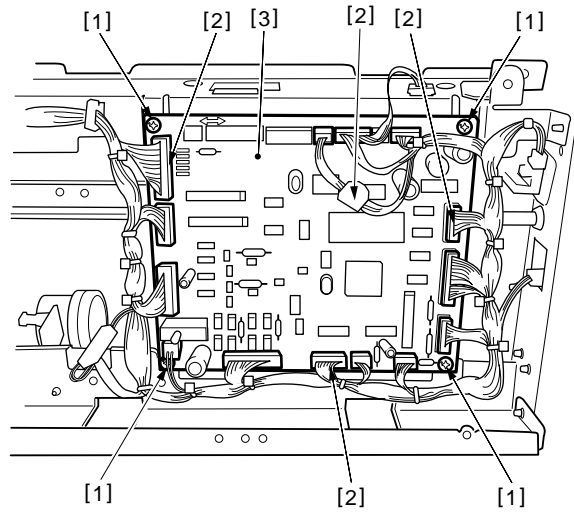
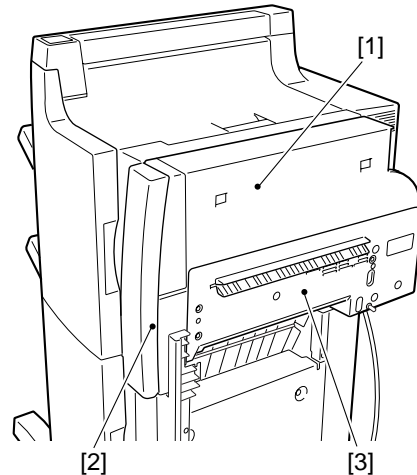

Figure 5-235

III. PUNCHER UNIT (OPTION)

A. Externals and Controls



- [1] Upper cover (3)
 - [2] Front door
 - [3] Right guide assembly (4)
- Figures in parentheses () indicate the number of mounting screws.

Figure 5-301

1. Removing the Right Guide Assembly

- 1) Remove the two screws [3] and take out the latch unit.
- 2) Remove the four screws [1] and take out the right guide assembly [2].

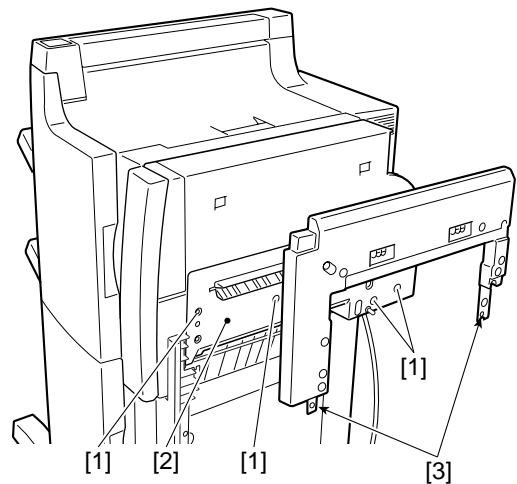

Figure 5-302

2. Removing the Upper Cover

- 1) Remove the right guide assembly (See III-A-1).
- 2) Open the front door [1], remove the three screws [2], and take off the upper cover [3].

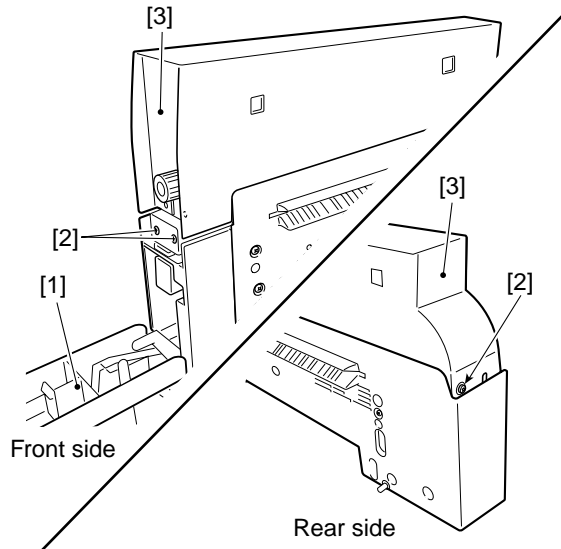

Figure 5-303

B. Puncher Driver System

1. Removing the Punch Motor

- 1) Remove the upper cover. (See III-A-2.)
- 2) Disconnect the connector [1].
- 3) Remove the two screws [2] and take out the punch motor [3].

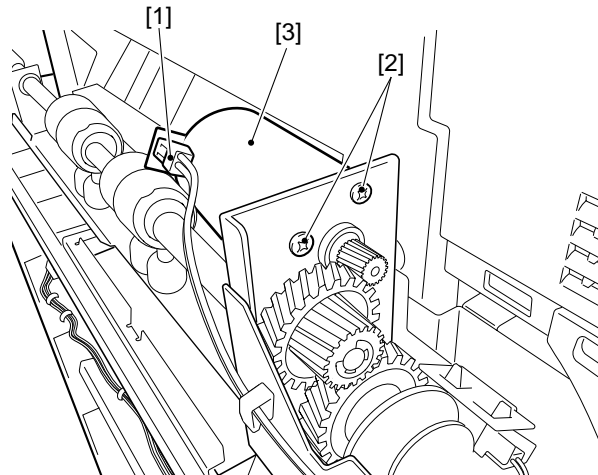

Figure 5-304

2. Removing the Horizontal Registration Motor

- 1) Remove the right guide assembly. (See III-A-1.)
- 2) Disconnect the connector [1].
- 3) Remove the two screws [2] and slide the horizontal registration motor [3] in the direction of the arrow.

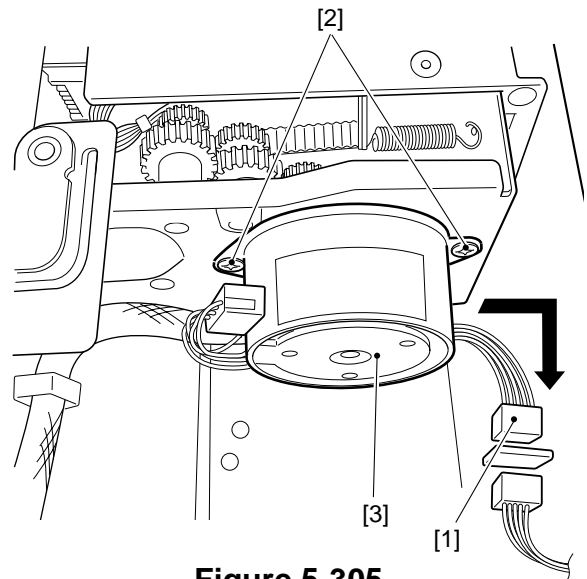

Figure 5-305

3. Removing the Punch Unit

- 1) Remove the right guide assembly. (See III-A-1.)
- 2) Remove the three connectors [1].
- 3) Remove the wire harness [3] from the three wire-harness clamps [2].
- 4) Remove the wire-harness band [3a].

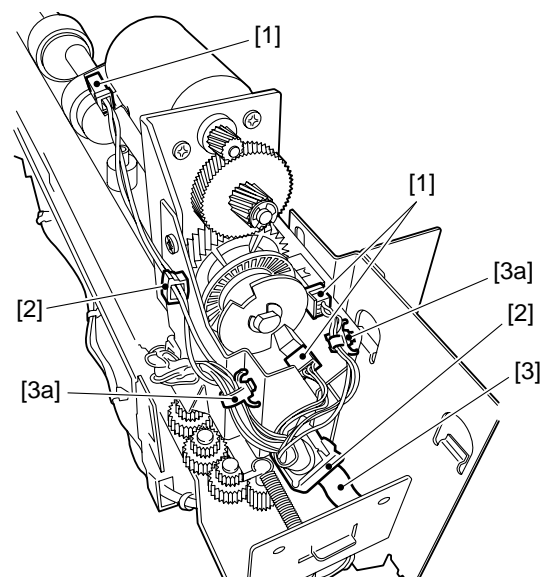

Figure 5-306

- 5) Remove the upper inlet guide [3b] (three screws).

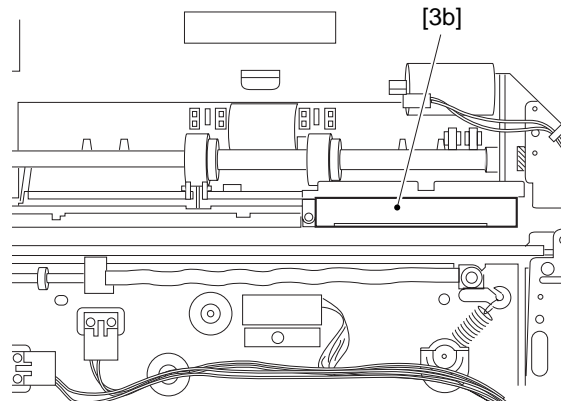

Figure 5-306a

- 6) Remove the connector.
- 7) Remove the E-ring [4] and the puncher spring [5].

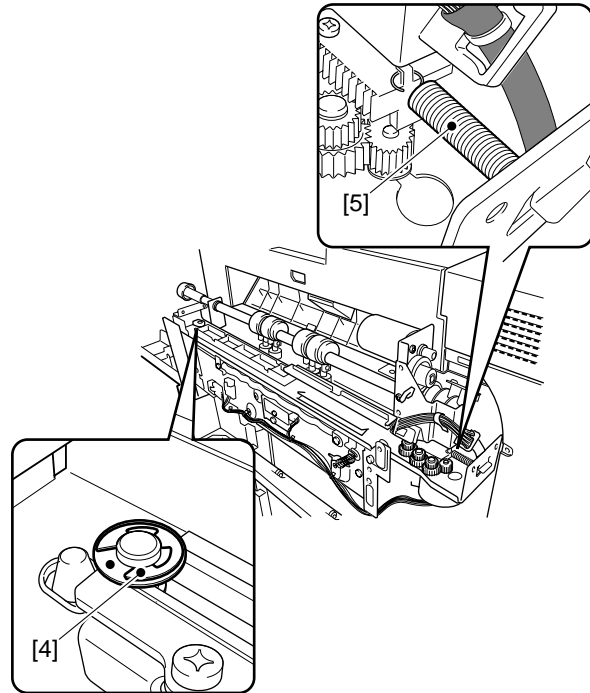

Figure 5-307

- 8) Turn the gear [6] in the direction of the arrow and move the punch unit section [7] to the front side.

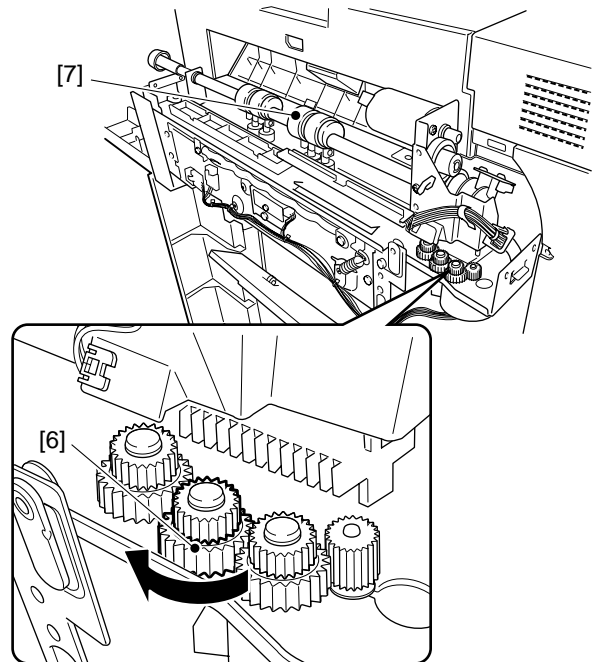

Figure 5-308

- 9) Disconnect the connector [8] and remove the screw [9]. Then take out the horizontal registration sensor [10].

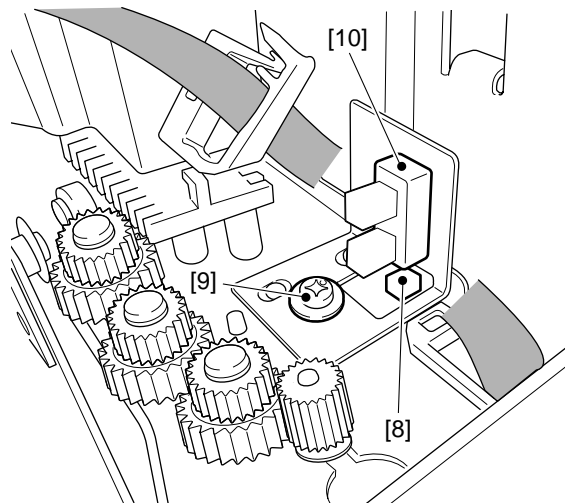

Figure 5-309

- 10) Turn the gear [6] in the direction of the arrow and move the punch unit section [7] to the inner side.

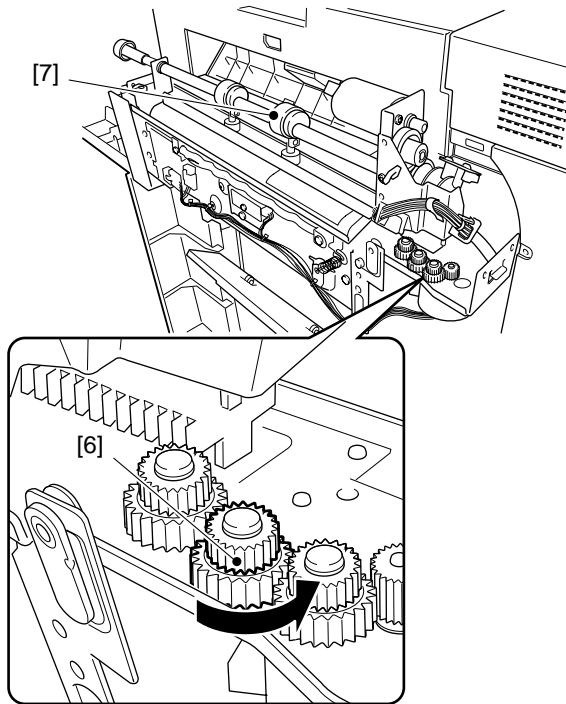

Figure 5-310

- 11) Lift up the front side of the punch unit section [18] first, then move it in the direction of the arrow to remove the punch unit section [18].

Caution:

When removing the punch slide unit, the unit sometimes flies up.

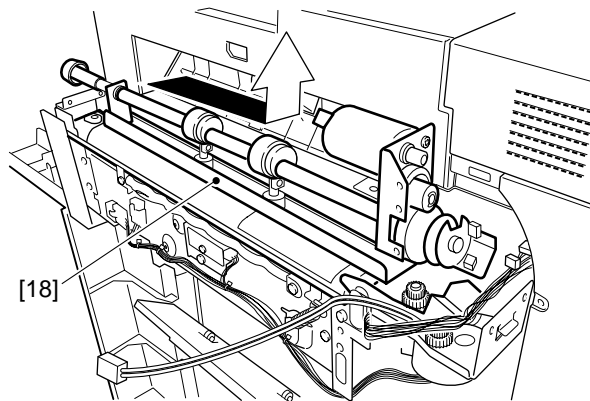

Figure 5-311

C. PCBs

1. Removing the LED PCB

- 1) Remove the punch unit assembly. (See III-B-3.)
- 2) Remove the screw [1] and the LED PCB [2].

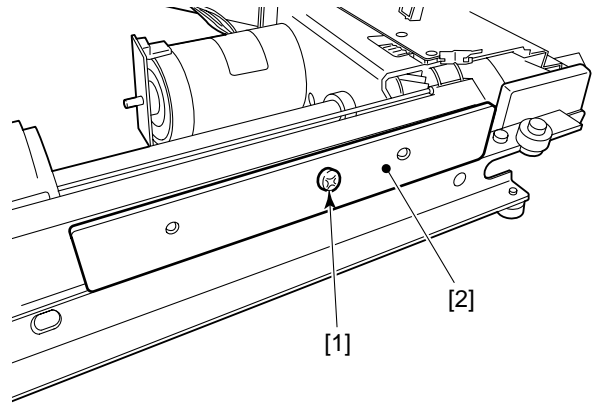

Figure 5-312

2. Removing the Photosensor PCB

- 1) Remove the upper cover. (See III-A-2.)
- 2) Remove the screw [1] and take out the sensor bracket [2].
- 3) Disconnect the connector [3] and remove the photosensor PCB [4].

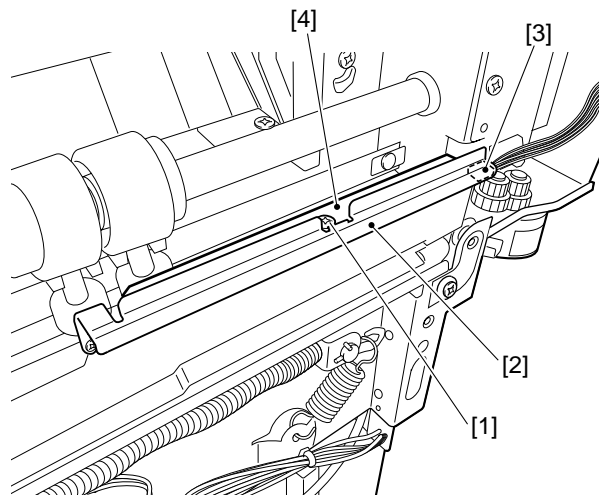

Figure 5-313

3. Removing the Scrap-Full Detector PCB Unit

- 1) Remove the right guide assembly. (See III-A-1.)
- 2) Remove the screw [1], disconnect the connector [2], and take out the scrap-full detector PCB unit [3].

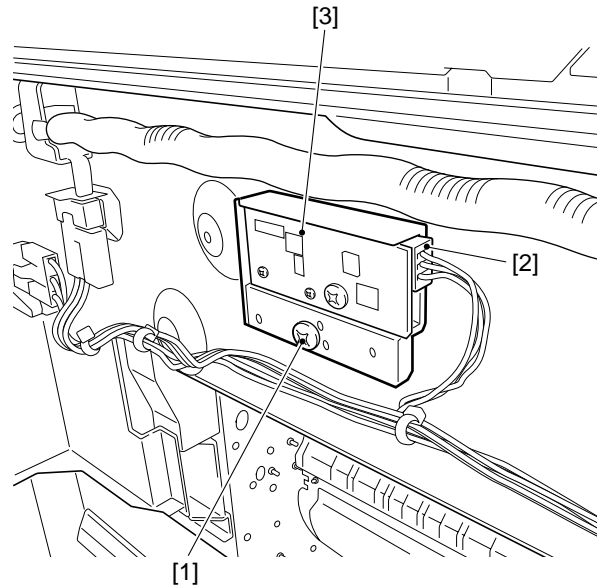

Figure 5-314

4. Removing the Punch Driver PCB

- 1) Remove the puncher unit from the finisher.
- 2) Remove the four screws [1], disconnect six connectors [2], and take out the punch driver PCB [3].

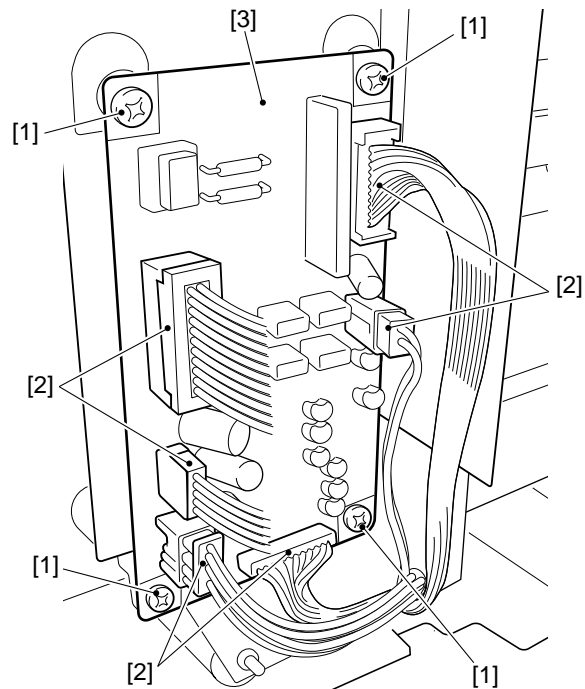

Figure 5-315

CHAPTER 6

MAINTENANCE AND INSPECTION

I. PERIODICALLY REPLACED PARTS	6-1
A. Finisher Unit	6-1
B. Saddle Stitcher Unit	6-1
C. Puncher Unit (option)	6-1

II. CONSUMABLES AND DURABLES	6-2
A. Finisher Unit	6-2
B. Saddle Stitcher Unit	6-2
C. Puncher Unit (option)	6-2
III. PERIODICAL SERVICING	6-2

I. PERIODICALLY REPLACED PARTS

A. Finisher Unit

The finisher unit does not have parts that must be replaced on a periodical basis.

B. Saddle Stitcher Unit

The saddle stitcher unit does not have parts that must be replaced on a periodical basis.

C. Puncher Unit (option)

The puncher unit does not have parts that must be replaced on a periodical basis.

II. CONSUMABLES AND DURABLES

Some of the parts of the machine may must be replaced once or more times because of wear or tear during the machine’s warranty period. Replace them as necessary.

A. Finisher Unit

No.	Name	Q'ty	Estimated Life	Remarks
1	Stapler	1	500,000 operations	5,000 operations/cartridge
2	Knurled belt	2	2,000,000 copies	
3	Paddle	2	1,000,000 copies	Paddle unit
		4		Paddle rubber only

B. Saddle Stitcher Unit

No.	Name	Q'ty	Estimated Life	Remarks
1	Stitcher	2	200,000 operations	2,000 operations/cartridge

C. Puncher Unit (option)

No.	Name	Q'ty	Estimated Life	Remarks
1	Punch unit	1	1,000,000 operations	

III. PERIODICAL SERVICING

Item	Interval	Work	Remarks
Knurled belt	Host machine minimum servicing interval	Cleaning	Use moist cloth
Paddle			Use dry cloth
Transmission sensor (Puncher Unit) (option)			

CHAPTER 7

TROUBLESHOOTING

I. ADJUSTMENTS	7-1	III. ARRANGEMENT OF ELECTRICAL PARTS	7-10
A. Electrical System (finisher unit)	7-1	A. Finisher Unit	7-10
B. Electrical System (saddle stitcher unit)	7-4	B. Saddle Stitcher Unit	7-18
C. Electrical System (puncher unit (option))	7-6	C. Puncher Unit (option)	7-26
II. TEST MODE	7-7	D. Light-Emitting Diodes (LED) and Check Pins by PCB	7-30
A. Finisher Unit	7-7	IV. TROUBLESHOOTING	7-32
B. Saddle Stitcher Unit	7-8	A. Finisher Unit	7-32
		B. Saddle Stitcher Unit	7-42
		C. Puncher Unit (option)	7-50

I. ADJUSTMENTS

Note

Before performing each adjustment, make sure that all covers (incl. those of the finisher and host machine) are closed. Otherwise, the power is not supplied to the finisher and the adjustment may not be performed properly.

A. Electrical System (finisher unit)

1. Adjusting the Height Sensor (PS1)

Perform the following adjustments whenever you have replaced the finisher controller PCB or the height sensor to set the threshold value for the compensating disparity of each sensor and to detect a stack-full situation on the tray.

- 1) Set DIP_SW (SW3) on the finisher controller PCB as indicated.

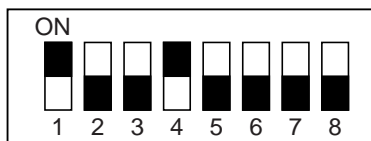

Figure 7-101

- 2) Stack one sheet of white paper on the tray.
- 3) Turn SW1 on the finisher controller PCB ON. (Adjustment starts.)
 - The trays move to the respective ranging adjustment position.
 - Entry of ranging compensation value
 - ↓
 - Tray 1 home position
 - ↓
 - Tray 2 home position
 - At the end of adjustment, the trays return to their home positions.
 - During adjustment, LED1 flashes. At the end of adjustment, LED1 comes ON.
 - If adjustment fails, the mechanism stops. At the same time, LED1 goes OFF.

- 4) Exiting the adjustment mode
Shift all bits on the DIP_SW OFF and turn the host machine OFF then, ON again.
Turn the host machine OFF, then ON again for readjustment, too.

2. Adjusting the Alignment Position

Adjust as follows if you have replaced the finisher controller PCB or if an alignment fault occurs.

- 1) Set DIP_SW (SW3) on the finisher controller PCB as indicated.

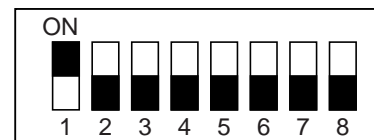

Figure 7-102

- 2) If you are using A4 paper for the adjustment, press SW1 on the finisher controller PCB. If you are using LT paper for the adjustment, press SW2 on the finisher controller PCB.
Pressing SW1 (SW2) opens the swing guide and causes the alignment guide to move to A4 (LT) positions.
- 3) Place two sheets of A4 (LT) paper between the alignment guide and the guide plate, butting them against the stoppers.
- 4) Press SW1 or SW2 on the finisher controller PCB and butt the alignment guide against the sheets.
 - Each press of SW1 shifts the alignment guide towards the front in 0.35 mm increments.
 - Each press of SW2 shifts the alignment guide towards the rear in 0.35 mm increments.
- 5) Press SW1 and SW2 simultaneously to store the adjustment value.
- 6) Exiting the adjustment mode
Shift all bits on the DIP_SW OFF and turn the host machine OFF, then ON again.
Turn the host machine OFF, then ON again for readjustment, too.

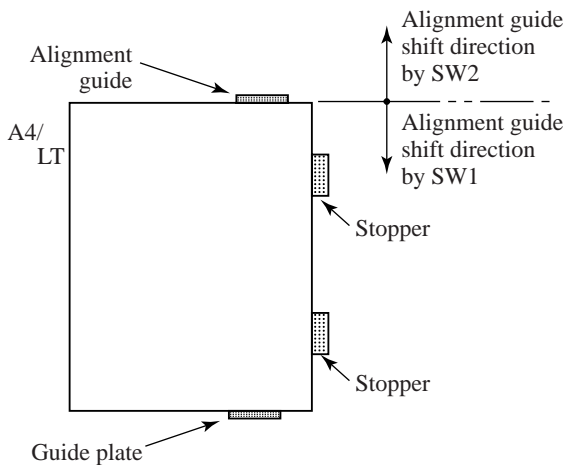

Figure 7-103

3. Adjusting the Staple Position

Adjust as follows if you have replaced the finisher controller PCB. Performing the following procedure affects all paper sizes and all stapling positions.

- 1) Set DIP_SW (SW3) on the finisher controller PCB as follows.

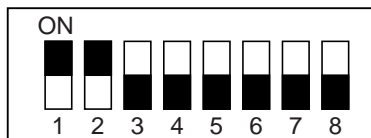

Figure 7-104

- 2) If you are using A4 paper for the adjustment, press SW1 on the finisher controller PCB. If you are using LT paper for the adjustment, press SW2 on the finisher controller PCB.

Pressing SW1 (SW2) opens the swing guide and causes the knurled belt to rotate.

- 3) Within five seconds after pressing the switch, place two sheets of A4 (LT) paper between the alignment guide and the guide plate, butting them against the stoppers.

- When the finisher detects the paper, it lowers the swing guide and performs stapling (rear, 1-position). Note, however, that manually stapled paper should be taken out as delivery is not performed.
- 4) If the stapling position is correct, set all bits of the DIP_SW to OFF to end the adjustments. If you need to change the stapling position, adjust by performing the following procedure.
 - 5) To match the position of the staple on the paper, press SW1 or SW2 on the finisher controller PCB for the necessary number of times.
 - Each press of SW1 shifts the stapling position towards the front in 0.3 mm increments.
 - Each press of SW2 shifts the stapling position towards the rear in 0.3 mm increments.
 - 6) Press SW1 and SW2 simultaneously.
 - This opens the swing guide, and causes the knurled belt to rotate. Placement of two sheets of A4 (LT) paper causes the finisher to start stapling.
 - 7) Check the stapling position. If good, set all bits of the DIP_SW to OFF. If readjustments are necessary, repeat the adjustment from step 5).

Note

The settings held by the finisher controller PCB are changed as soon as SW1 or SW2 is pressed. As such, to recover the previous settings after pressing these switches, you must press the other of the two switches as many times as you pressed previously.

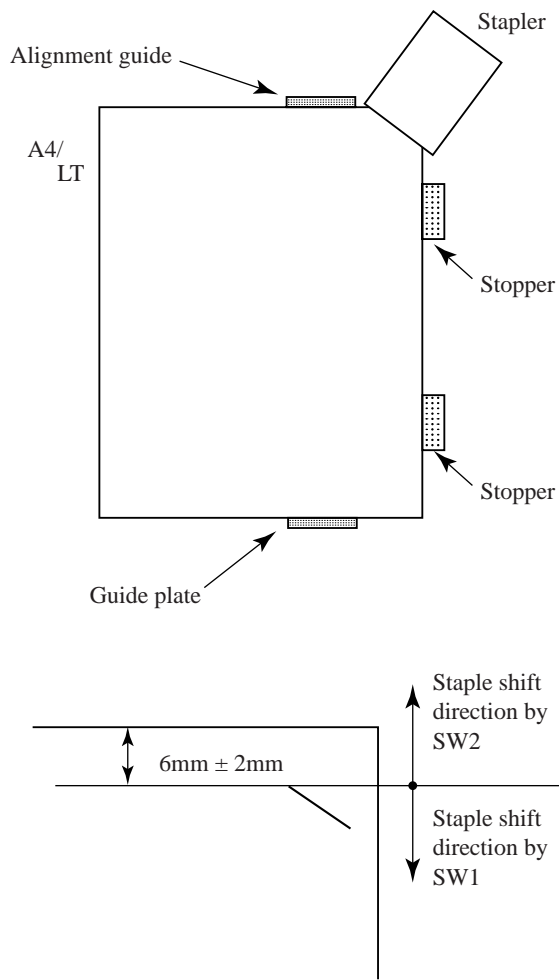

Figure 7-105

4. Clear the limit of stacking capacity

Set this when the limit of the staple stacking capacity needs to be cleared.

- 1) Set DIP_SW (SW3) on the finisher controller PCB as indicated.

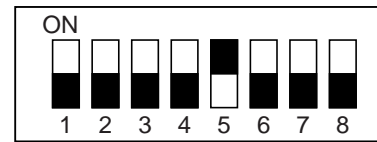

Figure 7-106

Note

When the limit of the staple stacking capacity is cleared, the following disadvantages may occur. Be sure to explain them to the user.

- If there is a large-volume stacking sheet, it may fall the tray.
- Paper positioning may become bad.

B. Electrical System (saddle stitcher unit)

1. Adjusting the Folding Position

The folding position is adjusted by changing the settings of bits 6 through 8 of DIP_SW1 on the saddle stitcher controller PCB to match the stitching position (that is, by adjusting the distance over which the paper positioning plate is moved to the folding position from the stitching position). If you have replaced the saddle stitcher controller PCB, be sure to set the new DIP_SW1 so that the settings are the same as those on the old DIP_SW1. If, for any reason, you must change the folding position, perform the following procedure.

- 1) Set bits 1 through 4 of DIP_SW1 on the saddle stitcher controller PCB as indicated.

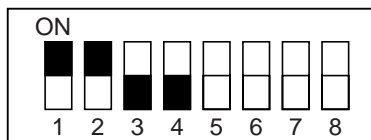

Do not change bits 5 through 8 here.

Figure 7-107

- 2) Remove the rear cover of the saddle stitcher unit, and tape the actuators of the inlet cover sensor (P19S) and the inlet door switch (MS1S) of the saddle stitcher unit in place.
- 3) Press SW2 on the saddle stitcher controller PCB so that the feed motor (M1S) starts to rotate.

Pressing SW2 for one second or less allows the A3 paper adjustment mode to enter. Pressing SW2 for three seconds or more allows the LD paper adjustment mode to enter.

- 4) Before inserting the paper, mark the top of the it. Use two sheets of A3 or LD paper.

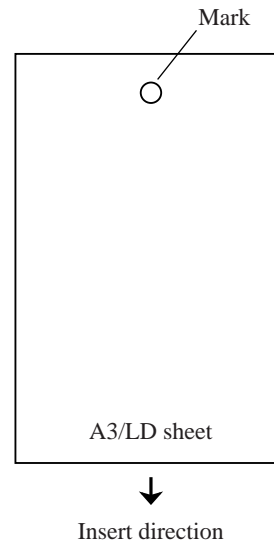

Figure 7-108

- 5) Open the inlet cover and insert two sheets of paper. Push them in by hand until the leading edge of the sheets butt against the paper positioning plate.
- 6) Close the inlet door.
- 7) Press SW2 on the saddle stitcher controller PCB.
 - The saddle stitcher unit stitches the sheets, then folds and delivers the stack automatically.
- 8) Measure the distance (L) between the stitching position and the folding position. Then, perform “positive width adjustment” or “negative width adjustment” to suit the relationship between the stitching position and folding position.
 - If the stitching position is below the folding position, perform “positive width adjustment.”
 - If the stitching position is above the folding position, perform “negative width adjustment.”

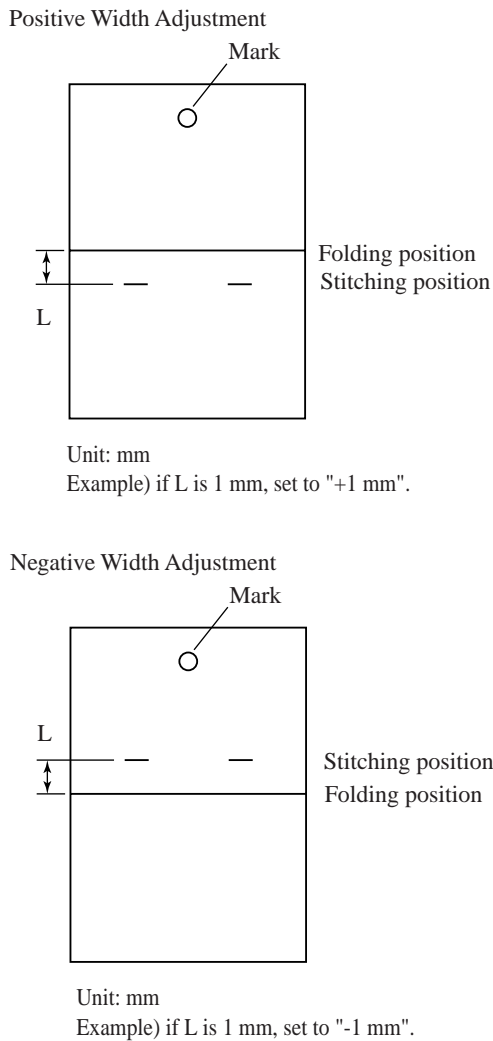

Figure 7-109

- 9) Change the settings of bits 6 through 8 of DIP_SW1 to match distance L referring to the table below.
- If the width adjustment is “0”
The stitching position and the folding position match, requiring no change.
 - In the case of “positive width adjustment”
Set DIP_SW1 so that the difference obtained by subtracting the interval from the appropriate setting is provided.
Example) If DIP_SW1 is currently set to +2 and the interval is +1 mm, set DIP_SW1 to “0”.
 - In the case of “negative width adjustment”
Set DIP_SW1 so that the sum obtained by adding the interval from the appropriate setting is provided.
Example) If DIP_SW1 is currently set to -1 and the interval is -1.0 mm, set DIP_SW1 to “+1”.

DIPSW1 bit settings			Settings (in units of 0.25 mm)
bit 6	bit 7	bit 8	
OFF	ON	ON	+3 (+1.5mm)
OFF	ON	OFF	+2 (+1.0mm)
OFF	OFF	ON	+1 (+0.5mm)
OFF	OFF	OFF	0
ON	OFF	ON	-1 (-0.5mm)
ON	ON	OFF	-2 (-1.0mm)
ON	ON	ON	-3 (-1.5mm)

Do not change the following bit settings:

bit 6	bit 7	bit 8
ON	OFF	OFF

Table 7-101

- 10) Set bits 1 through 4 of DIP_SW1 to OFF.

2. Stitching Position (adjusting center stitching)

Use the host machine user mode to perform the following.

For details of adjustment methods, refer to the Operator’s Manual for the host machine.

C. Electrical System (puncher unit (option))

1. Sensor output adjustment

Perform this adjustment when the punch driver PCB, transmission sensor (photosensor PCB/LED PCB) or reflection sensor (scrap-full detection PCB unit) has been replaced.

- 1) Remove the rear cover of the finisher unit.
- 2) Set bits 1 through 6 of DIPSW3 on the finisher controller PCB as indicated.

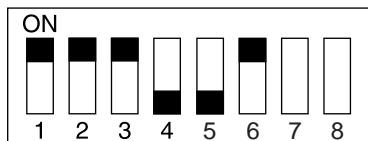

Figure 7-110

- 3) Press SW1 on the finisher controller PCB. Pressing this switch automatically adjusts sensor output.
- 4) Set all bits on DIPSW3 to OFF.

2. Registering the number of punch holes

This operation registers which puncher unit is attached to the IC on the punch driver PCB so that the puncher unit can be identified by the finisher. For this reason, this operation must be performed when the punch driver PCB has been replaced.

- 1) Remove the rear cover of the finisher unit.
- 2) Set bits 1 through 6 of DIPSW3 on the finisher controller PCB as indicated.

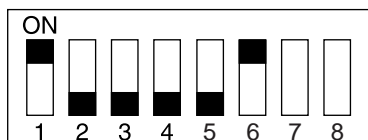

Figure 7-111

- 3) Set bits 7 and 8 on DIPSW3 on the finisher controller PCB to match the number of punch holes of the attached puncher unit according to Table 7-102.

Number of Punch Holes	DIPSW3 bit settings	
	bit 7	bit 8
2-hole (MJ-6002E)	OFF	OFF
2-/3-hole (MJ-6002N)	OFF	OFF
4-hole (MJ-6002F)	ON	OFF
4-hole (MJ-6002S)	ON	ON

Table 7-102

- 4) Press SW1 on the finisher controller PCB. Press SW2 when setting a 2-/3-hole model (MJ-6002N). Pressing this switch registers the number of punch holes to the punch driver PCB.
- 5) Set all bits on DIPSW3 to OFF.

3. Checking the sensitivity level of the transmission sensor

How dirty the transmission sensor (photosensor PCB/LED PCB) is, can be checked by the number of times that LED1 on the finisher controller PCB lights. For this reason, how dirty the transmission sensor is serves as a guide for when to perform cleaning during periodic maintenance.

- 1) Remove the rear cover of the finisher unit.
- 2) Set bits 1 through 6 of DIPSW3 on the finisher controller PCB as indicated.

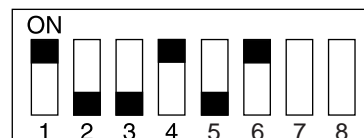

Figure 7-112

- 3) Press SW1 on the finisher controller PCB. Pressing this switch lights LED1 on the finisher controller PCB as indicated in Table 7-103 so that you can check the sensitivity level of the transmission sensor.

Sensitivity Level	Number of LED Lightings
Sensor not dirty	Lit 1X
Sensor slightly dirty	Lit 2X
Sensor dirty	Lit 3X

Table 7-103

- 4) Set all bits of DIPSW3 to OFF.

II. TEST MODE

A. Finisher Unit

1. Feeding speed check

Confirm that the feeding speed is 650 mm/sec or more with the delivery motor in a fully ON state.

Confirm that teaching of the delivery motor can be performed normally.

- 1) Set DIP_SW on the finisher controller PCB as indicated.

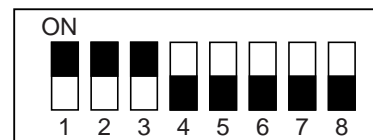

Figure 7-201

- 2) Pressing PUSH_SW1 causes the delivery motor to rotate. The number of pulses output from the delivery motor encoder is calculated, and LED1 either lights or goes out according to the following conditions.

Feeding speed

At 650 mm/sec or more, LED1 lights. (normal)

At less than 650 mm/sec, LED1 is out. (abnormal)

2. First feed motor operation check

First feed motor operation mode

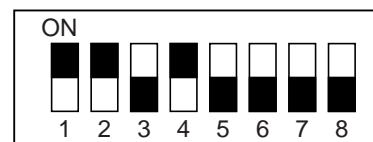

Figure 7-202

- 1) Pressing PUSH_SW1 starts the operation.
- 2) Pressing PUSH_SW2 stops the operation.

3. Tray shift up check

Raise the bin. (DIP_SW all OFF)

- 1) Pressing PUSH_SW1 causes the bin to rise.
- 2) Bin shift is canceled when PUSH_SW1 is pressed at the No.2 bin position.

4. Tray shift down check

Lower the bin. (DIP_SW all OFF)

- 1) Pressing PUSH_SW2 causes the bin to lower.
- 2) Bin shift is canceled when PUSH_SW2 is pressed at the No.1 bin position.

5. The silent sound mode

In order to lessen the motor driving noise when the tray is moving, the rotation speed for moving the tray up and down has been reduced.

- 1) Turn off the power supply.
- 2) Remove the rear cover of the finisher.
- 3) The DIP-SW setting of the finisher controller board is made as follows.

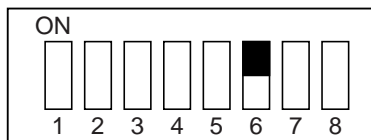

Figure 7-203

- 4) Install the rear cover of the finisher.
- 5) Turn ON the power supply.

B. Saddle Stitcher Unit

1. Feed motor operation check

Feed motor operation mode

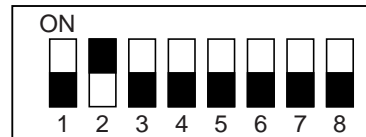

Figure 7-204

- 1) Pressing PUSH_SW2 starts the operation. Each press of PUSH_SW2 changes the control speed as follows:
The (1) 170 mm/sec → (2) 420 mm/sec → (3) Operation stopped cycle is repeated.

2. Paper folding motor operation check

Paper folding motor operation mode

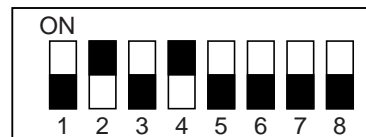

Figure 7-205

- 1) Pressing PUSH_SW2 starts the operation. Each press of PUSH_SW2 changes control as follows:
The (1) Forward rotation → (2) Reverse rotation → (3) Operation stopped cycle is repeated.

3. Paper pushing plate motor operation check

Paper pushing plate motor operation mode

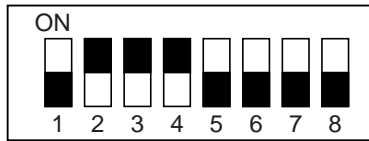

Figure 7-206

- 1) Pressing PUSH_SW2 twice starts the operation. Each press of PUSH_SW2 changes control as follows:
The (1) Forward rotation → (2) Reverse rotation cycle is repeated.

4. Alignment motor operation check

Alignment motor operation mode

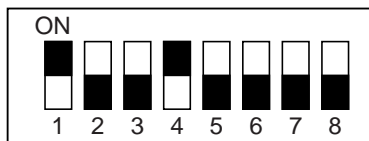

Figure7-207

- 1) Pressing PUSH_SW2 twice starts the operation. Each press of PUSH_SW2 changes control as follows:
The (1) 10 mm from side edge of paper → (2) Side edge of paper → (3) Home position cycle is repeated.

5. Paper positioning plate motor operation check

Paper positioning plate motor operation mode

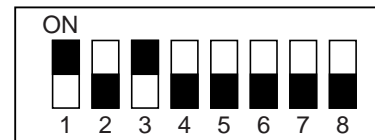

Figure 7-208

- 1) Pressing PUSH_SW2 twice starts the operation. Each press of PUSH_SW2 changes control as follows:
The (1) Folding position → (2) Stapling position → (3) Home position cycle is repeated.

6. Guide motor operation check

Guide motor operation mode

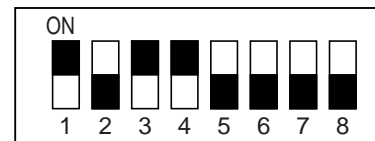

Figure 7-209

- 1) Pressing PUSH_SW2 twice starts the operation. Each press of PUSH_SW2 changes control as follows:
The (1) Stapling position → (2) Home position cycle is repeated.

III. ARRANGEMENT OF ELECTRICAL PARTS

A. Finisher Unit

1. Sensors

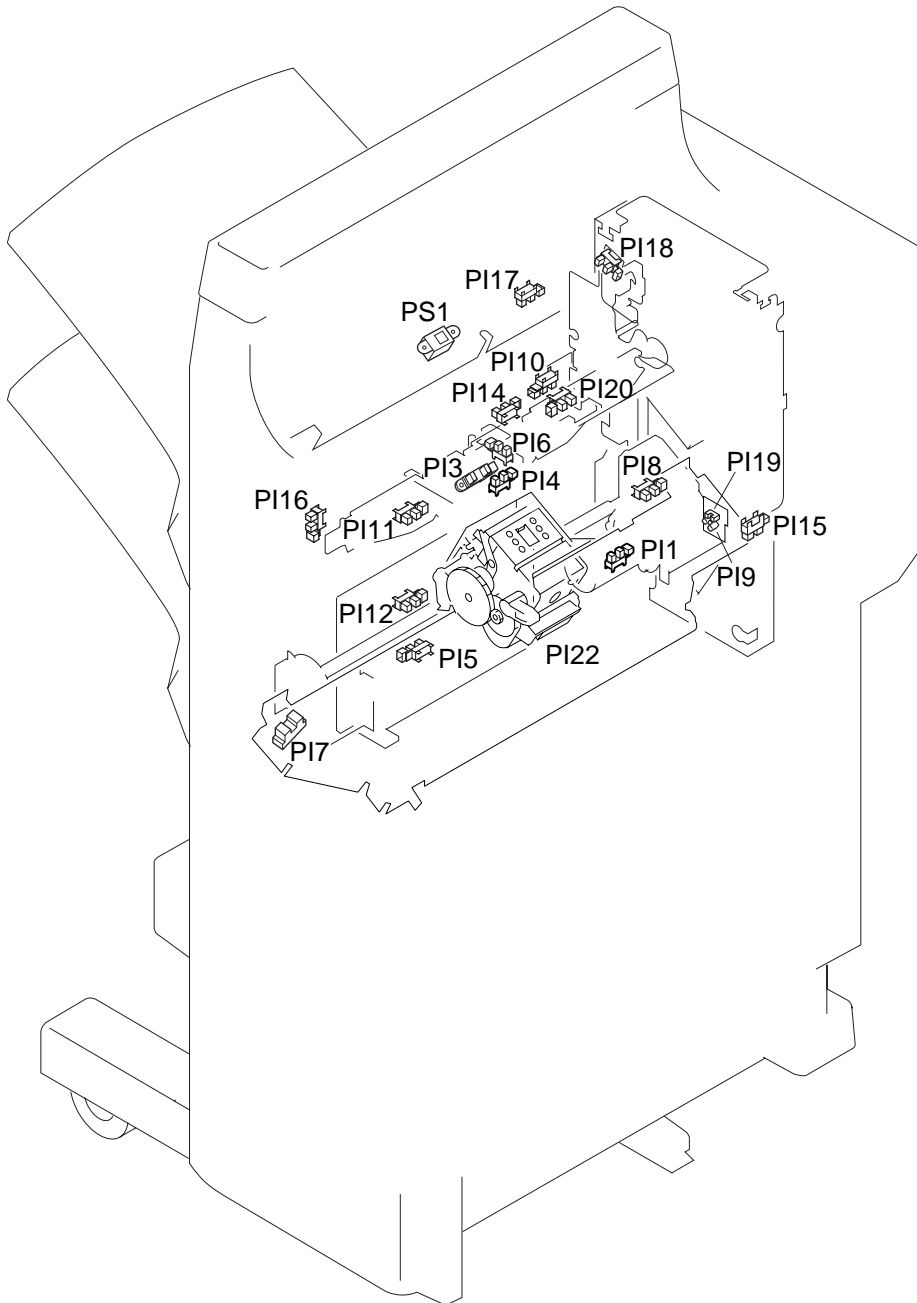

Figure 7-301

Name	Notation	Function
Photointerruptor	PI1	Detects paper in the inlet area
	PI3	Detects paper in the delivery area
	PI4	Detects paper on the stapling tray
	PI5	Detects the state (open) of the shutter
	PI6	Detects alignment guide at home position
	PI7	Detects the stapler at home position
	PI8	Detects the tray at home position
	PI10	Detects delivery motor clock pulses
	PI11	Detects paper on tray 1
	PI12	Detects paper on tray 2
	PI14	Detects paper in the buffer path
	PI15	Detects the finisher joint
	PI16	Detects the state (open) of the door
	PI17	Detects paper at the inlet to the buffer path
	PI18	Detects the state (open) of the swing guide
	PI9	Detects tray lift motor clock pulses 1 (on sensor PCB)
	PI19	Detects tray lift motor clock pulses 2 (on sensor PCB)
PI20	Detects swing guide clock	
PI22	Detects staple drive home position (inside stapler)	
Height sensor	PS1	Detects the height of the stack on the tray

Table 7-301

2. Microswitches

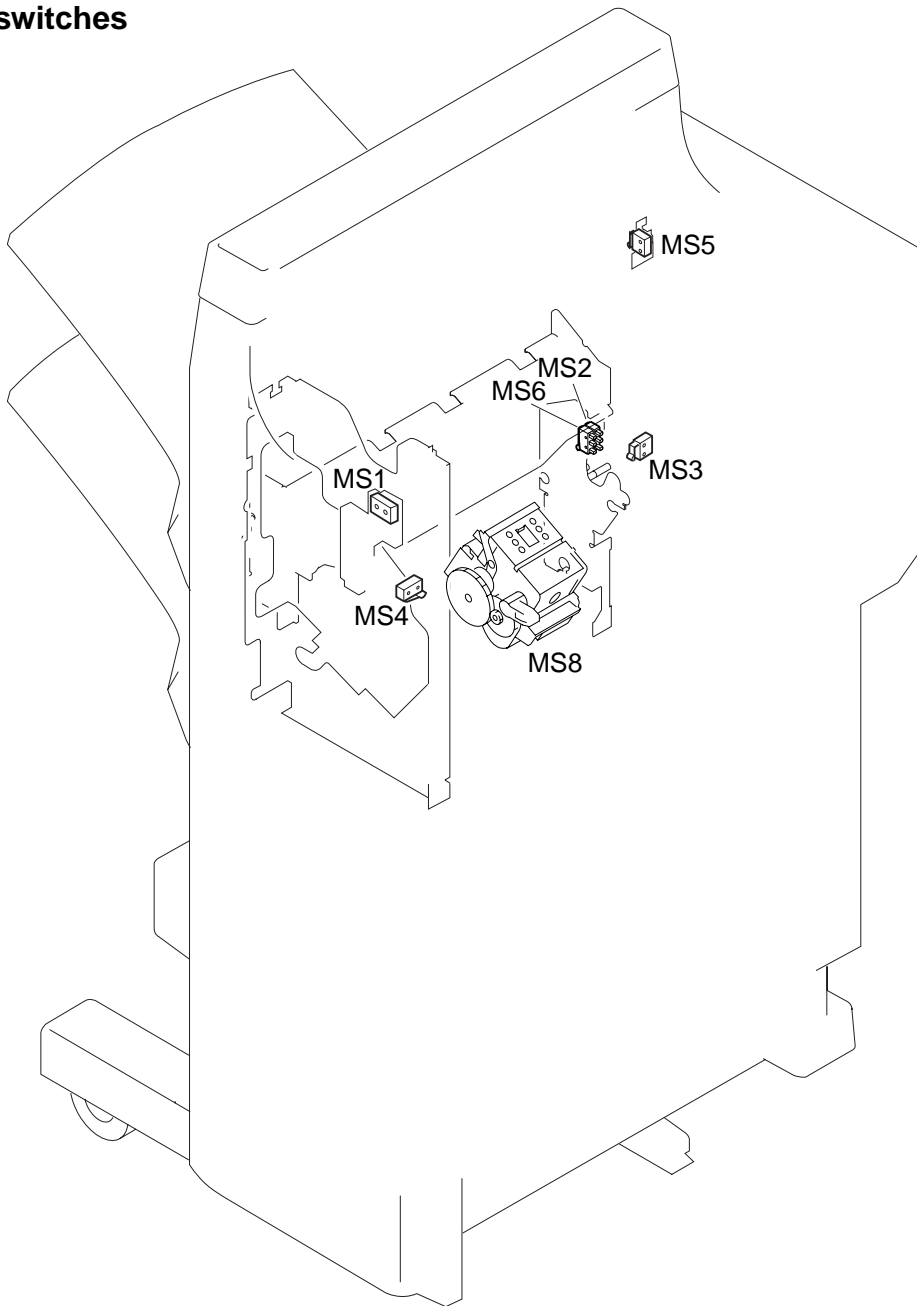

Figure 7-302

Name	Notation	Function
Microswitches	MS1	Detects the state (open) of the front door and the upper door
	MS2	Detects the state (closed) of the swing guide 1
	MS3	Detects the safety range
	MS4	Detects the state (closed) of the shutter
	MS5	Detects the tray at the upper limit
	MS6	Detects the state (closed) of the swing guide 2
	MS8	Detects the presence/absence of staples (inside stapler)

Table 7-302

3. Motors

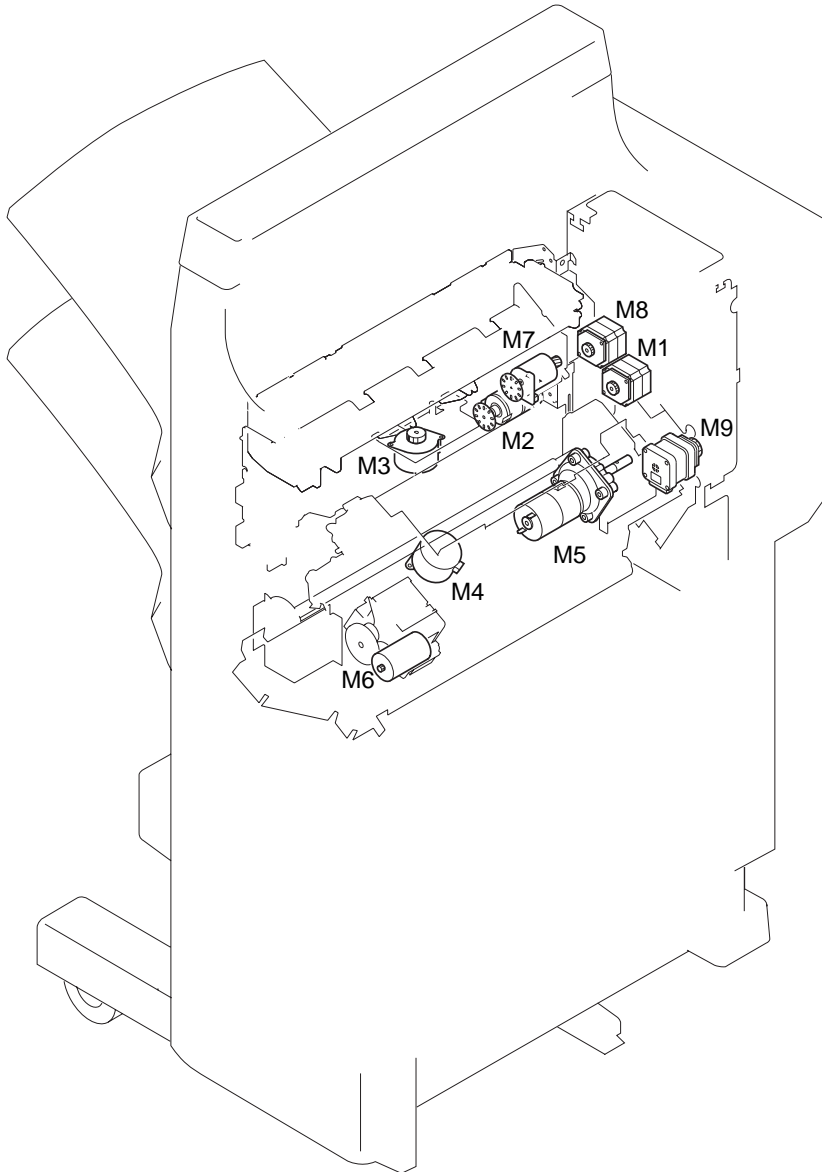

Figure 7-303

Name	Notation	Function
Motor	M1	First feed motor
	M2	Delivery motor
	M3	Alignment motor
	M4	Stapler shift motor
	M5	Tray lift motor
	M6	Staple motor
	M7	Swing motor
	M8	Second feed motor
	M9	Inlet feed motor

Table 7-303

4. Solenoids

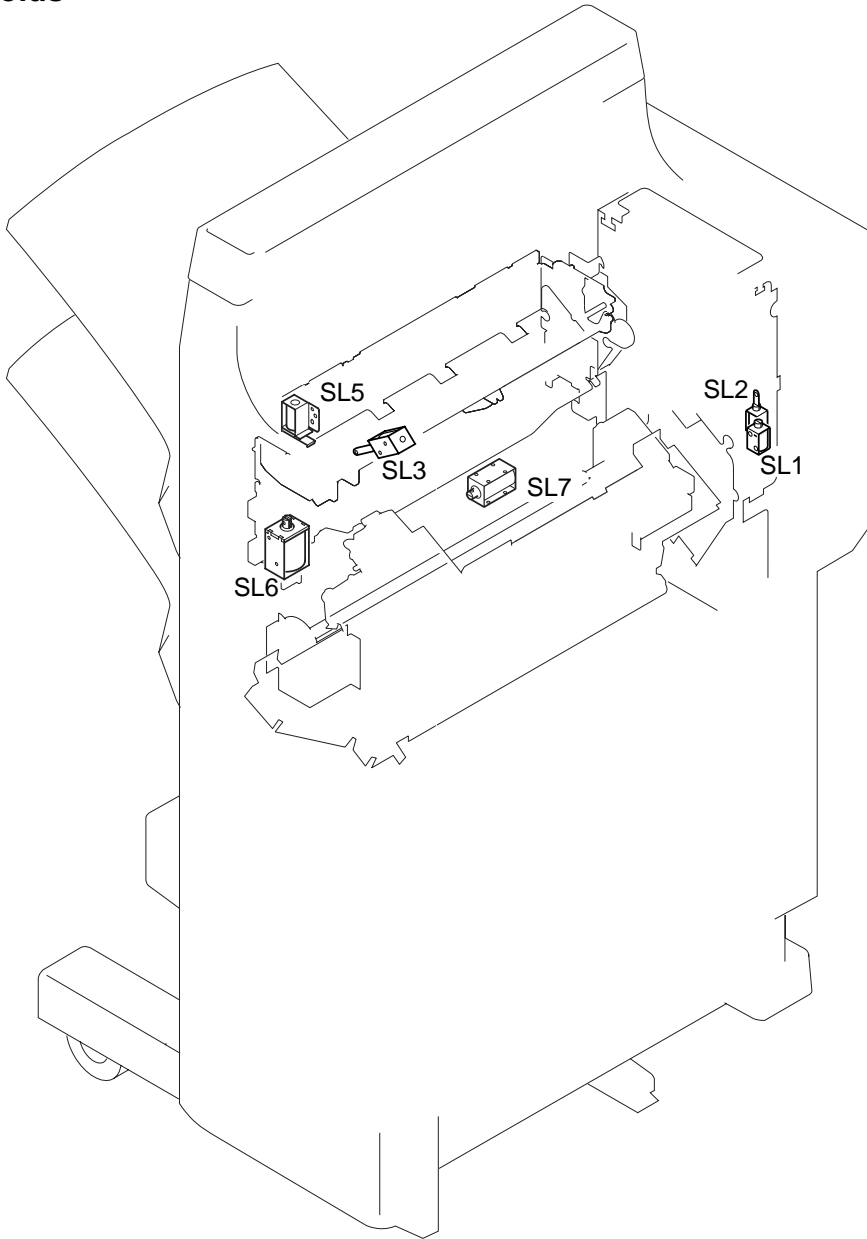

Figure 7-304

Name	Notation	Function
Solenoid	SL1	Flapper solenoid
	SL2	Buffer inlet solenoid
	SL3	Buffer outlet solenoid
	SL5	Paddle solenoid
	SL6	Escape solenoid
	SL7	Belt escape solenoid

5. PCBs

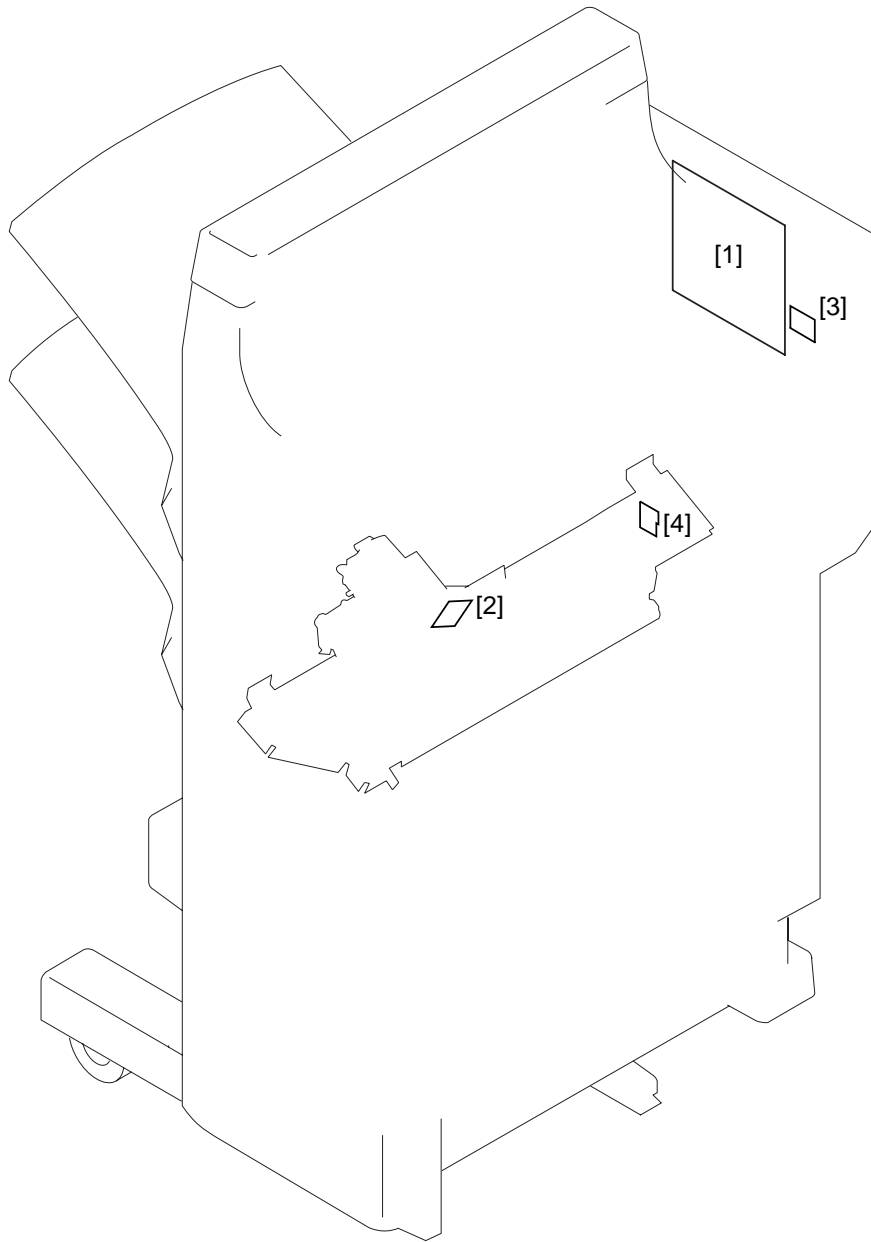

Figure 7-305

Reference	Name
[1]	Finisher controller PCB
[2]	Relay PCB 4
[3]	Relay PCB 3
[4]	Sensor PCB

Table 7-305

B. Saddle Stitcher Unit

1. Photointerruptors

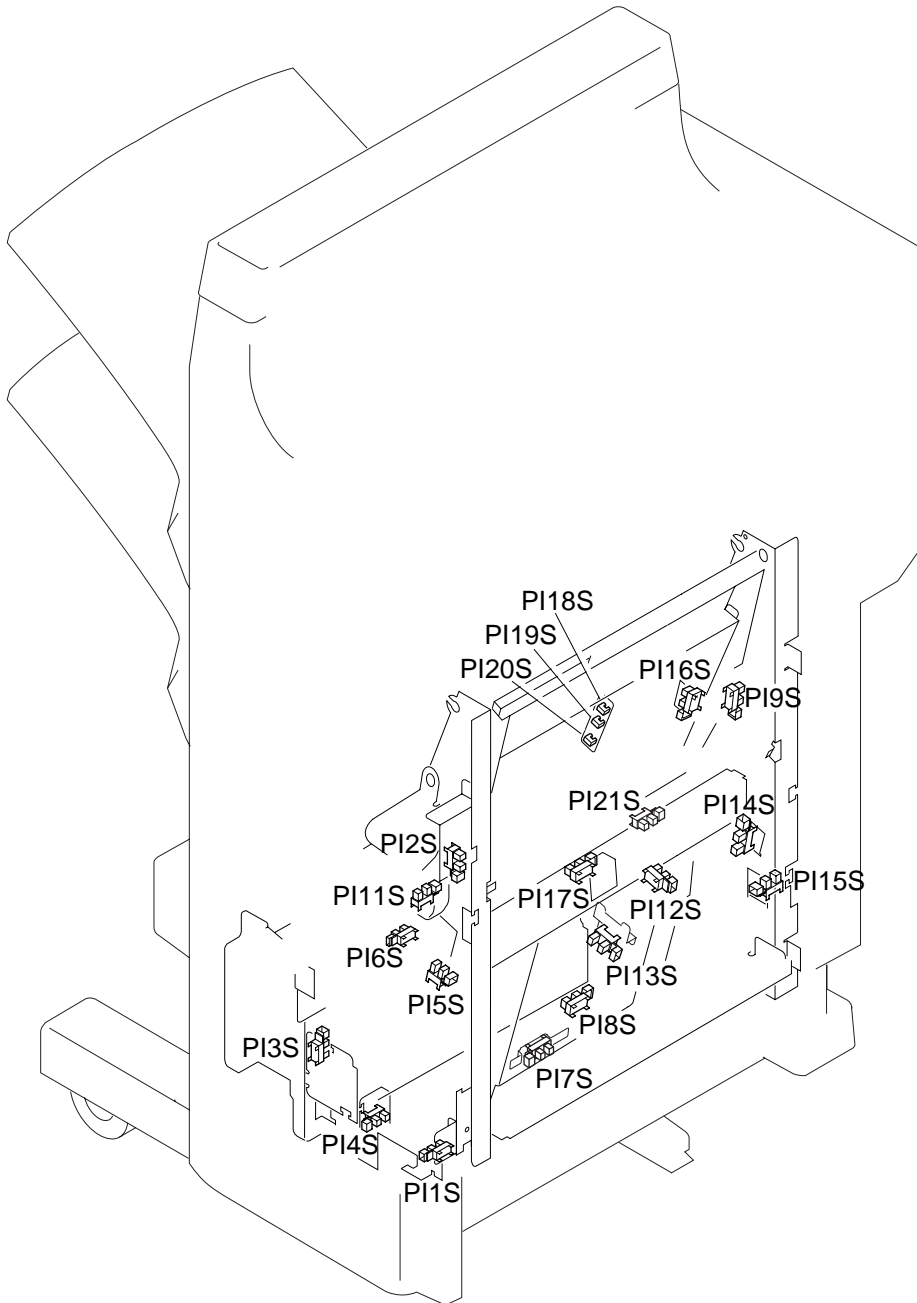

Figure 7-306

Name	Notation	Function
Photointerruptor	PI1S	Detects clock pulses from the paper pushing plate motor
	PI2S	Detects the state (open) of the front cover
	PI3S	Detects the state (open) of the delivery cover
	PI4S	Detects clock pulses from the paper folding motor
	PI5S	Detects the alignment plates at home position
	PI6S	Detects paper on the tray
	PI7S	Detects paper positioning plate at home position
	PI8S	Detects paper on the paper positioning plate
	PI9S	Detects the state (open) of the inlet cover
	PI11S	Detects paper in the delivery area
	PI12S	Detects the phase of the crescent roller
	PI13S	Detects the guide at home position
	PI14S	Detects the paper pushing plate at home position
	PI15S	Detects the paper pushing plate at top position
	PI16S	Detects the state (in) of the stitcher unit
	PI17S	Detects paper in the vertical path
	PI18S	Detects paper (No. 1; on paper sensor PCB)
	PI19S	Detects paper (No. 2; on paper sensor PCB)
	PI20S	Detects paper (No. 3; on paper sensor PCB)
	PI21S	Detects the paper folding at the home position

Table 7-306

2. Microswitches

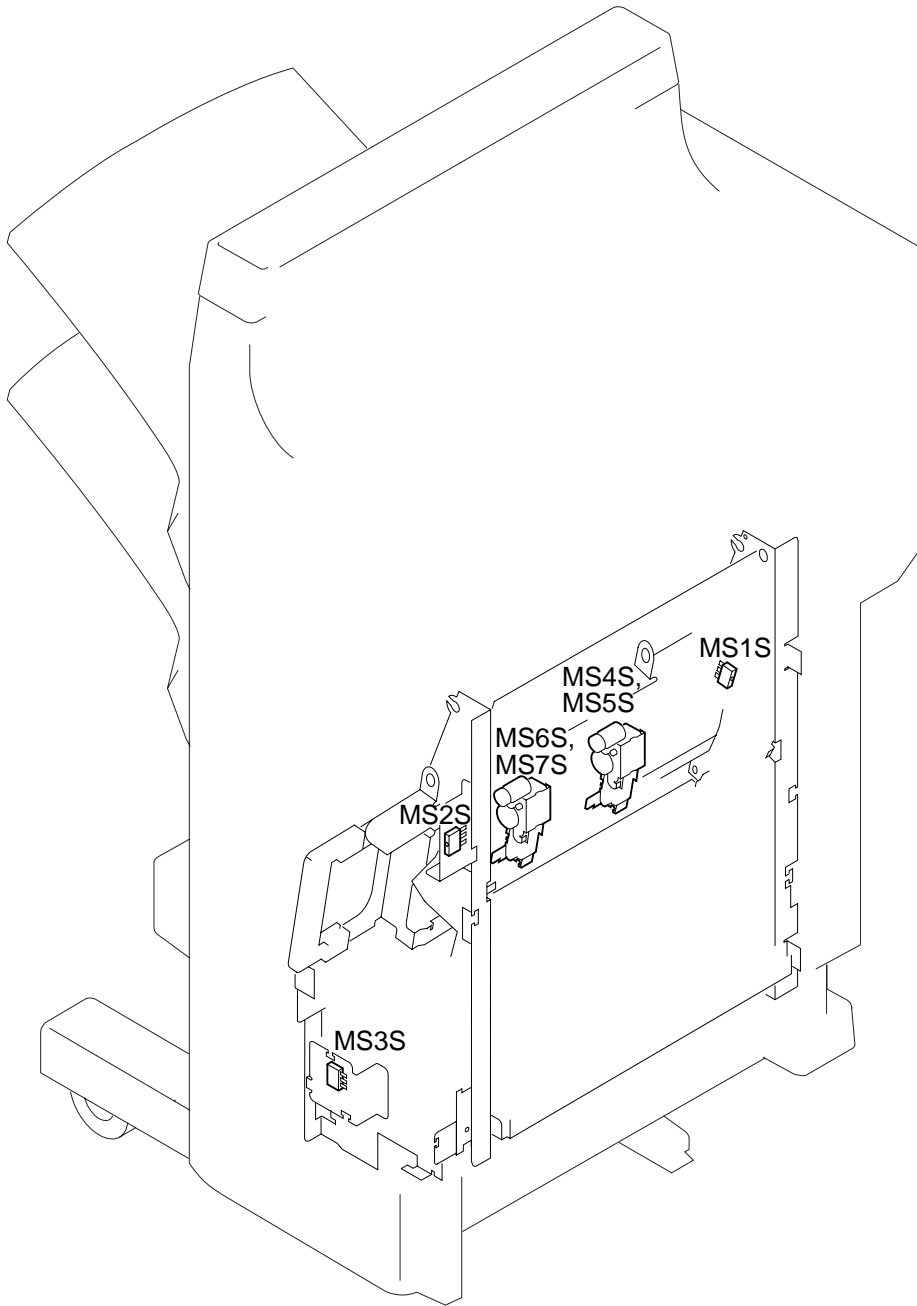

Figure 7-307

Name	Notation	Function
Microswitches	MS1S	Detects the state (open) of the inlet cover
	MS2S	Detects the state (open) of the front cover
	MS3S	Detects the state (open) of the delivery cover
	MS4S	Detects the presence of staples (rear)
	MS5S	Detects stitching home position (rear)
	MS6S	Detects the presence of staples (front)
	MS7S	Detects the stitching home position (front)

Table 7-307

3. Motors

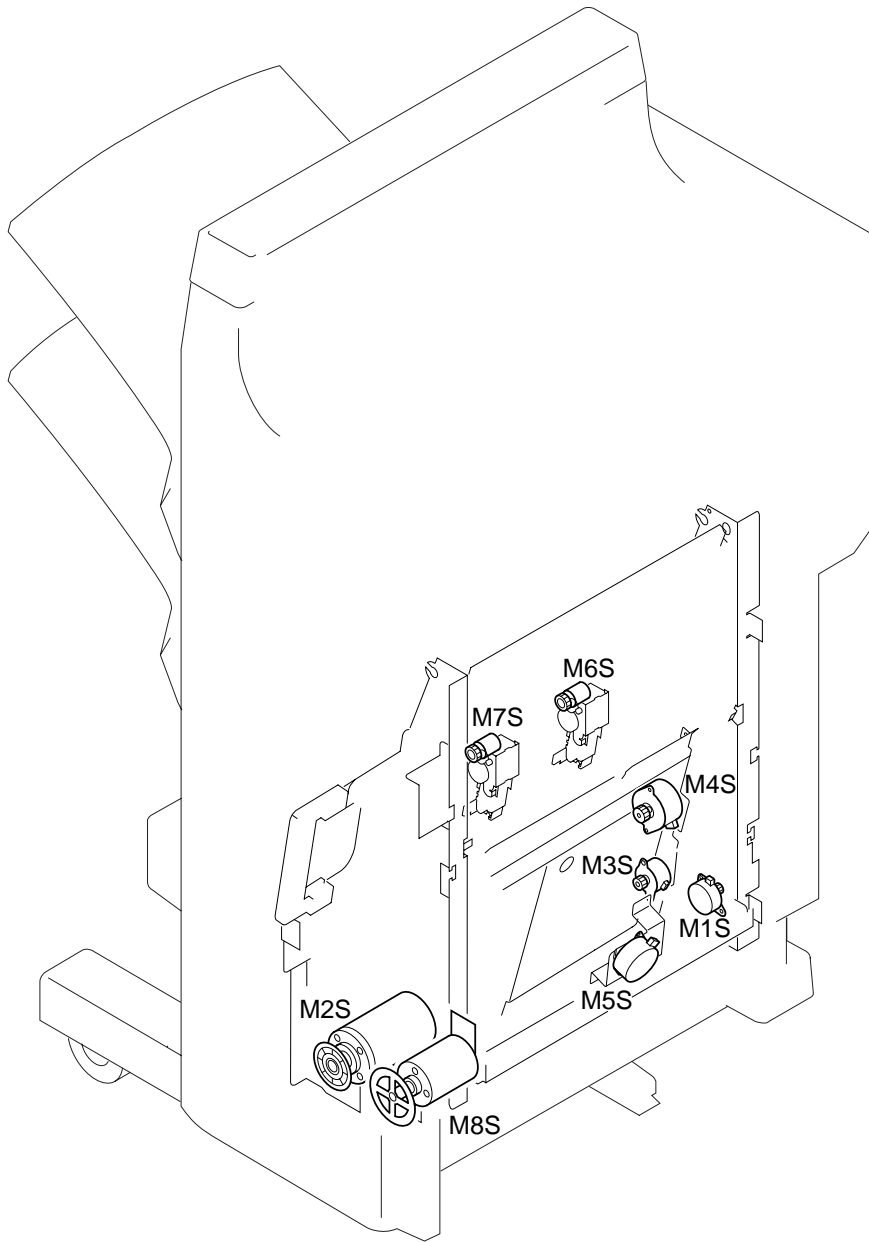

Figure 7-308

Name	Notation	Function
Motor	M1S	Feed motor
	M2S	Paper folding motor
	M3S	Guide motor
	M4S	Paper positioning plate motor
	M5S	Alignment motor
	M6S	Stitcher motor (rear)
	M7S	Stitcher motor (front)
	M8S	Paper pushing plate motor

Table 7-308

4. Solenoids

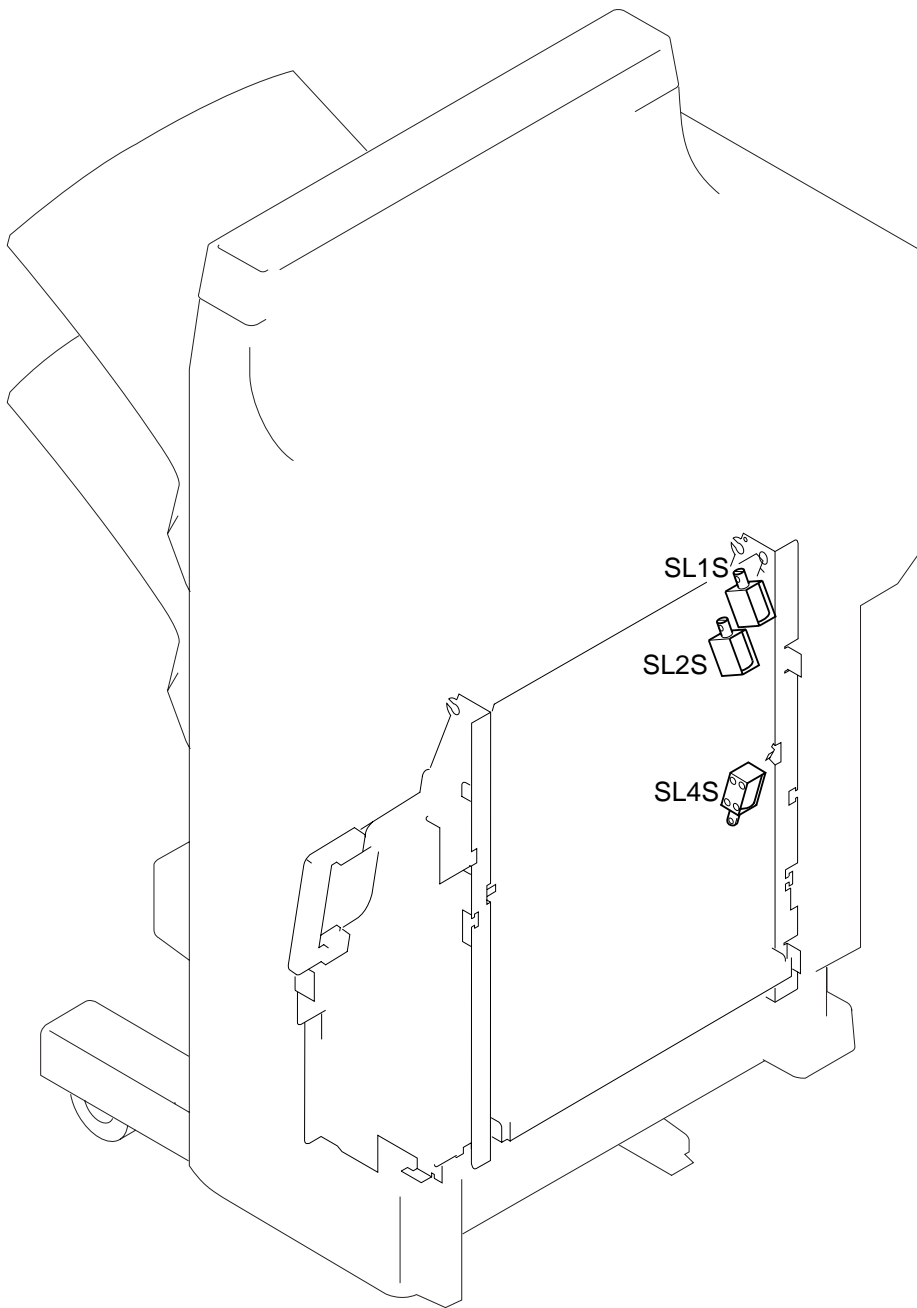

Figure 7-309

Name	Notation	Function
Solenoid	SL1S	No. 1 paper deflecting plate solenoid
	SL2S	No. 2 paper deflecting plate solenoid
	SL4S	Feed plate contact solenoid

Table 7-309

5. PCBs

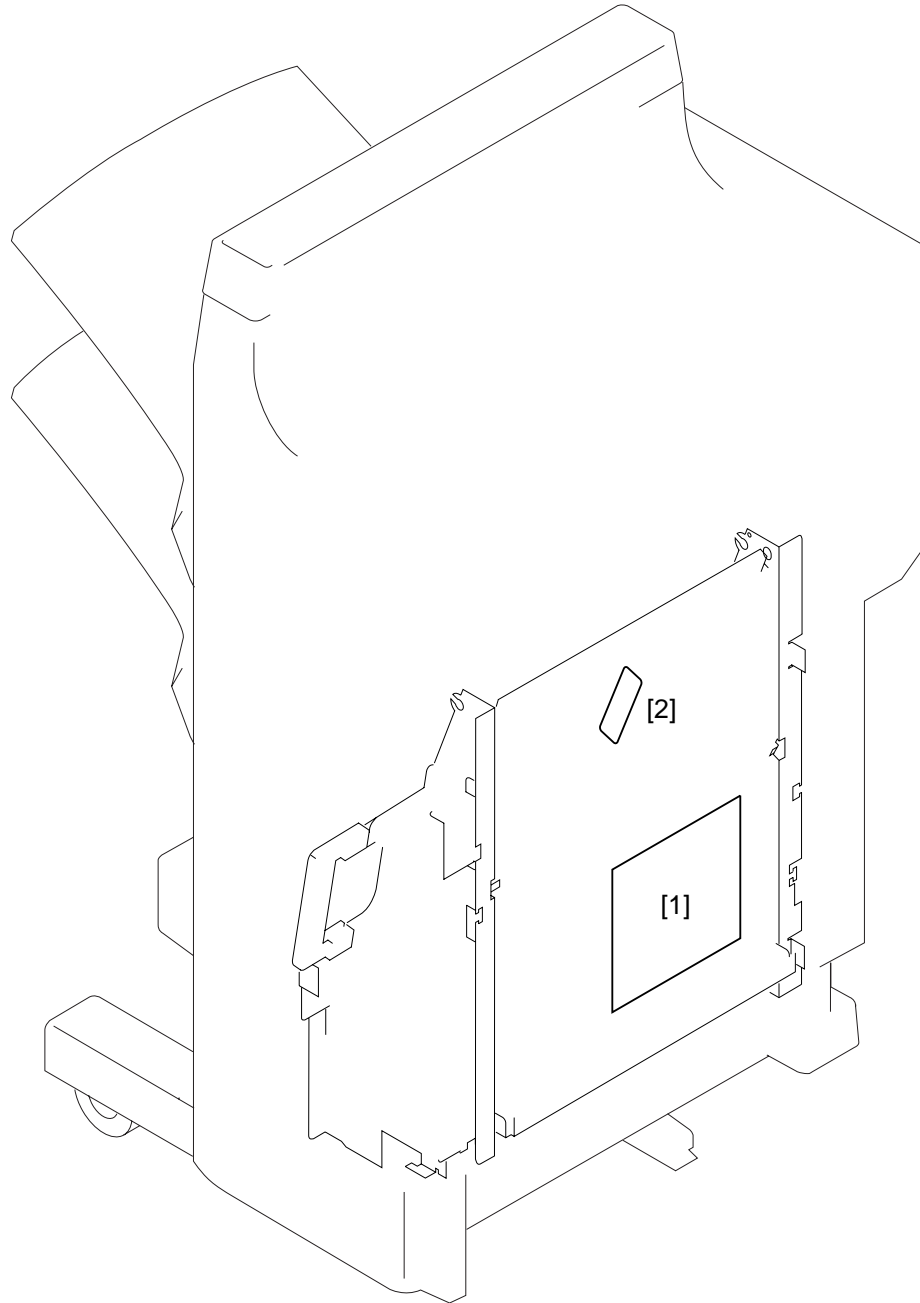

Figure 7-310

Reference	Name
[1]	Saddle stitcher controller PCB
[2]	Paper sensor PCB

Table 7-310

C. Puncher Unit (option)

1. Photointerruptors

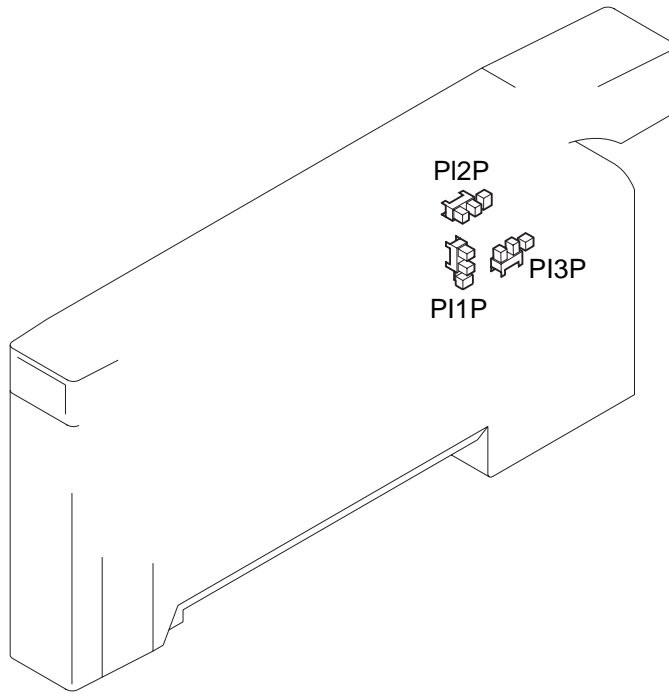

Figure 7-311

Name	Notation	Function
Photointerruptor	PI1P	Horizontal registration home position detection
	PI2P	Punch motor clock detection
	PI3P	Punch home position detection

Table 7-311

2. Microswitches

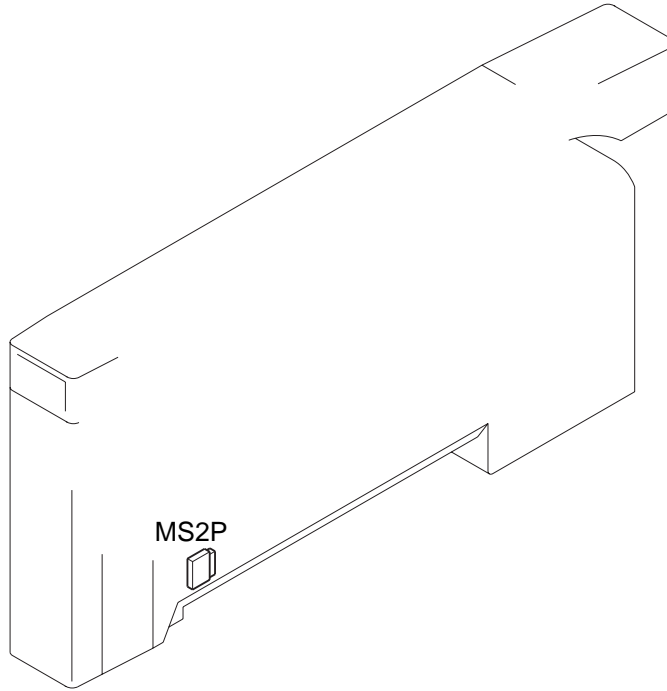

Figure 7-312

Name	Notation	Function
Microswitch	MS2P	Front door open detection

Table 7-312

3. Motors

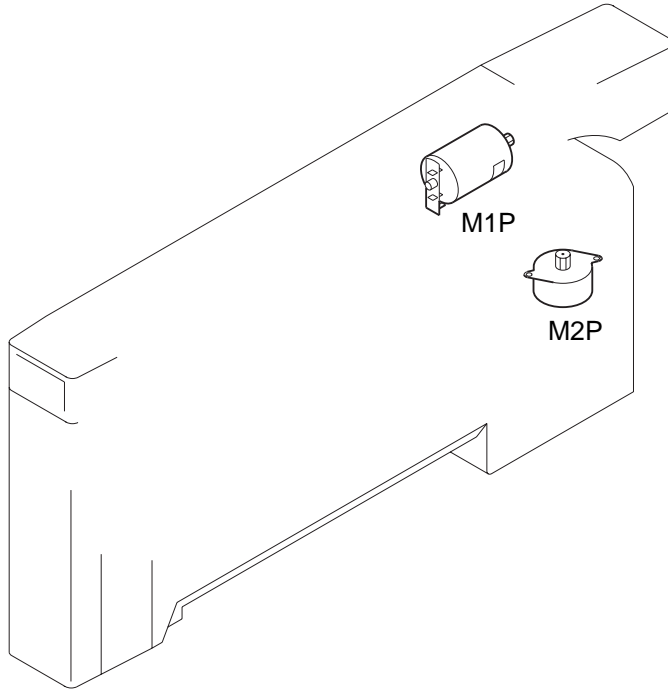

Figure 7-313

Name	Notation	Function
Motor	M1P	Punch motor
	M2P	Horizontal registration motor

Table 7-313

4. PCBs

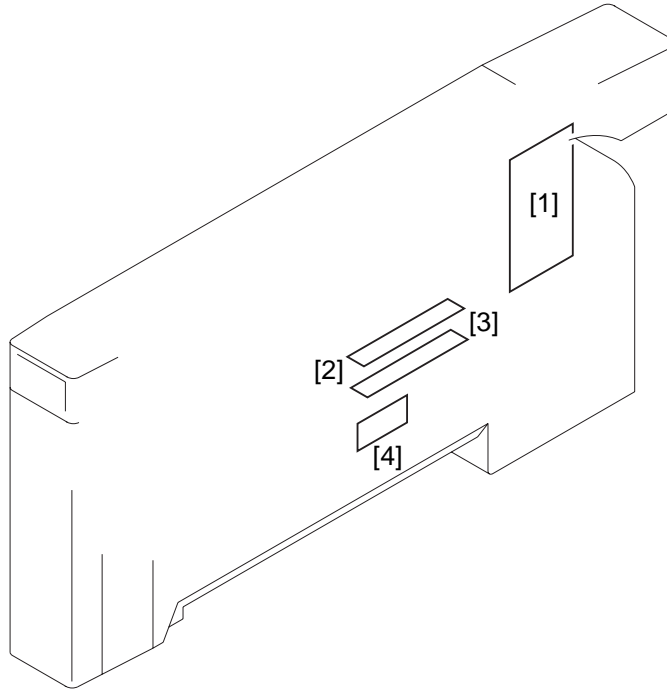

Figure 7-314

Reference	Name
[1]	Punch driver PCB
[2]	Photosensor PCB
[3]	LED PCB
[4]	Scrap-full detector PCB

Table 7-314

D. Light-Emitting Diodes (LED) and Check Pins by PCB

This section discusses the LEDs and check pins used in the machine that are needed in the field.

Note:

The VRs and check pins not discussed in this section are for factory use only. Making adjustments and checks using these will require special tools and instruments and adjustments must be to a high degree of accuracy. Do not touch them in the field.

1. Finisher Controller PCB

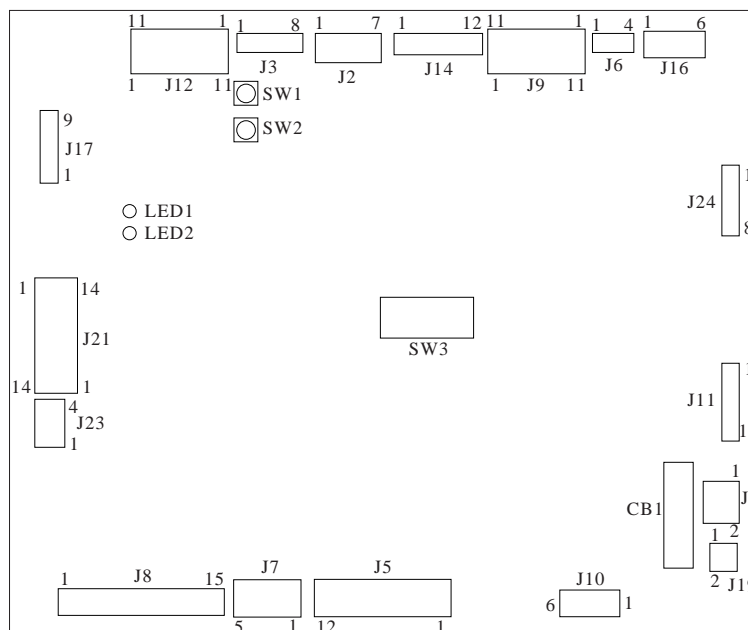

Figure 7-315

Switch	Function
SW1	Adjust the height sensor/alignment guide position/stapling position and move the trays up, etc.
SW2	Adjust the alignment guide position/staple position and move the trays down, etc.
SW3	Adjust the height sensor/alignment guide position and stapling position, etc.

Table 7-315

2. Saddle Stitcher Controller PCB

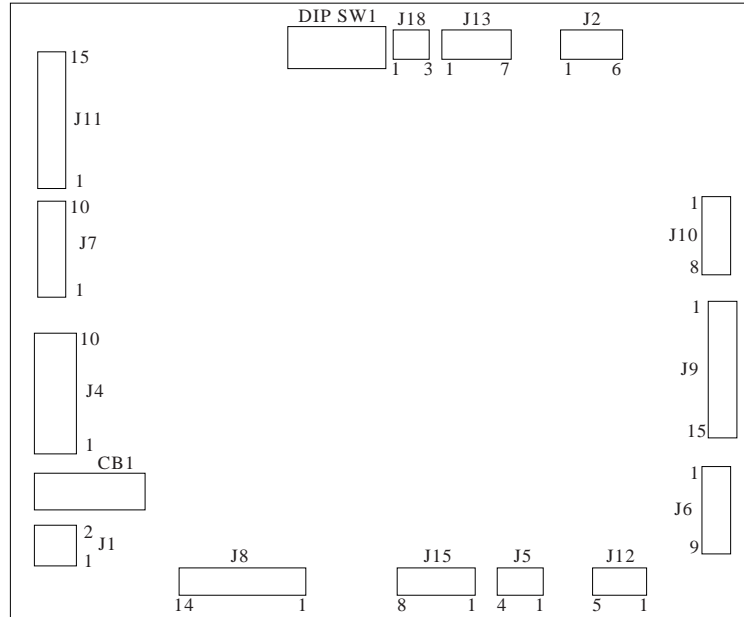

Figure 7-316

Switch	Function
DIPSW1 (bits 1-2)	Starts correction of discrepancy between stitching position and folding position.
DIPSW1 (bits 6-8)	Stores corrected settings for stapling position and folding position.
SW2	Starts correction of discrepancy between stitching position and folding position.

Table 7-316

IV. TROUBLESHOOTING

A. Finisher Unit

1. Fault in communication with host machine

Cause	Step	Checks	Yes/No	Action
Finisher controller PCB, Host machine DC controller PCB	1	Turn the host machine OFF, then ON. Is the problem corrected?	Yes	End.
Wiring	2	Is the wiring between the finisher controller PCB and the host machine controller PCB normal?	No	Correct it.
Finisher controller PCB, Host machine DC controller PCB	3	Replace the finisher controller PCB and the host machine DC controller PCB. Is the problem corrected?	Yes	End.

2. Fault in communication with saddle stitcher unit

Cause	Step	Checks	Yes/No	Action
Finisher controller PCB, Saddle stitcher controller PCB	1	Turn the host machine OFF, then ON. Is the problem corrected?	Yes	End.
Wiring	2	Is the wiring between the finisher controller PCB and the saddle stitcher controller PCB normal?	No	Correct it.
Power supply	3	Measure the voltage between J3-2 (+) and J3-1 (-) on the finisher controller PCB. Is it 24 VDC?	No	Replace the finisher controller PCB.
Saddle stitcher controller PCB			Yes	Replace the saddle stitcher controller PCB.

3. Faulty height sensor (communication)

Cause	Step	Checks	Yes/No	Action
Finisher controller PCB	1	Turn the host machine OFF, then ON. Is the problem corrected?	Yes	End.
Wiring	2	Is the wiring between the finisher controller PCB and the sensors normal?	No	Correct the wiring.
Power supply	3	Measure the voltage between J6-2 (+) and J6-4 (-) on the finisher controller PCB. Is it 5 VDC?	No	Replace the finisher controller PCB.
Height sensor (PS1)			Yes	Adjust the height sensor once again. If an error occurs again, replace the height sensor.

4. Faulty height sensor (disconnection)

Cause	Step	Checks	Yes/No	Action
Connector	1	Is J6 on the finisher controller PCB, J114 on the height sensor, or the relay connector J212 disconnected?	Yes	Connect the connector.
Power supply	2	Measure the voltage between J6-2 (+) and J6-4 (-) on the finisher controller PCB. Is it 5 VDC?	No	Replace the finisher controller PCB.
Height sensor (PS1)	3	Is the wiring between the finisher controller PCB and sensors normal?	Yes	Replace the height sensor.
Wiring			No	Correct the wiring.

5. Faulty height sensor (adjustment)

Cause	Step	Checks	Yes/No	Action
Adjustment	1	Try making adjustments using the DIP switch once again. Is the problem corrected?	Yes	End.
Wiring	2	Is the wiring between the finisher controller PCB and sensors normal?	No	Correct the wiring.
Power supply	3	Measure the voltage between J6-2 (+) and J6-4 (-) on the finisher controller PCB. Is it 5 VDC?	No	Replace the finisher controller PCB.
Height sensor (PS1)			Yes	Replace the height sensor.

6. Faulty back-up RAM

Cause	Step	Checks	Yes/No	Action
Finisher controller PCB, punch drive PCB	1	Turn the host machine OFF, then ON. Is the problem corrected?	Yes	End.
	2	Replace the finisher controller PCB and punch driver PCB. Is the problem corrected?	Yes	End.

7. Faulty delivery motor

Cause	Step	Checks	Yes/No	Action
Delivery roller	1	Turn the delivery roller by hand. Does it turn smoothly?	No	Correct mechanical operation.
Delivery motor clock sensor (PI10)	2	Check the delivery motor clock sensor. Is the sensor normal?	No	Replace the sensor.
Finisher controller PCB	3	Does the voltage between J11-4 and J11-5 on the finisher controller PCB change to 24 VDC as soon as the delivery motor starts to rotate?	No	Replace the finisher controller PCB.
			Yes	Check the wiring from the motor to the controller PCB. If normal, replace the motor.

8. Faulty alignment motor

Cause	Step	Checks	Yes/No	Action
Alignment guide home position sensor (PI6)	1	Check the alignment guide home position sensor. Is it normal?	No	Replace the sensor.
Wiring	2	Is the wiring between the finisher controller PCB and the alignment motor normal?	No	Correct the wiring.
Alignment guide	3	Is there any mechanical obstacle in the path of the alignment guide?	Yes	Remove the mechanical obstacle.
Alignment motor (M3)	4	Replace the alignment motor. Is the problem corrected?	Yes	End.
Finisher controller PCB			No	Replace the finisher controller PCB.

9. Faulty staple motor

Cause	Step	Checks	Yes/No	Action
Wiring	1	Is the wiring between the stapler and the finisher controller PCB normal?	No	Correct the wiring.
Stapler	2	Replace the stapler. Is the problem corrected?	Yes	End.
Finisher controller PCB			No	Replace the finisher controller PCB.

10. Faulty stapler shift motor

Cause	Step	Checks	Yes/No	Action
Stapler shift home position sensor (PI7)	1	Check the stapler shift home position sensor. Is the sensor normal?	No	Replace the sensor.
Wiring	2	Is the wiring between the finisher controller PCB and the stapler shift motor normal?	No	Correct the wiring.
Stapler shift base	3	Is there any mechanical obstacle in the path of the stapler shift base?	Yes	Remove the mechanical obstacles.
Stapler shift motor (M4)	4	Replace the stapler motor. Is the problem corrected?	Yes	End
Finisher controller PCB			No	Replace the finisher controller PCB.

11. Faulty swing motor (related to MS6)

Cause	Step	Checks	Yes/No	Action
Swinging mechanism	1	Turn the swing motor in reverse by hand. Does the swing guide move up and down?	No	Correct the swing mechanism.
Swing guide closed detection switch 2 (MS6)	2	Is the swing guide closed detection switch 2 normal?	No	Replace the microswitch.
Swing motor (M7)	3	Does the swing motor rotate in reverse at a specific timing?	No	Replace the motor.
Finisher controller PCB			Yes	Replace the finisher controller PCB.

12. Faulty swing motor (related to PI18)

Cause	Step	Checks	Yes/No	Action
Swinging mechanism	1	Turn the delivery motor in reverse by hand. Does the swing guide move up and down?	No	Correct the swinging mechanism.
Swing guide open sensor (PI18)	2	Is the swing guide open sensor normal?	No	Replace the sensor.
Swing motor (M7)	3	Does the swing motor rotate in reverse at a specific timing?	No	Replace the motor.
Finisher controller PCB			Yes	Replace the finisher controller PCB.

13. Faulty swing motor (related to MS3)

Cause	Step	Checks	Yes/No	Action
Safety range switch (MS3)	1	Check the safety range switch. Is the switch normal?	No	Replace the switch.
	2	Is the safety range detection switch pressed correctly?	No	Correct mechanical operation.
Swing guide closed detection switch 2 (MS6)	3	Check the swing guide closed detection switch 2. Is the switch normal?	No	Replace the switch.
	4	Is the swing guide closed detection switch 2 pressed correctly?	No	Correct mechanical operation.
Finisher controller PCB			Yes	Replace the finisher controller PCB.

14. Faulty swing motor (related to PI20)

Cause	Step	Checks	Yes/No	Action
Swing motor clock sensor (PI20)	1	Check the swing motor clock sensor. Is the sensor normal?	No	Replace the sensor.
Finisher controller PCB	2	Does the voltage of the swing motor between J11-6 and -7 on the finisher controller PCB reach 24 V at a specific rotation timing?	No	Replace the finisher controller PCB.
			Yes	Check the wiring from the motor to the finisher controller PCB. If normal, replace the motor.

15. Faulty tray lift motor (related to PI8)

Cause	Step	Checks	Yes/No	Action
Tray home position sensor (PI8)	1	Check the tray home position sensor. Is it normal?	No	Replace the sensor.
Tray lift mechanism	2	Check the tray lift mechanism. Is the mechanism normal?	No	Correct the mechanism.
Finisher controller PCB	3	Is the tray lift motor supplied with 24 VDC by the finisher controller PCB as soon as the tray is driven?	No	Replace the finisher controller PCB.
Wiring	4	Check the wiring from the finisher controller PCB to the tray lift motor. Is the wiring normal?	No	Correct the wiring.
Tray lift motor (M5)			Yes	Replace the tray lift motor.

16. Faulty tray lift motor (related to MS5)

Cause	Step	Checks	Yes/No	Action
Tray position	1	Is the tray at the tray upper limit switch?	Yes	Lower the tray.
Tray upper limit switch (MS5)	2	Check the tray upper limit switch. Is the switch normal?	No	Replace the switch.
Wiring	3	Check the wiring from the finisher controller PCB to the tray upper limit switch. Is the wiring normal?	No	Correct the wiring.
Finisher controller PCB			Yes	Replace the finisher controller PCB.

17. Faulty tray motor (related to PI9, PI19)

Cause	Step	Checks	Yes/No	Action
—	1	Does the tray move up/down?	No	Go to step 2.
			Yes	Go to step 4.
Finisher controller PCB	2	Is the motor supplied with power by the finisher controller PCB as soon as the tray moves up/down?	Yes	Go to step 3.
			No	Replace the finisher controller PCB.
Tray lift mechanism	3	Is there a fault in the tray lift mechanism?	Yes	Correct the tray lift mechanism.
Tray lift motor (M5)			No	Replace the tray lift motor.
Tray lift motor clock sensor 1/2 (PI9/19)	4	Is the tray lift motor clock sensor 1/2 normal?	No	Replace the sensor PCB.
Finisher controller PCB			Yes	Replace the finisher controller PCB.

18. Faulty second feed motor (related to PI5)

Cause	Step	Checks	Yes/No	Action
Second feed motor (M8)	1	Does the second feed motor rotate in reverse at a specific timing?	No	Replace the second feed motor or the finisher controller PCB.
Shutter mechanism	2	Are the shutter and the shutter upper/lower bar engaged correctly?	No	Engage them correctly.
	3	Turn feed roller 2 in reverse by hand. Does the shutter upper/lower bar move up/down?	No	Correct mechanism from the shutter upper/lower bar to the gear of feed roller 2.
Shutter open detection sensor (PI5)	4	Is the shutter open detection sensor normal?	No	Replace the sensor.
Finisher controller PCB			Yes	Replace the finisher controller PCB.

19. Faulty second feed motor (related to MS4)

Cause	Step	Checks	Yes/No	Action
Second feed motor (M8)	1	Does the second feed motor rotate in reverse at a specific timing?	No	Replace the second feed motor or the finisher controller PCB.
Shutter mechanism	2	Are the shutter and the shutter upper/lower bar engaged correctly?	No	Engage them correctly.
	3	Turn feed roller 2 in reverse by hand. Does the shutter upper/lower bar move up/down?	No	Correct the mechanism from the shutter upper/lower bar to the gear of feed roller 2.
Shutter closed detection switch (MS4)	4	Is the shutter closed detection switch normal?	No	Replace the switch.
Finisher controller PCB			Yes	Replace the finisher controller PCB.

20. Faulty second feed motor (related to MS3)

Cause	Step	Checks	Yes/No	Action
Safety range switch (MS3)	1	Check the safety range switch. Is the switch normal?	No	Replace the switch.
	2	Is the safety range detection switch passed correctly?	No	Correct mechanical operation.
Shutter closed detection switch (MS4)	3	Check the shutter closed detection switch. Is the switch normal?	No	Replace the switch.
	4	Is the shutter closed detection switch pressed correctly?	No	Correct the mechanism.
Yes			Replace the finisher controller PCB.	
Finisher controller PCB				

B. Saddle Stitcher Unit

1. Faulty paper positioning plate

Cause	Step	Checks	Yes/No	Action
Paper positioning plate home position sensor (PI7S)	1	Check the paper positioning plate home position sensor. Is the sensor normal?	No	Replace the sensor.
Saddle stitcher controller PCB	2	Do the paper positioning plates operate at a specific timing?	Yes	Replace the saddle stitcher controller PCB.
Paper positioning plate motor (M4S)			No	Check the positioning plate drive mechanism. If a fault is found, correct it. Otherwise, go to step 3.
Saddle stitcher controller PCB	3	Replace the paper positioning plate motor. Is the problem corrected?	Yes	End.
			No	Replace the saddle stitcher controller PCB.

2. Faulty paper folding motor

Cause	Step	Checks	Yes/No	Action
Paper folding motor clock sensor (PI4S)	1	Check the paper folding motor clock sensor. Is the sensor normal?	No	Replace the sensor.
Paper folding home position sensor (PI21S)	2	Check the paper folding home position sensor. Is the sensor normal?	No	Replace the sensor.
Saddle stitcher controller PCB	3	Does the paper folding motor operate at a specific timing?	Yes	Replace the saddle stitcher controller PCB.
Paper folding motor (M2S)			No	Check the paper folding roller drive mechanism. If a fault is found, correct it. Otherwise, go to step 4.
			4	Replace the paper folding motor. Is the problem corrected?
Saddle stitcher controller PCB			No	Replace the saddle stitcher controller PCB.

3. Faulty guide motor

Cause	Step	Checks	Yes/No	Action
Guide home position sensor (PI13S)	1	Check the guide home position sensor. Is the sensor normal?	No	Replace the sensor.
Saddle stitcher controller PCB	2	Does the guide motor operate at a specific timing?	Yes	Replace the saddle stitcher controller PCB.
Guide motor (M3S)			No	Check the guide plate drive mechanism. If a fault is found, correct it. Otherwise, go to step 3.
	3	Replace the guide motor. Is the problem corrected?	Yes	End.
Saddle stitcher controller PCB			No	Replace the saddle stitcher controller PCB.

4. Faulty alignment motor

Cause	Step	Checks	Yes/No	Action
Alignment plate home position sensor (PI5S)	1	Check the alignment plate home position sensor. Is the sensor normal?	No	Replace the sensor.
Saddle stitcher controller PCB	2	Does the alignment motor operate at a specific timing?	Yes	Replace the saddle stitcher controller PCB.
Alignment motor (M5S)			No	Check the alignment plate drive mechanism. If a fault is found, correct it. Otherwise, go to step 3.
	3	Replace the alignment motor. Is the problem corrected?	Yes	End.
Saddle stitcher controller PCB			No	Replace the saddle stitcher controller PCB.

5. Faulty stitcher

Cause	Step	Checks	Yes/No	Action
Stitcher (installation)	1	Are the front and rear stitchers and bases installed correctly?	No	Install them correctly.
Stitching home position switch (MS7S/MS5S)	2	Is the stitching home position switch of the front and the rear stitchers normal?	No	Replace the front or rear stitcher.
Saddle stitcher controller PCB	3	Do the front and the rear stitchers operate at a specific timing?	Yes	Check the wiring between the stitcher and the saddle stitcher controller PCB. If normal, replace the controller PCB.
Stitcher motor (M7S/M6S)			No	Replace the front or the rear stitcher.

6. Faulty paper pushing plate motor (related to PI14S)

Cause	Step	Checks	Yes/No	Action
Paper pushing plate home position sensor (PI14S)	1	Check the paper pushing plate home position sensor. Is the sensor normal?	No	Replace the sensor.
Saddle stitcher controller PCB	2	Does the paper pushing plate motor operate at a specific timing?	Yes	Replace the saddle stitcher controller PCB
Paper pushing plate motor (M8S)			No	Check the paper pushing plate drive mechanisms. If a fault is found, correct it. Otherwise, go to step 3.
Saddle stitcher controller PCB	3	Replace the paper pushing plate motor. Is the problem corrected?	Yes	End.
			No	Replace the saddle stitcher controller PCB.

7. Faulty paper pushing plate motor (related to PI15S)

Cause	Step	Checks	Yes/No	Action
Paper pushing top position sensor (PI15S)	1	Check the paper pushing plate top position sensor. Is the sensor normal?	No	Replace the sensor.
Saddle stitcher controller PCB	2	Does the paper pushing plate motor operate at a specific timing?	Yes	Replace the saddle stitcher controller PCB.
Paper pushing plate motor (M8S)			No	Check the paper pushing plate drive mechanism. If a fault is found, correct it. Otherwise, go to step 3.
Saddle stitcher controller PCB	3	Replace the paper pushing plate motor. Is the problem corrected?	Yes	End.
			No	Replace the saddle stitcher controller PCB.

8. Faulty paper pushing plate motor (related to PI1S)

Cause	Step	Checks	Yes/No	Action
Paper pushing plate motor clock sensor (PI1S)	1	Check the paper pushing plate motor clock sensor. Is the sensor normal?	No	Replace the sensor.
Saddle stitcher controller PCB	2	Does the paper pushing plate motor operate at a specific timing?	Yes	Replace the saddle stitcher controller PCB.
Paper pushing plate motor (M8S)			No	Check the paper pushing plate drive mechanism. If a fault is found, correct it. Otherwise, go to step 3.
Saddle stitcher controller PCB	3	Replace the paper pushing plate motor. Is the problem corrected?	Yes	End.
			No	Replace the saddle stitcher controller PCB.

9. Disconnected sensor connector (related to PI13S)

Cause	Step	Checks	Yes/No	Action
Guide home position sensor (PI13S; disconnected)	1	Are the connectors of the guide home position sensor and the saddle stitcher controller PCB connected correctly?	No	Connect the connectors.
Wiring	2	Is the wiring between the sensor and the saddle stitcher broken?	Yes	Correct the wiring.
Power supply	3	Is 5 VDC present at J9-7 on the saddle stitcher controller PCB?	No	Replace the saddle stitcher controller PCB.
Ground	4	Is J9-8 on the saddle stitcher controller PCB grounded correctly?	No	

10. Disconnected sensor connector (related to PI14S)

Cause	Step	Checks	Yes/No	Action
Paper pushing plate home position sensor (PI14S; disconnected)	1	Are the connectors of the paper pushing plate home position sensor and the saddle stitcher controller PCB connected correctly?	No	Connect the connectors.
Wiring	2	Is the wiring between the sensor and the saddle stitcher broken?	Yes	Correct the wiring.
Power supply	3	Is 5 VDC present at J9-10 on the saddle stitcher controller PCB?	No	Replace the saddle stitcher controller PCB.
Ground	4	Is J9-11 on the saddle stitcher controller PCB grounded correctly?	No	

11. Disconnected sensor connector (related to PI15S)

Cause	Step	Checks	Yes/No	Action
Paper pushing plate home position top position sensor (PI15S; disconnected)	1	Are the connectors of the paper pushing plate top position sensor and the saddle stitcher controller PCB connected correctly?	No	Connect the connectors.
Wiring	2	Is the wiring between the sensor and the saddle stitcher broken?	Yes	Correct the wiring.
Power supply	3	Is 5 VDC present at J9-13 on the saddle stitcher controller PCB?	No	Replace the saddle stitcher controller PCB.
Ground	4	Is J9-14 on the saddle stitcher controller PCB grounded correctly?	No	

12. Faulty microswitch (related to MS1S)

Cause	Step	Checks	Yes/No	Action
Switch actuator	1	Check the switch actuator of the inlet door. Do the switch and the sensor operate correctly?	No	Correct the mechanism.
Inlet door switch (MS1S)	2	Check the inlet door switch. Is the switch normal?	No	Replace the switch.
Inlet cover sensor (PI9S)	3	Measure the voltage at J10-8 on the saddle stitcher controller PCB with the inlet cover open. Is it 5 V?	Yes	The sensor is faulty. Replace the sensor.
Power supply, wiring	4	Measure the voltage between J19-1 (+) and J19-2 (-) on the finisher controller PCB. Is it 24 V?	No	Replace the finisher controller PCB.
			Yes	Check the wiring between J19 on the finisher controller PCB and J1 on the saddle stitcher controller PCB. If a fault is found, correct it. Otherwise, replace the saddle stitcher controller PCB.

13. Faulty microswitch (related to MS2S)

Cause	Step	Checks	Yes/No	Action
Switch actuator	1	Check the switch actuator of the front door. Do the switch and the sensor operate correctly?	No	Correct the mechanism.
Front door switch (MS2S)	2	Check the front door switch. Is the switch normal?	No	Replace the switch.
Front door open/closed sensor (PI12S)	3	Measure the voltage at J11-12 on the saddle stitcher controller PCB with the front door open. Is it 5 V?	Yes	The sensor is faulty. Replace the sensor.
			No	Replace the saddle stitcher controller PCB.

14. Faulty microswitch (related to MS3S)

Cause	Step	Checks	Yes/No	Action
Switch actuator	1	Check the delivery door switch actuator. Do the switch and the sensor operate correctly?	No	Correct the mechanism.
Delivery switch (MS3S)	2	Check the delivery door switch. Is the switch normal?	No	Replace the switch.
Delivery cover sensor (PI3S)	3	Measure the voltage at J11-9 on the saddle stitcher controller PCB with the delivery door open. Is it 5 V?	Yes	The sensor is faulty. Replace the sensor.
			No	Replace the saddle stitcher controller PCB.

C. Puncher Unit (option)

1. Faulty punch motor

Cause	Step	Checks	Yes/No	Action
Punch motor clock sensor (PI2P)	1	Check the punch motor clock sensor. Is the sensor normal?	No	Replace the sensor.
Punch home position sensor (PI3P)	2	Check the punch home position sensor. Is the sensor normal?	No	Replace the sensor.
Wiring	3	Is the wiring between the punch home position sensor and the finisher controller PCB normal?	No	Correct the wiring.
Punch mechanism	4	Is there any trouble with the punch mechanism?	Yes	Correct the punch mechanism.
Punch motor (M1P)			No	Replace the punch motor.
Punch driver PCB	5	Replace the punch driver PCB. Is the problem corrected?	No	Replace the finisher controller PCB.
			Yes	End.

2. Faulty horizontal registration motor

Cause	Step	Checks	Yes/No	Action
Horizontal registration home position sensor (PI1P)	1	Check the horizontal registration home position sensor. Is the sensor normal?	No	Replace the sensor.
Wiring	2	Is the wiring between the horizontal registration home position sensor and the finisher controller PCB normal?	No	Correct the wiring.
Horizontal registration mechanism	3	Is there any problem with the horizontal registration mechanism?	Yes	Correct the horizontal registration mechanism.
Horizontal registration motor (M2P)			No	Replace the horizontal registration motor.
Punch driver PCB	4	Replace the punch driver PCB. Is the problem corrected?	No	Replace the finisher controller PCB.
			Yes	End.

APPENDIX

A. SIGNAL AND ABBREVIATIONS	A-1	E. SADDLE STITCHER UNIT PCB	A-17
B. FINISHER UNIT CIRCUIT DIAGRAM	A-2	F. PUNCHER UNIT (OPTION) CIRCUIT DIAGRAM.....	A-25
C. FINISHER CONTROLLER PCB	A-5	G. PUNCH DRIVER PCB	A-26
D. SADDLE STITCHER UNIT CIRCUIT DIAGRAM	A-15	H. SOLVENT AND OIL	A-28

A. SIGNAL AND ABBREVIATIONS

The following presents the abbreviations of signals used in this manual and in drawings, and the meanings of each signal.

Reference:

Signals enclosed by brackets [] are electrical signals. However, the state “1” or “0” of these analog signals cannot be indicated. Otherwise, the state of digital signals “1” or “0” can be indicated.

Finisher unit

BESCPSL	BELT ESCAPE SOLENOID DRIVE Signal
BUFENTR	BUFFER PATH INLET PAPER DETECT Signal
BUFPASS	BUFFER PATH PAPER DETECT Signal
CRTSET	CARTRIDGE DETECT Signal
DELCLK	DELIVERY MOTOR CLOCK DETECT Signal
DROPN	DOOR OPEN DETECT Signal
DRSW	DOOR SWITCH Signal
ENTSL	BUFFER INLET SOLENOID DRIVE Signal
ESCPSL	ESCAPE SOLENOID DRIVE Signal
EXITSL	BUFFER OUTLET SOLENOID DRIVE Signal
FLPSL	FLAPPER SOLENOID DRIVE Signal
FSTTRAY	TRAY 1 PAPER DETECT Signal
HOOKEMP	HOOK EMPTY DETECT Signal
HOOKTOP	HOOK STOP POSITION DETECT Signal
JOGHP	ALIGNMENT PLATE HP DETECT Signal
JOINT	JOINT DETECT Signal
PDEL	DELIVERY DETECT Signal
PDLSL	PADDLE SOLENOID DRIVE Signal
PENT	INLET PAPER DETECT Signal
SFTCLK1	SHIFT MOTOR CLOCK DETECT Signal 1
SFTCLK2	SHIFT MOTOR CLOCK DETECT Signal 2
SHUTCLD	SHUTTER CLOSED DETECT SWITCH Signal
SNDTRAY	TRAY 2 PAPER DETECT Signal
STOPN	SHUTTER OPEN DETECT Signal
STPCON	STAPLER CONNECT DETECT Signal
STPDRHP	STAPLER DRIVE HP DETECT Signal
STPHP	STAPLER HP DETECT Signal
STPTY	STAPLE TRAY PAPER DETECT Signal
SWGCLK	SWING GUIDE CLOCK DETECT Signal
SWGGLD	SWING GUIDE CLOSED DETECT SWITCH Signal
SWGOPN	SWING GUIDE OPEN DETECT Signal
TRAYSAF	TRAY SAFETY SWITCH Signal
TRYHP	TRAY HOME POSITION DETECT Signal
TRYLIM	TRAY UPPER LIMIT DETECTING SWITCH Signal

Saddle stitcher unit

1STPA	No.1 PAPER SENSOR DETECT Signal
2NDPA	No.2 PAPER SENSOR DETECT Signal
3RDDPA	No.3 PAPER SENSOR DETECT Signal
DELV	DELIVERY DETECT Signal
DELVMS	DELIVERY COVER OPEN DETECT SWITCH Signal
EJCVR	DELIVERY COVER OPEN DETECT Signal

FDR	FRONT COVER OPEN DETECT Signal
FDRLHP	CRESCENT ROLLER PHASE DETECT Signal
FDROPN	FRONT COVER OPEN DETECT SWITCH Signal
FLDCLK	FOLD MOTOR CLOCK Signal
FLPSL1	FLAPPER DRIVE Signal 1
FLPSL2	FLAPPER DRIVE Signal 2
GIDHP	PAPER GUIDE HOME POSITION DETECT Signal
HKEMP1	HOOK EMPTY DETECT Signal 1
HKEMP2	HOOK EMPTY DETECT Signal 2
INLTCVR	INLET COVER OPEN DETECT Signal
INLTCVRMS	INLET COVER OPEN SWITCH Signal
JOGHP	ALIGNMENT HP DETECT Signal
LUNGECLK	LUNGE MOTOR CLOCK Signal
LUNGEHP	LUNGE HOME POSITION DETECT Signal
LUNGETOP	LUNGE TOP POSITION DETECT Signal
PAFLDHP	PAPER FOLD HOME POSITION DETECT Signal
PAPPOS	PAPER POSITION PLATE HP DETECT Signal
PPOSPAR	PAPER POSITIONING GUIDE PAPER DETECT Signal
RLNIPSL	FEED PLATE CONTACT SOLENOID DRIVE Signal
STCHHP1	STITCHING HP DETECT Signal 1
STCHHP2	STITCHING HP DETECT Signal 2
STPLHP	STITCHER IN DETECT Signal
TRYPAR	TRAY PAPER DETECT Signal
VPJM	VERTICAL PATH PAPER DETECT Signal

Puncher unit (option)

DFULL	DUST FULL DETECT Signal
FDROPN	FRONT DOOR OPEN DETECT SWITCH Signal
LEDON	LED ON Signal
LEDON1	LED1 ON Signal
LEDON2	LED2 ON Signal
LEDON3	LED3 ON Signal
LEDON4	LED4 ON Signal
LEDON5	LED5 ON Signal
PAEND	PAPER END DETECT Signal
PUNCHHP	PUNCH HOME POSITION DETECT Signal
PUNCHCLK	PUNCH MOTOR CLOCK DETECT Signal
SREG1	SIDE REGISTRATION DETECT Signal 1
SREG2	SIDE REGISTRATION DETECT Signal 2
SREG3	SIDE REGISTRATION DETECT Signal 3
SREG4	SIDE REGISTRATION DETECT Signal 4
SREGHP	SIDE REGISTRATION HOME POSITION DETECT Signal
UDROPN	UPPER DOOR OPEN DETECT SWITCH Signal

B. FINISHER UNIT CIRCUIT DIAGRAM (1/3)

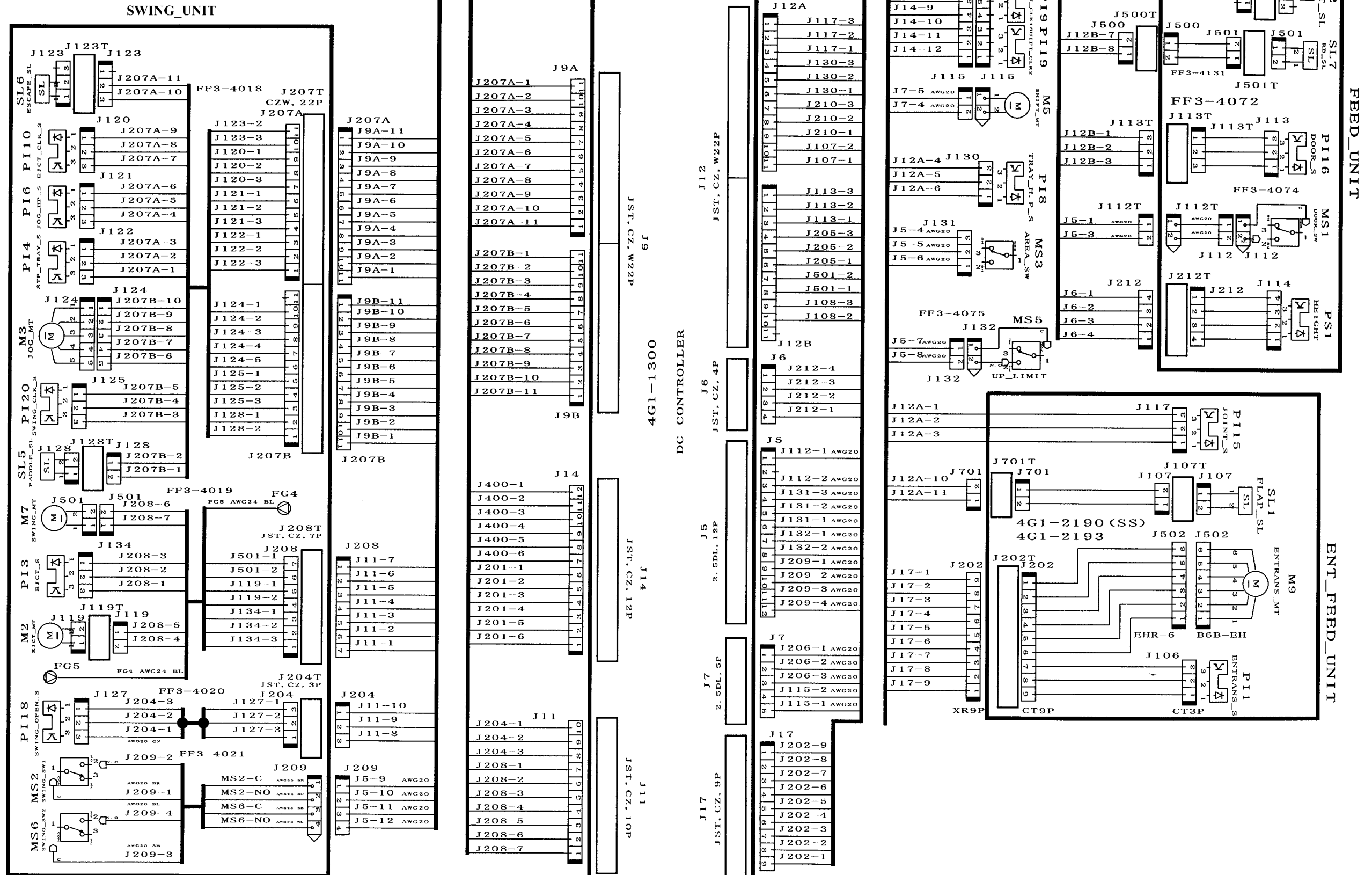

FINISHER UNIT CIRCUIT DIAGRAM (2/3)

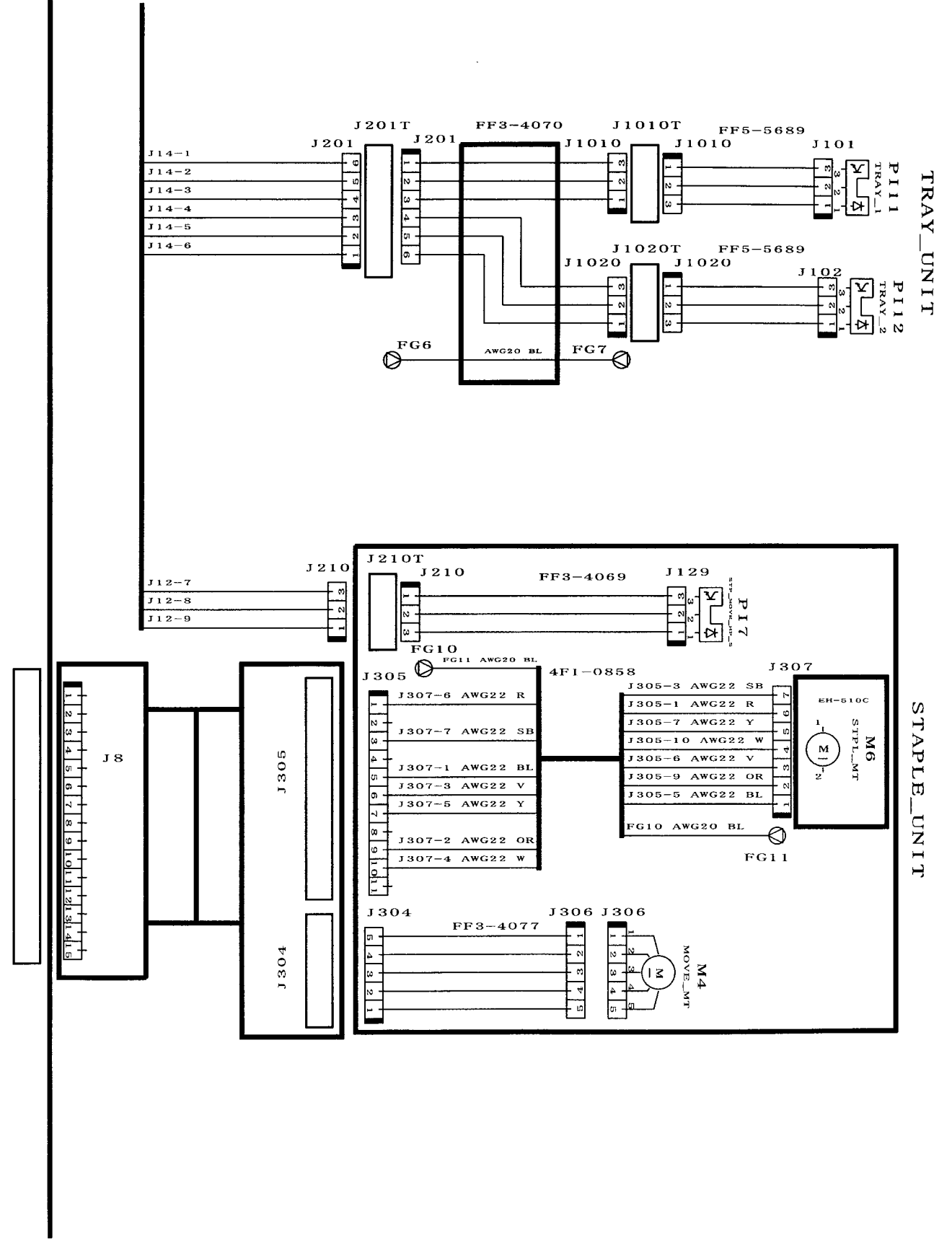
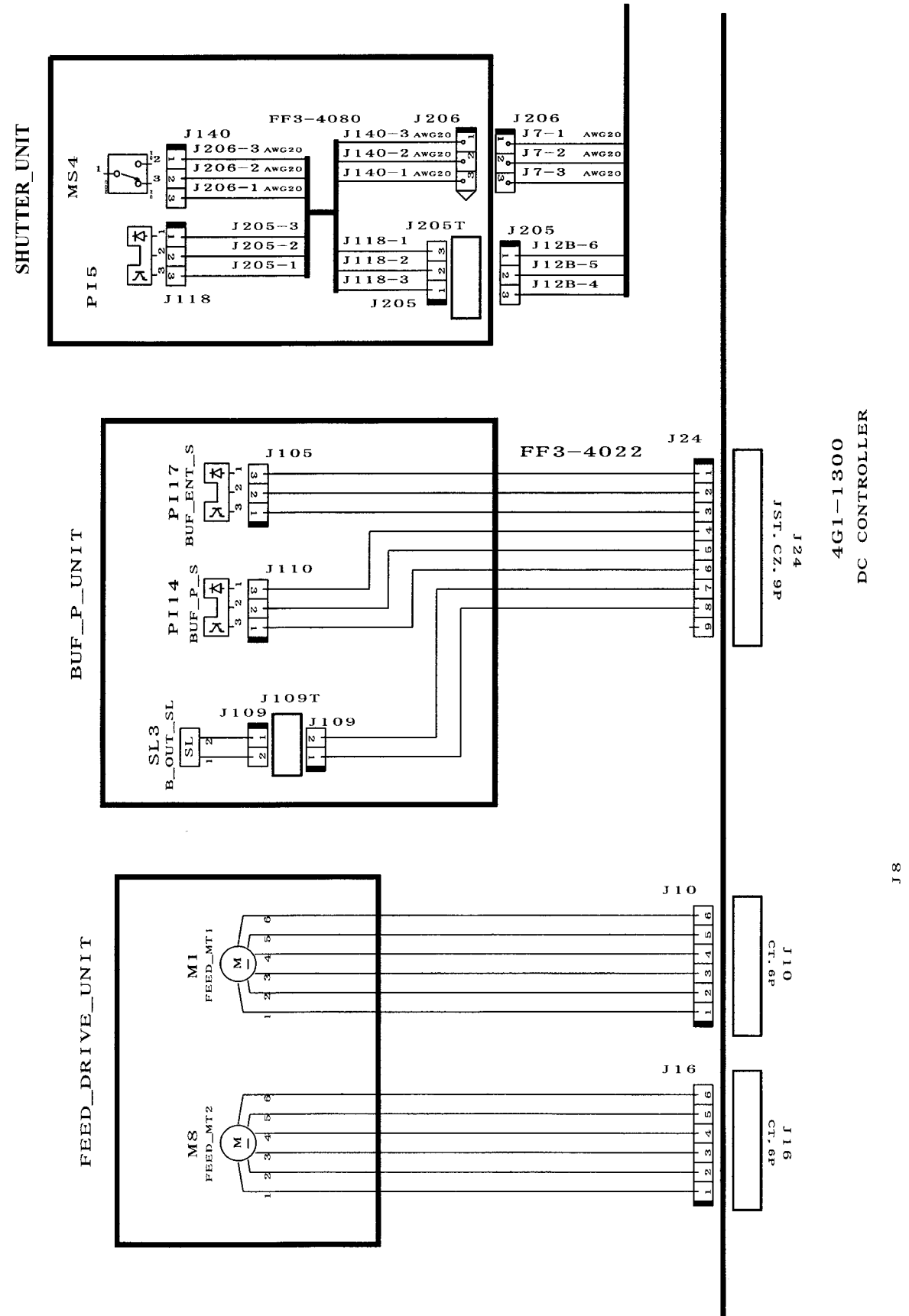

FINISHER UNIT CIRCUIT DIAGRAM (3/3)

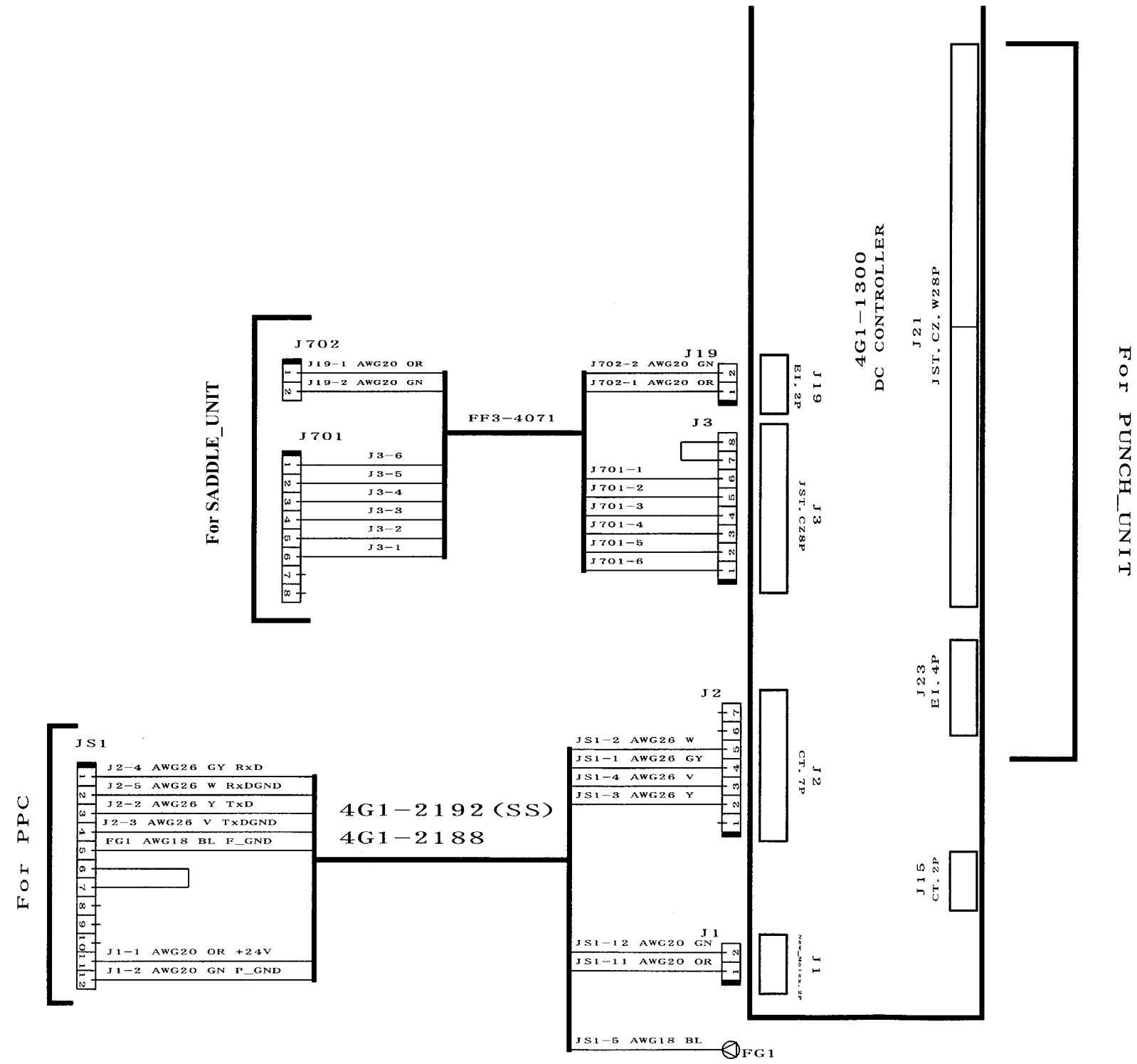

C. FINISHER CONTROLLER PCB (1/10)

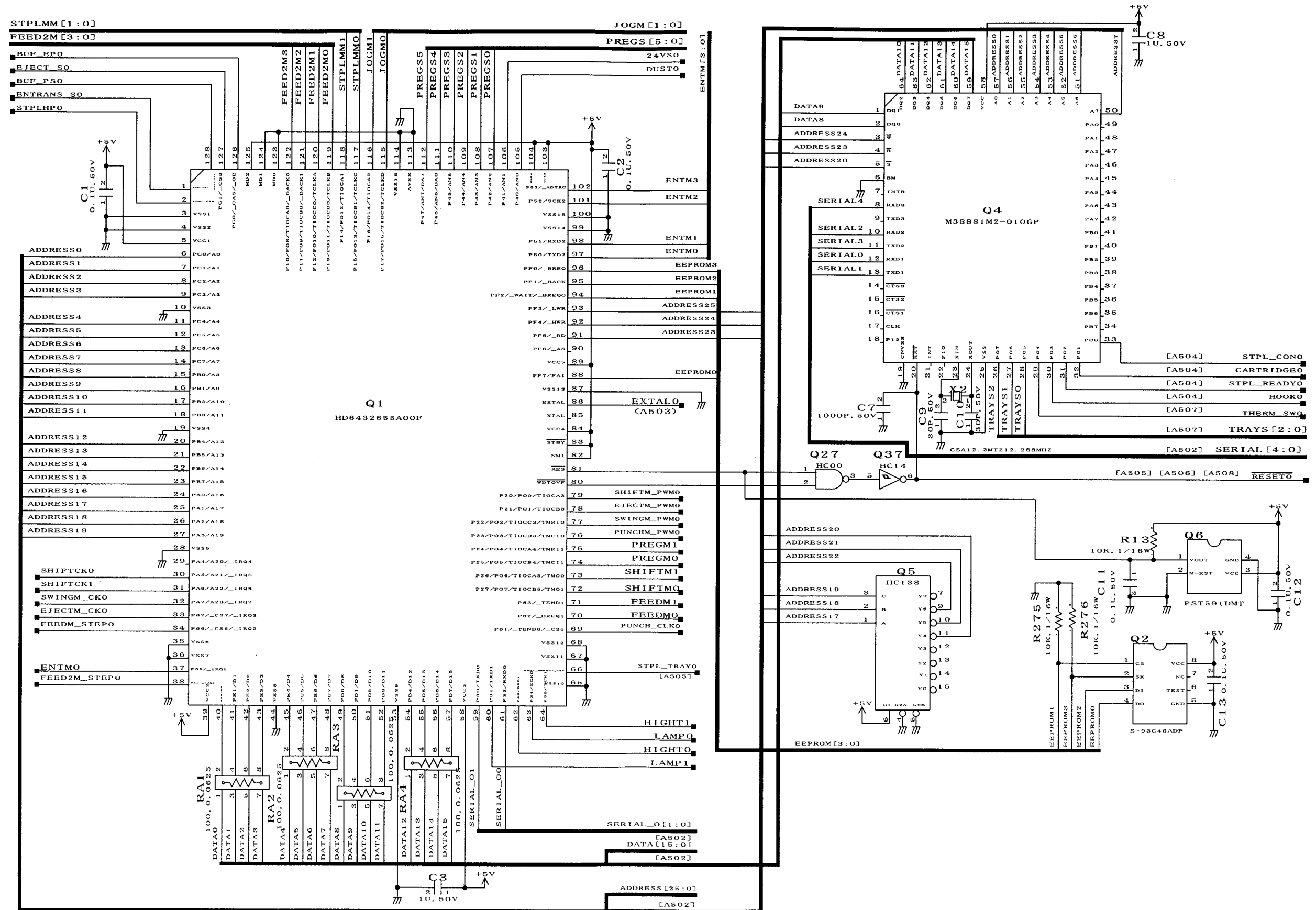

FINISHER CONTROLLER PCB (2/10)

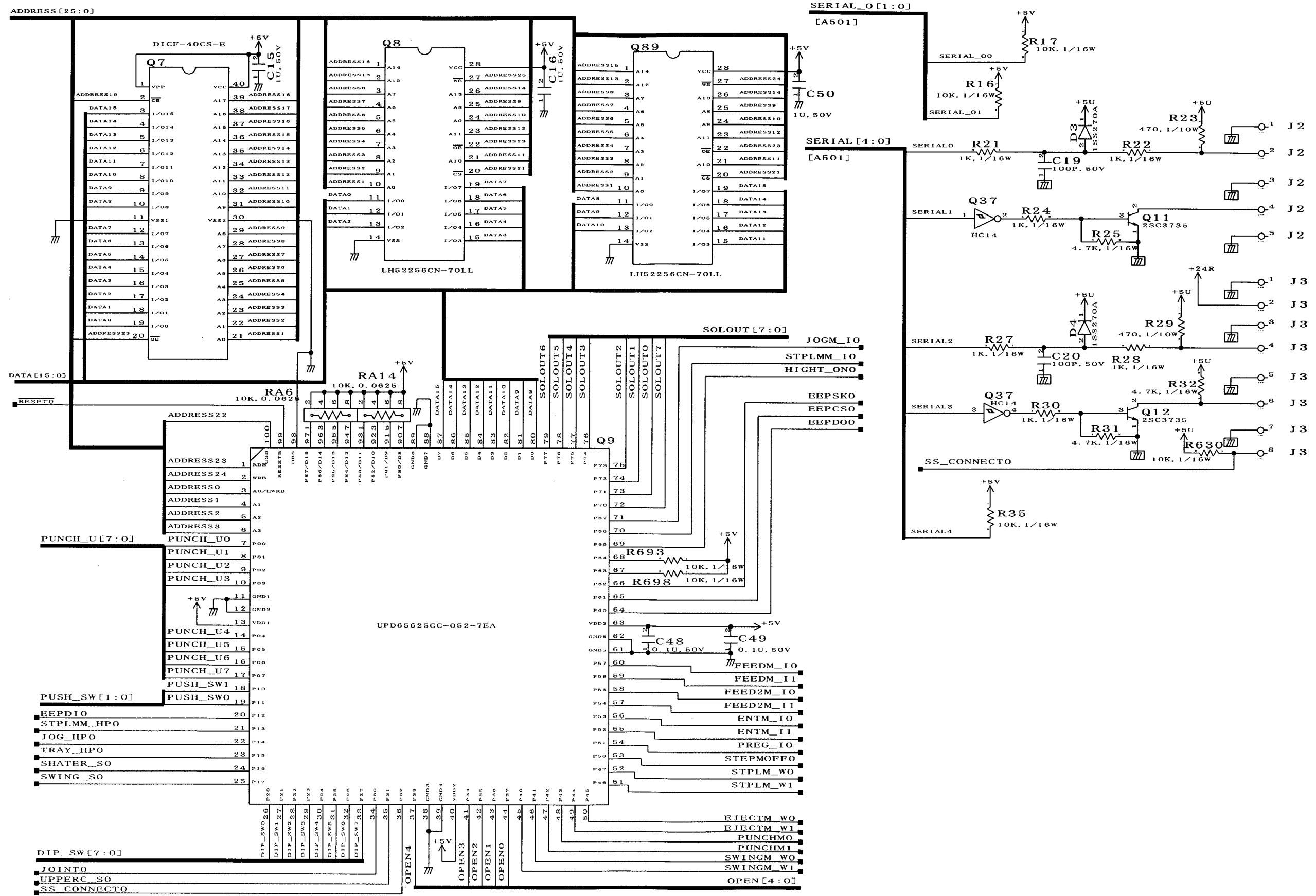

FINISHER CONTROLLER PCB (3/10)

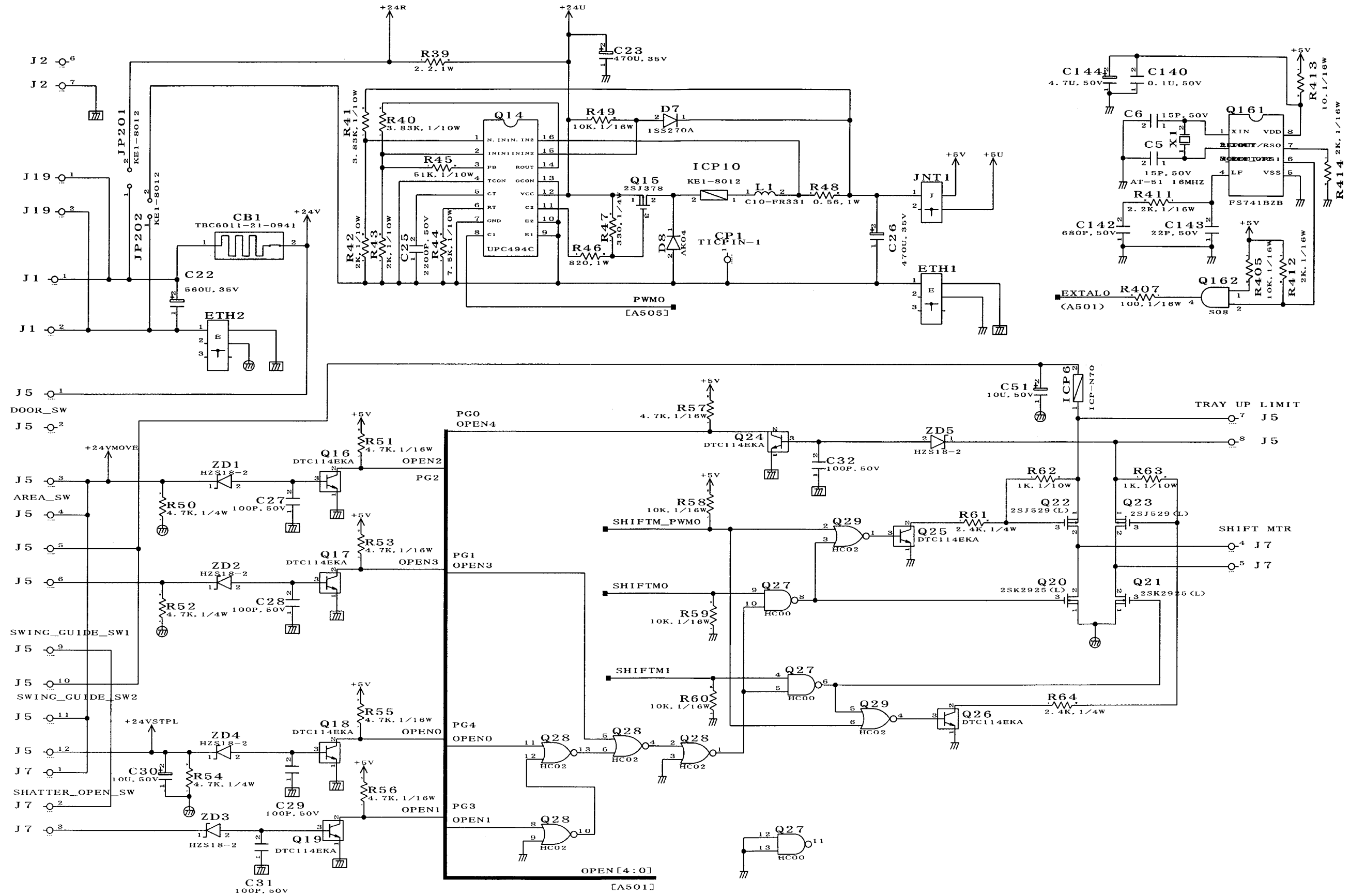

FINISHER CONTROLLER PCB (4/10)

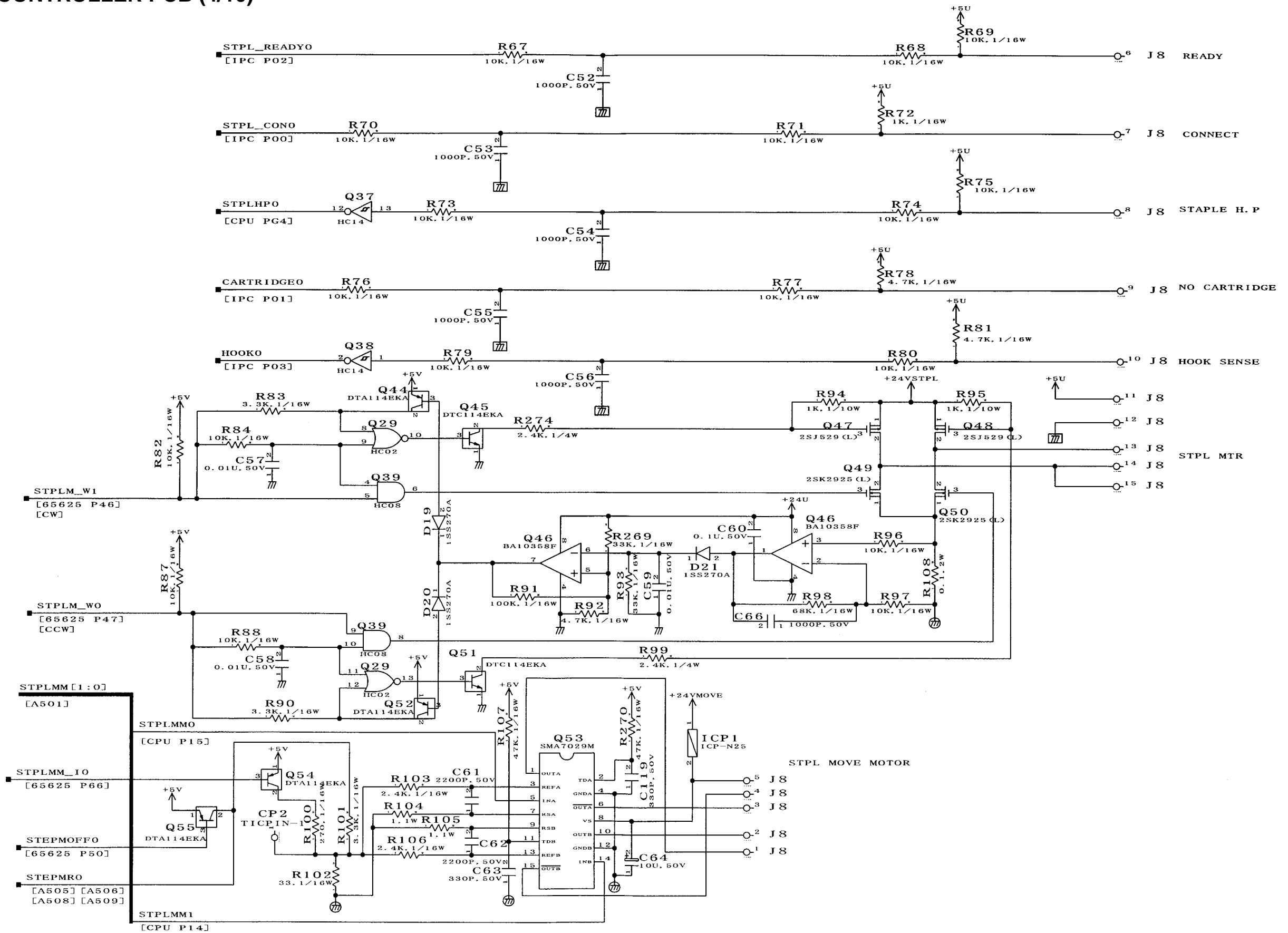

FINISHER CONTROLLER PCB (5/10)

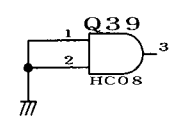
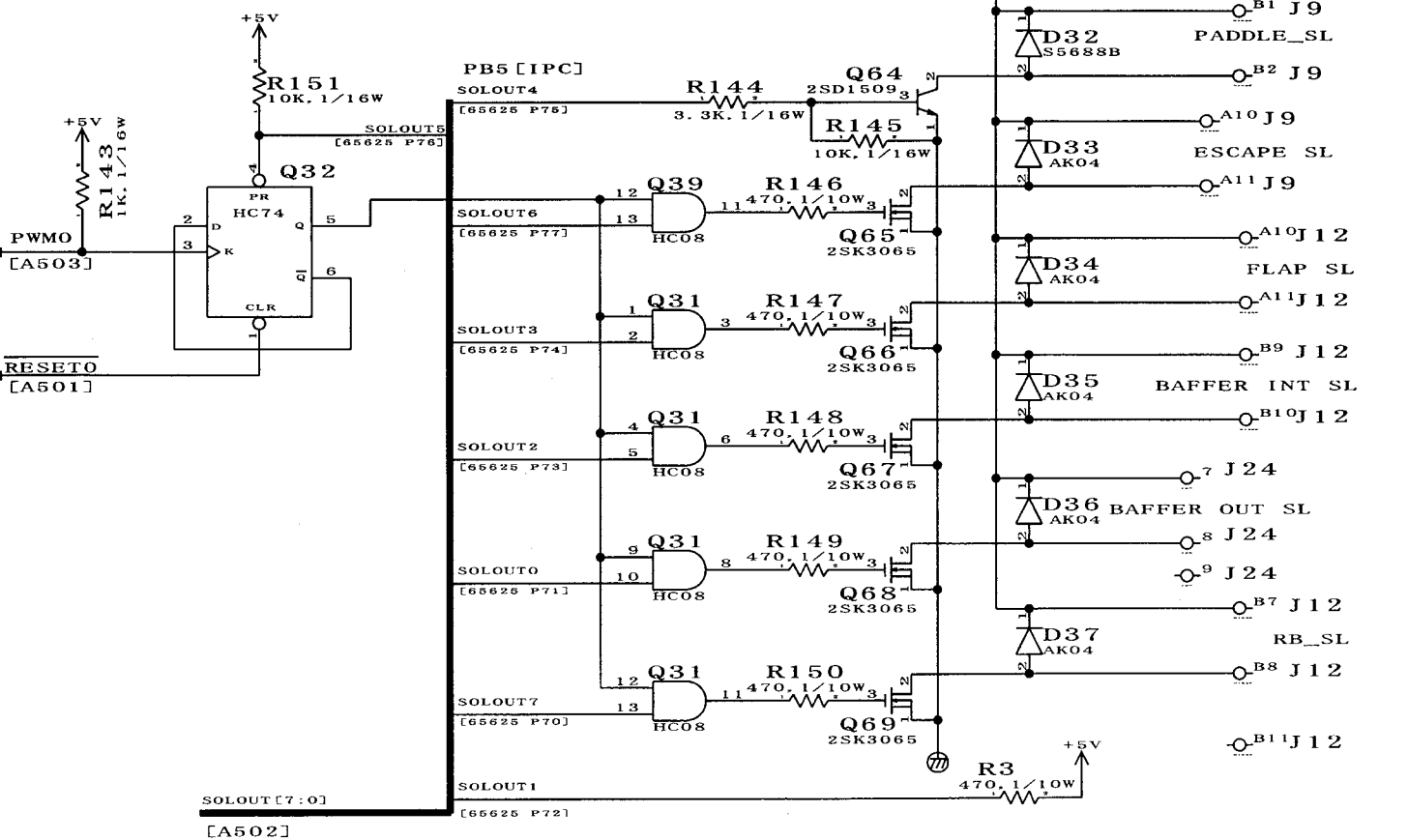
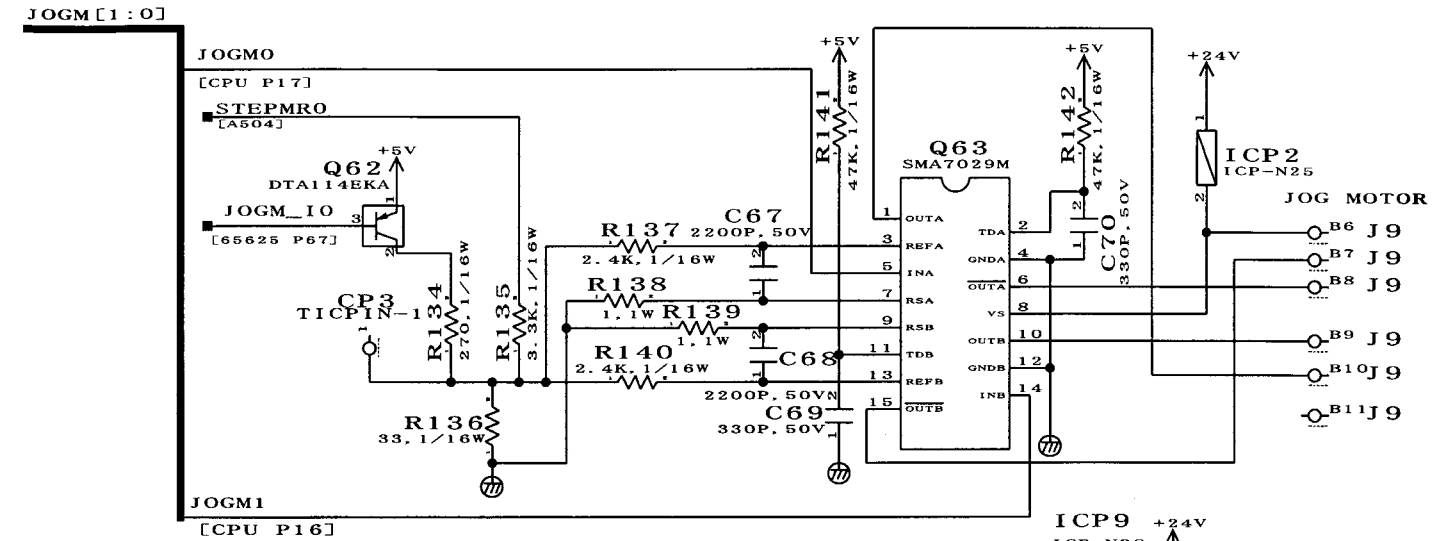
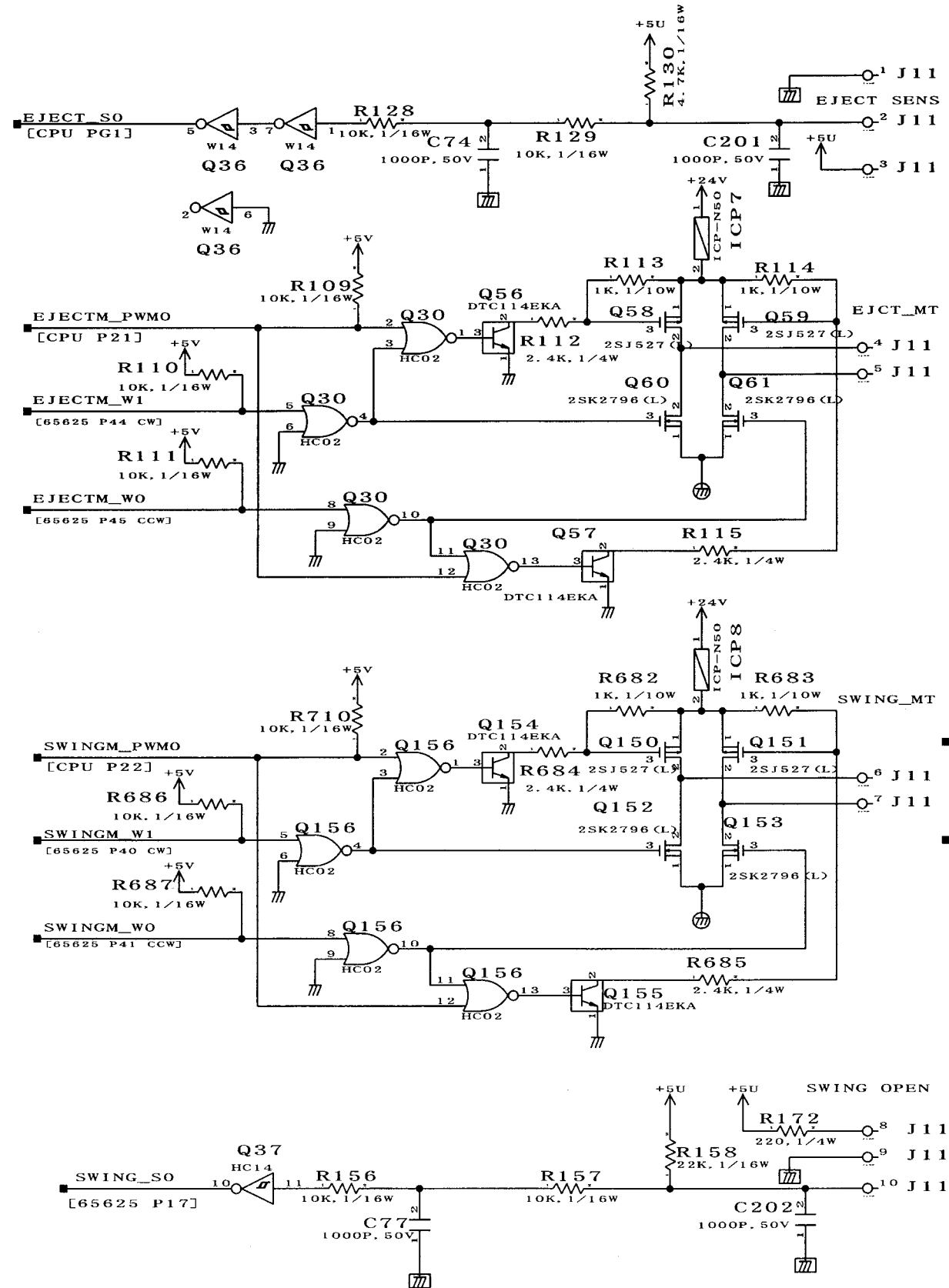

FINISHER CONTROLLER PCB (6/10)

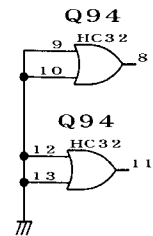
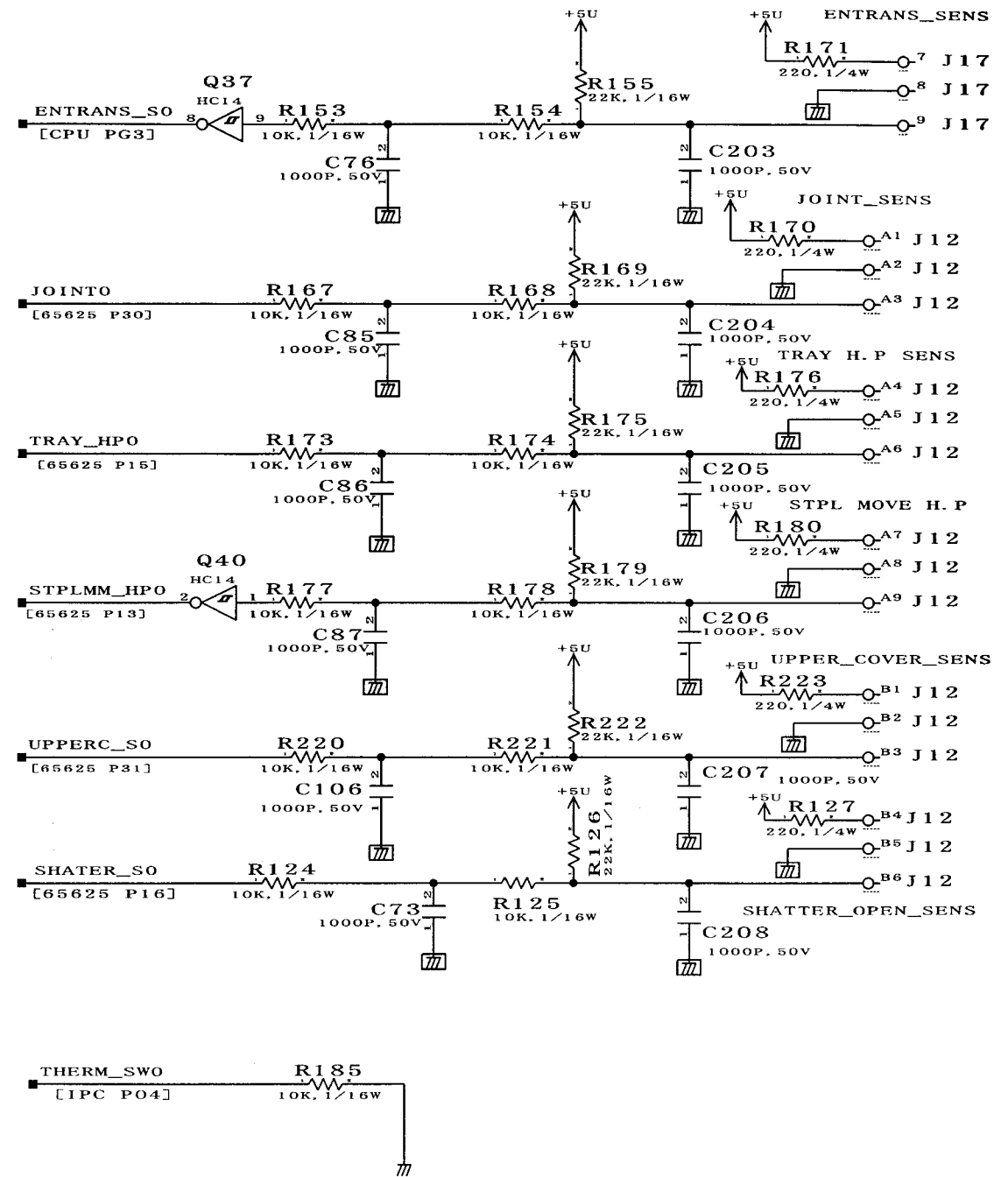
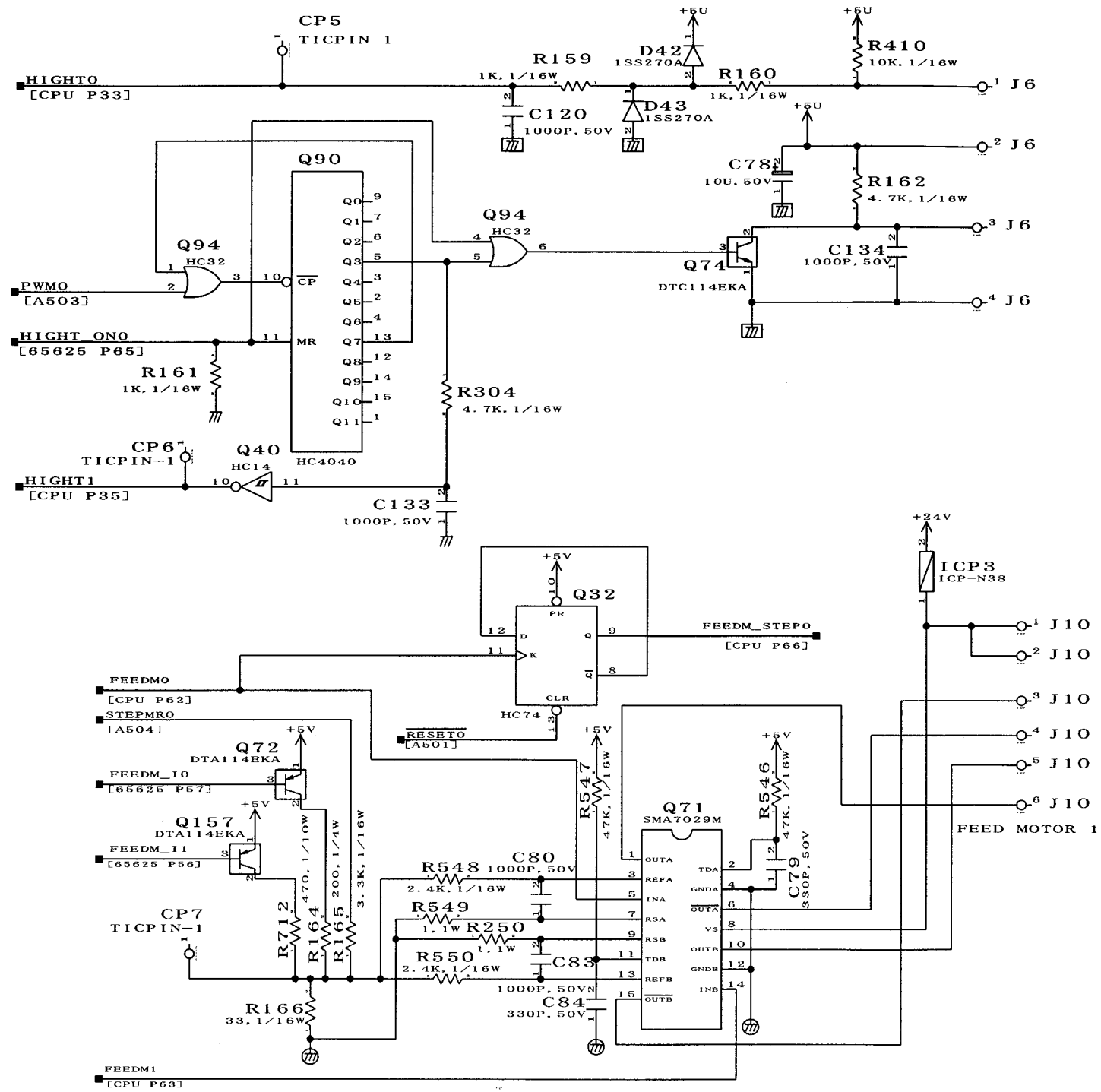

FINISHER CONTROLLER PCB (7/10)

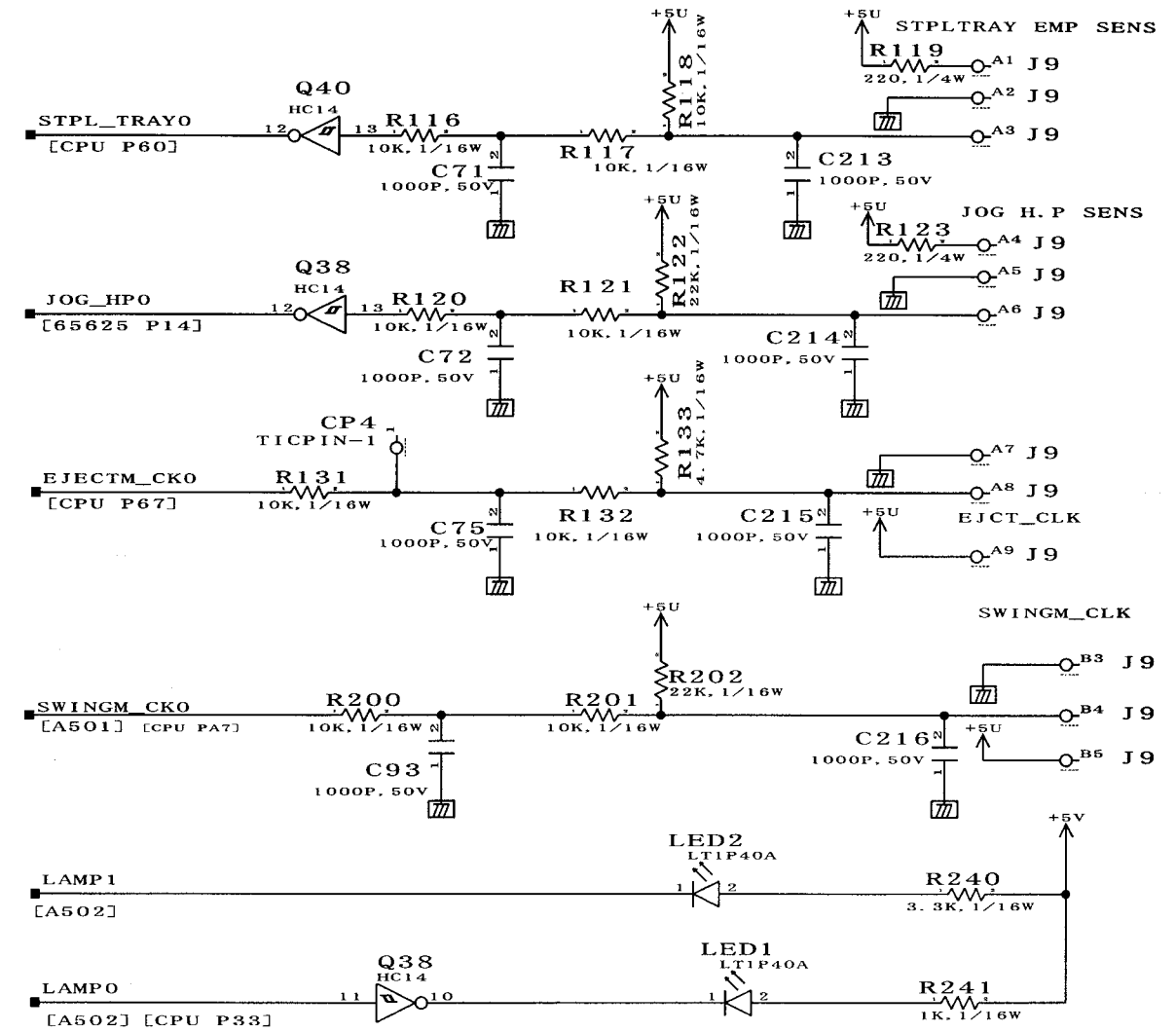
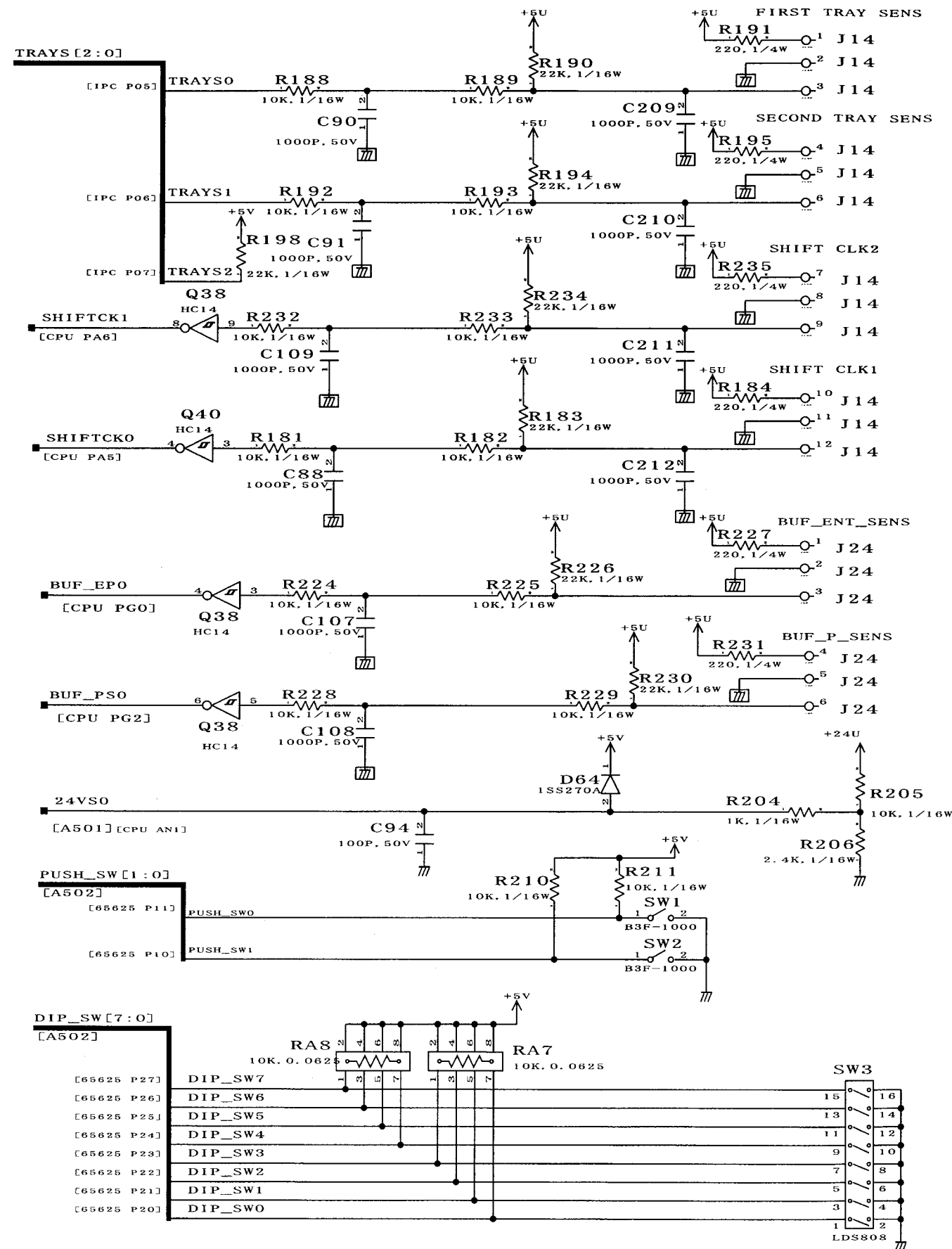

FINISHER CONTROLLER PCB (8/10)

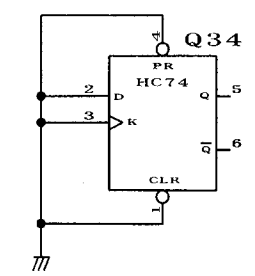
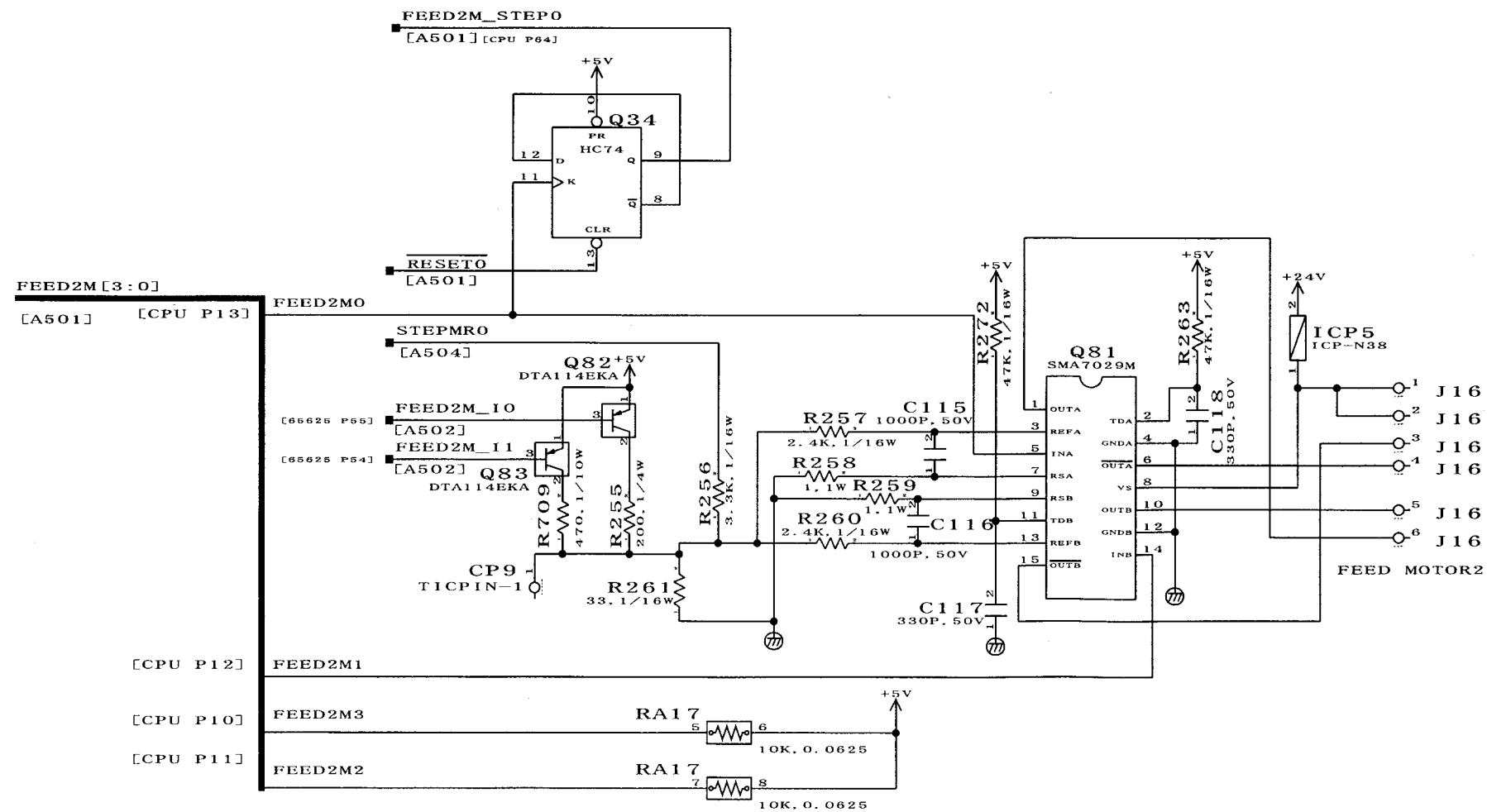
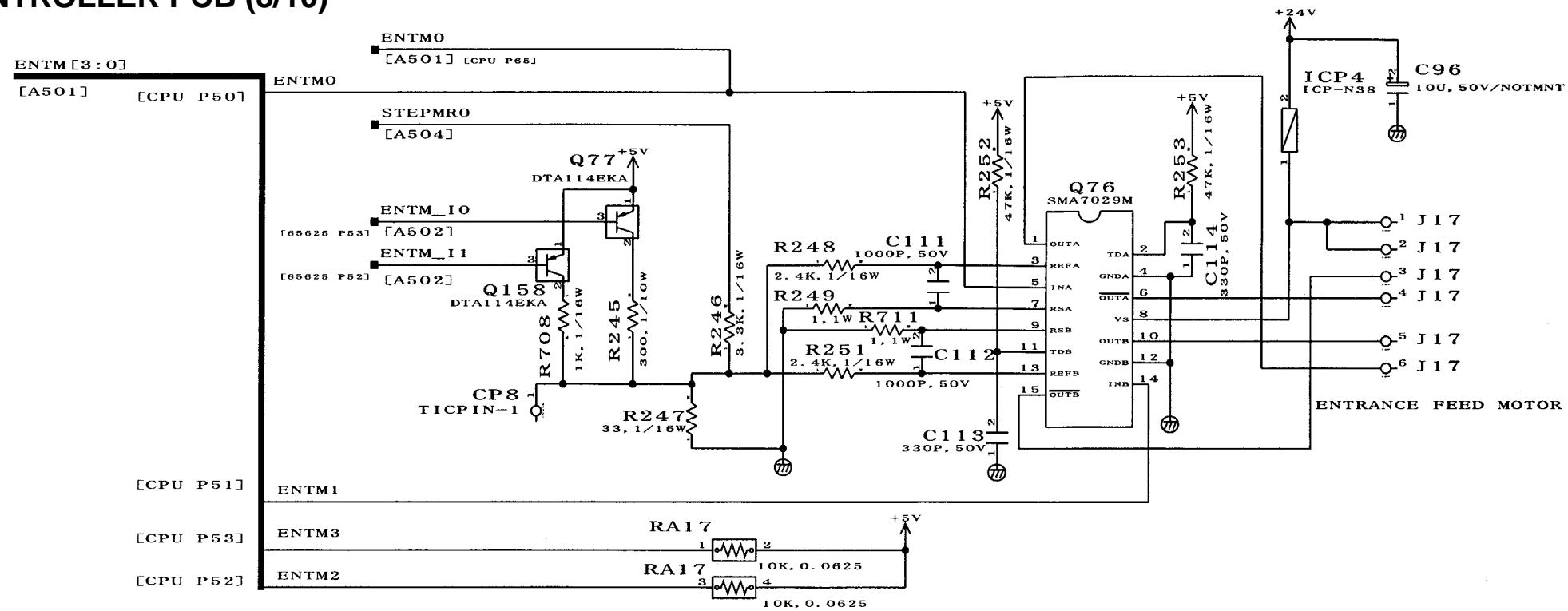

FINISHER CONTROLLER PCB (9/10)

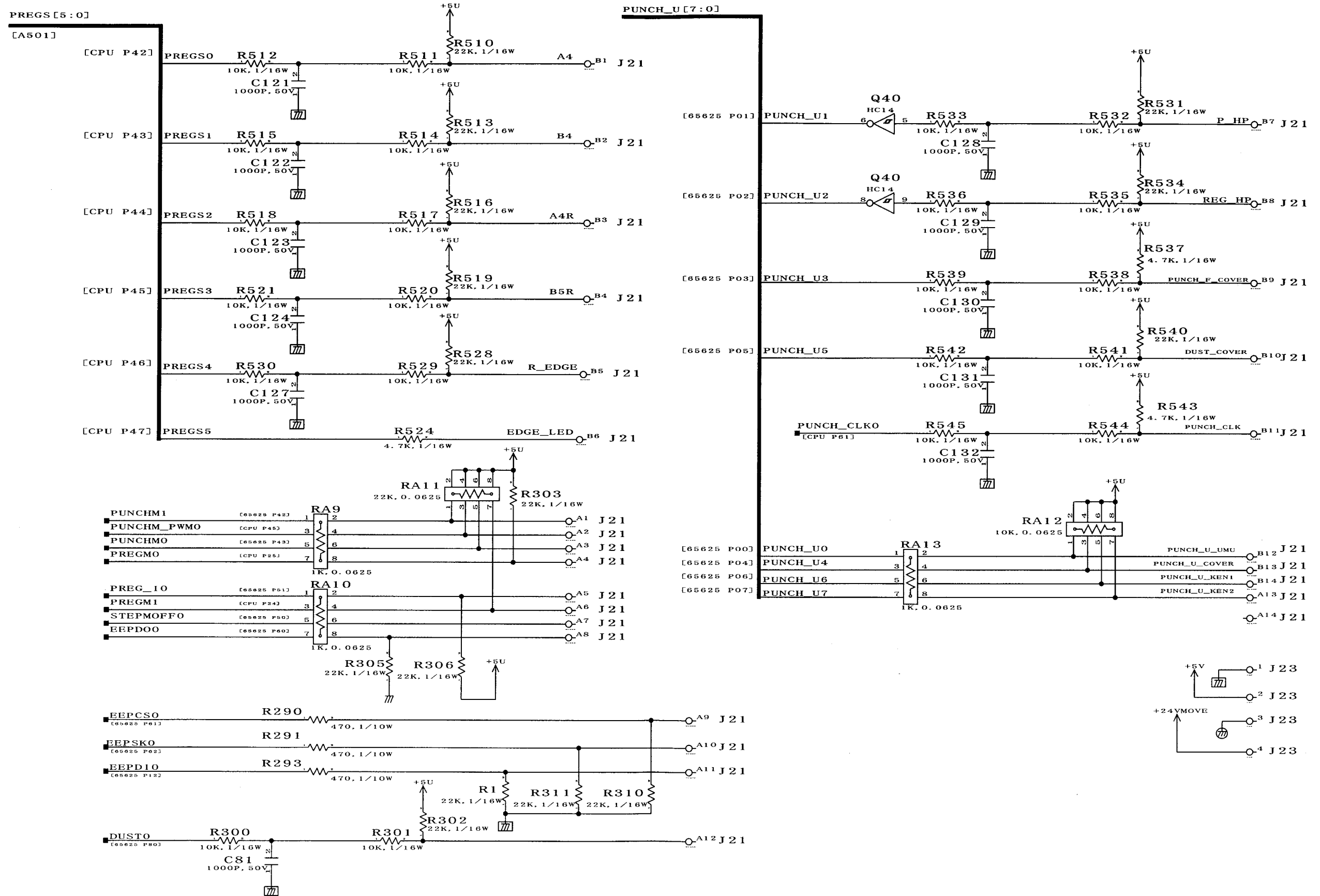

FINISHER CONTROLLER PCB (10/10)

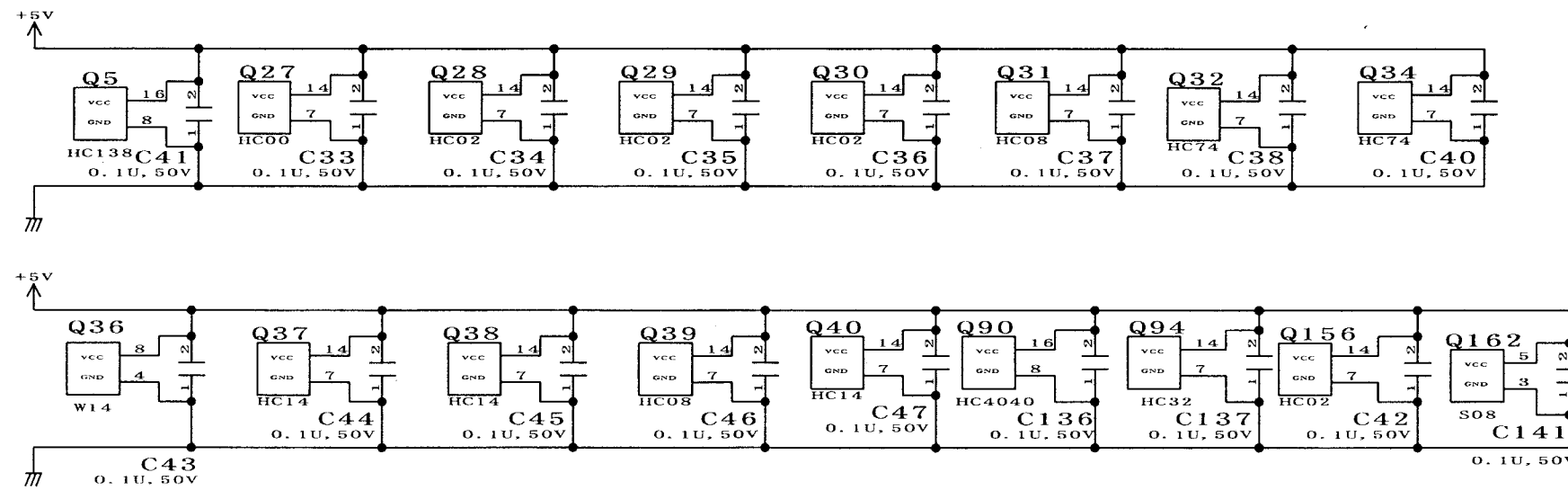

D. SADDLE STITCHER UNIT CIRCUIT DIAGRAM

(1/2)

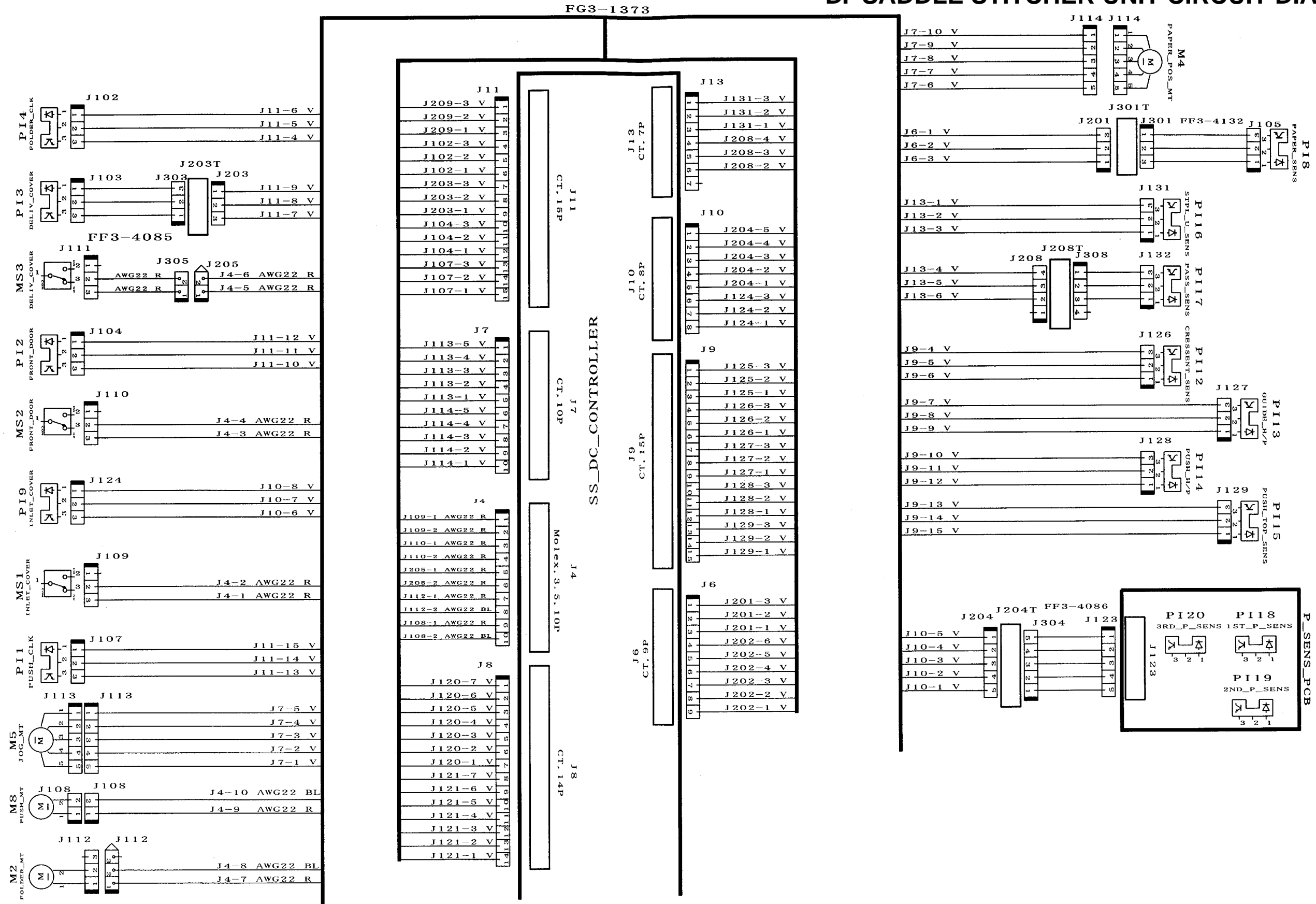

SADDLE STITCHER UNIT CIRCUIT DIAGRAM (2/2)

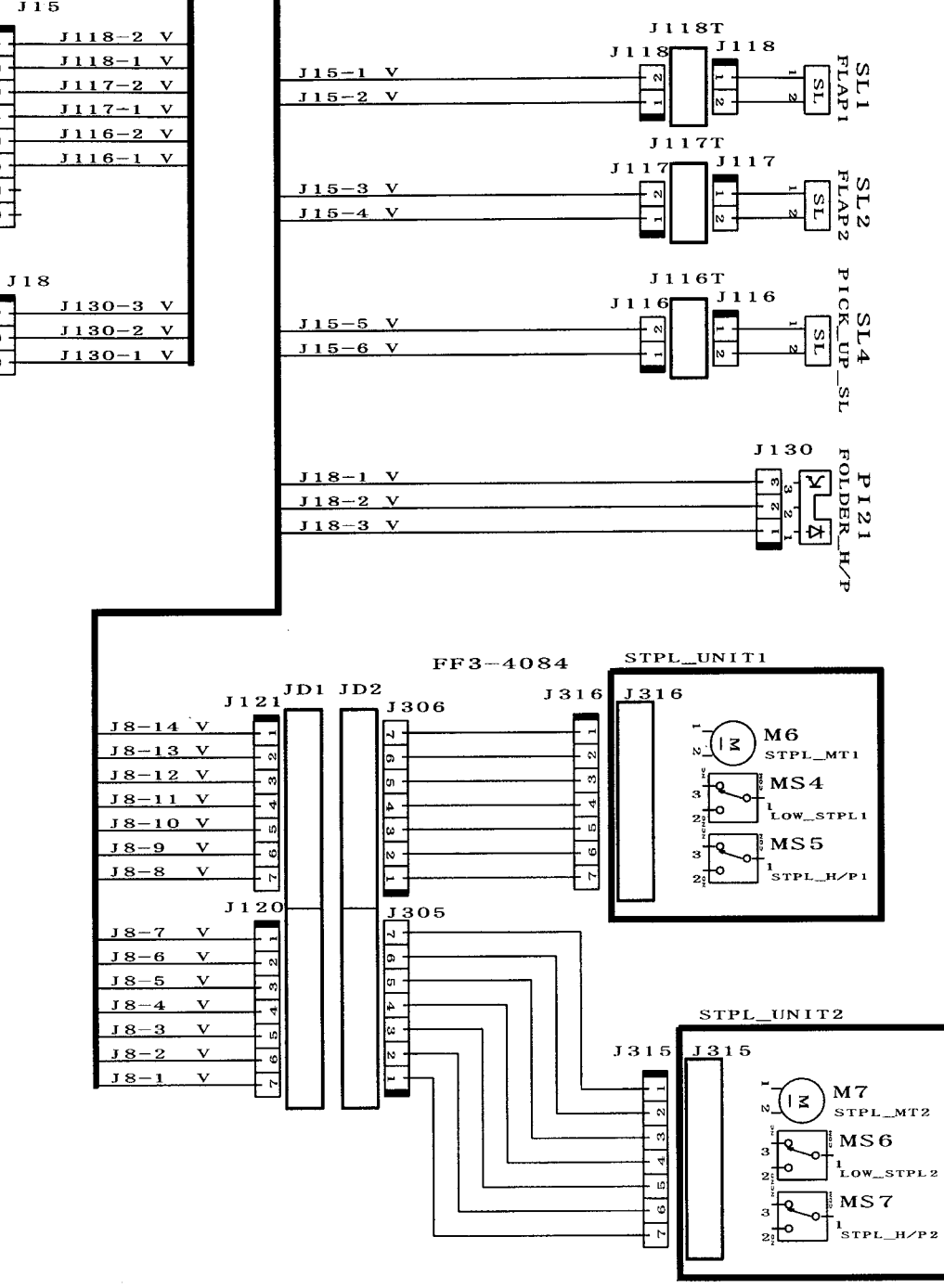
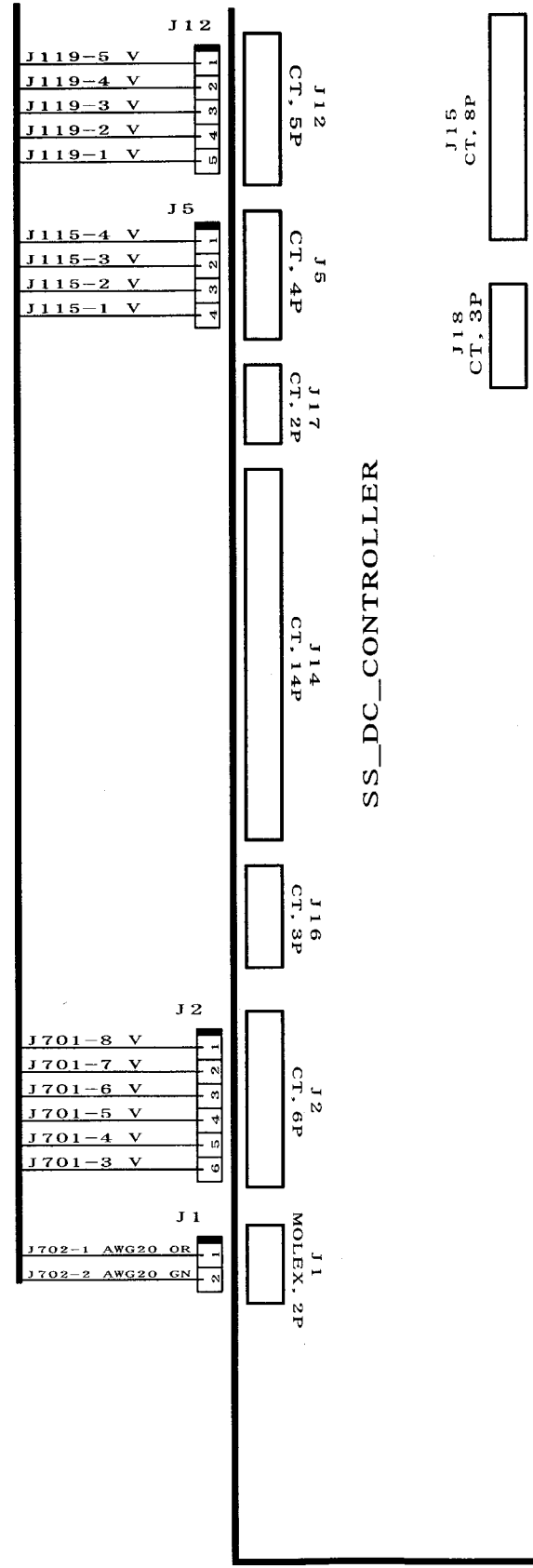
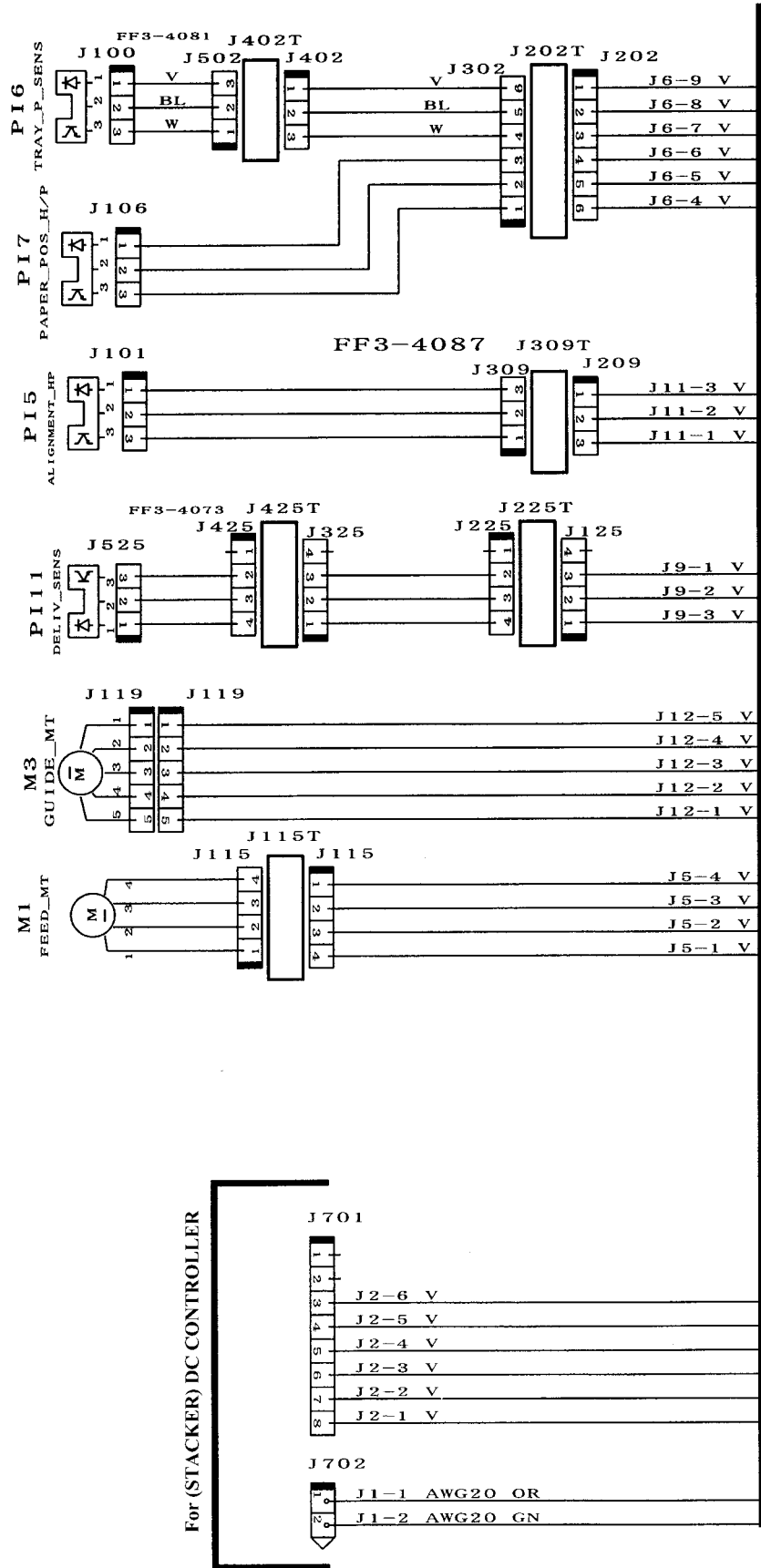

E. SADDLE STITCHER UNIT PCB (1/8)

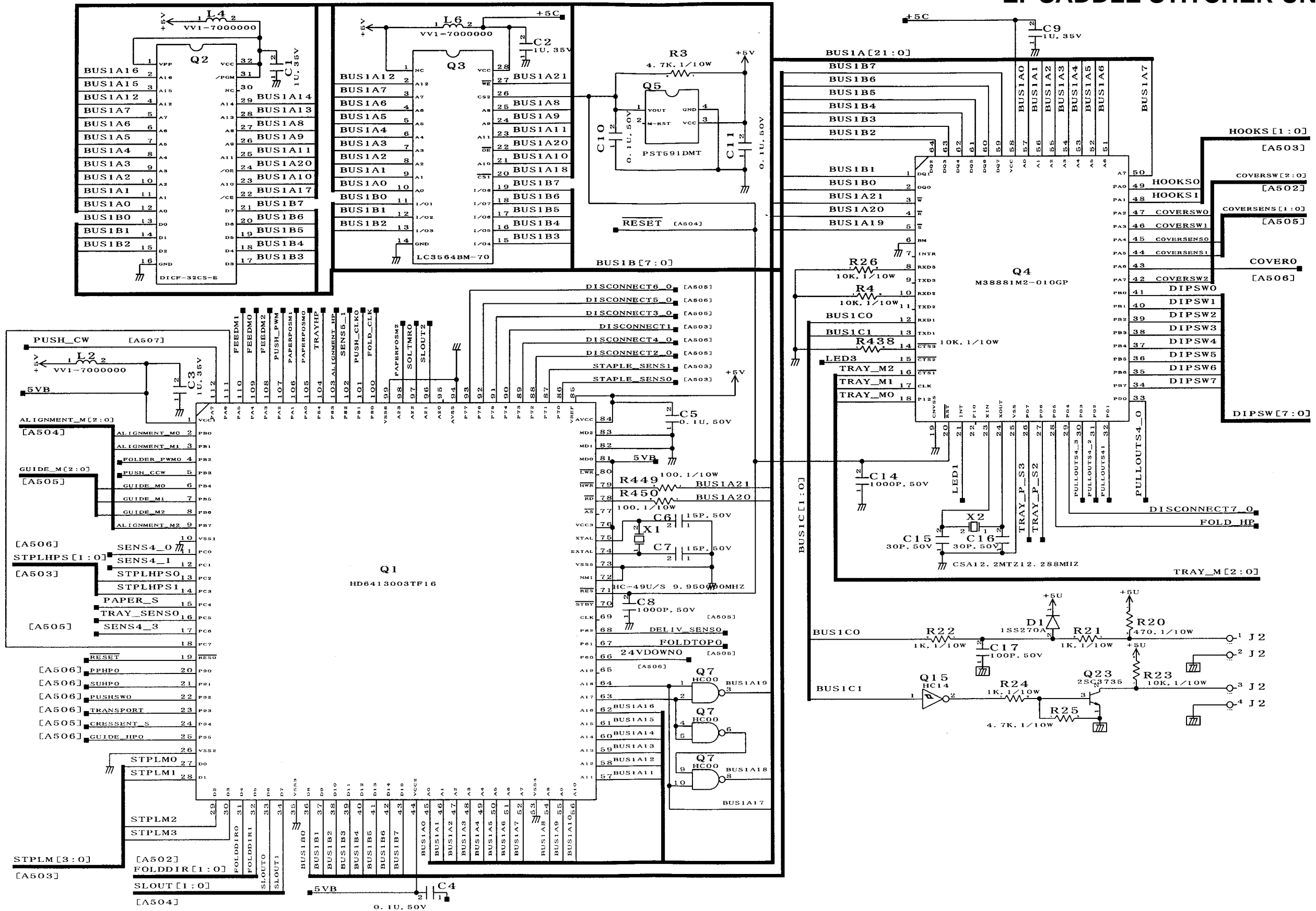

SADDLE STITCHER UNIT PCB (2/8)

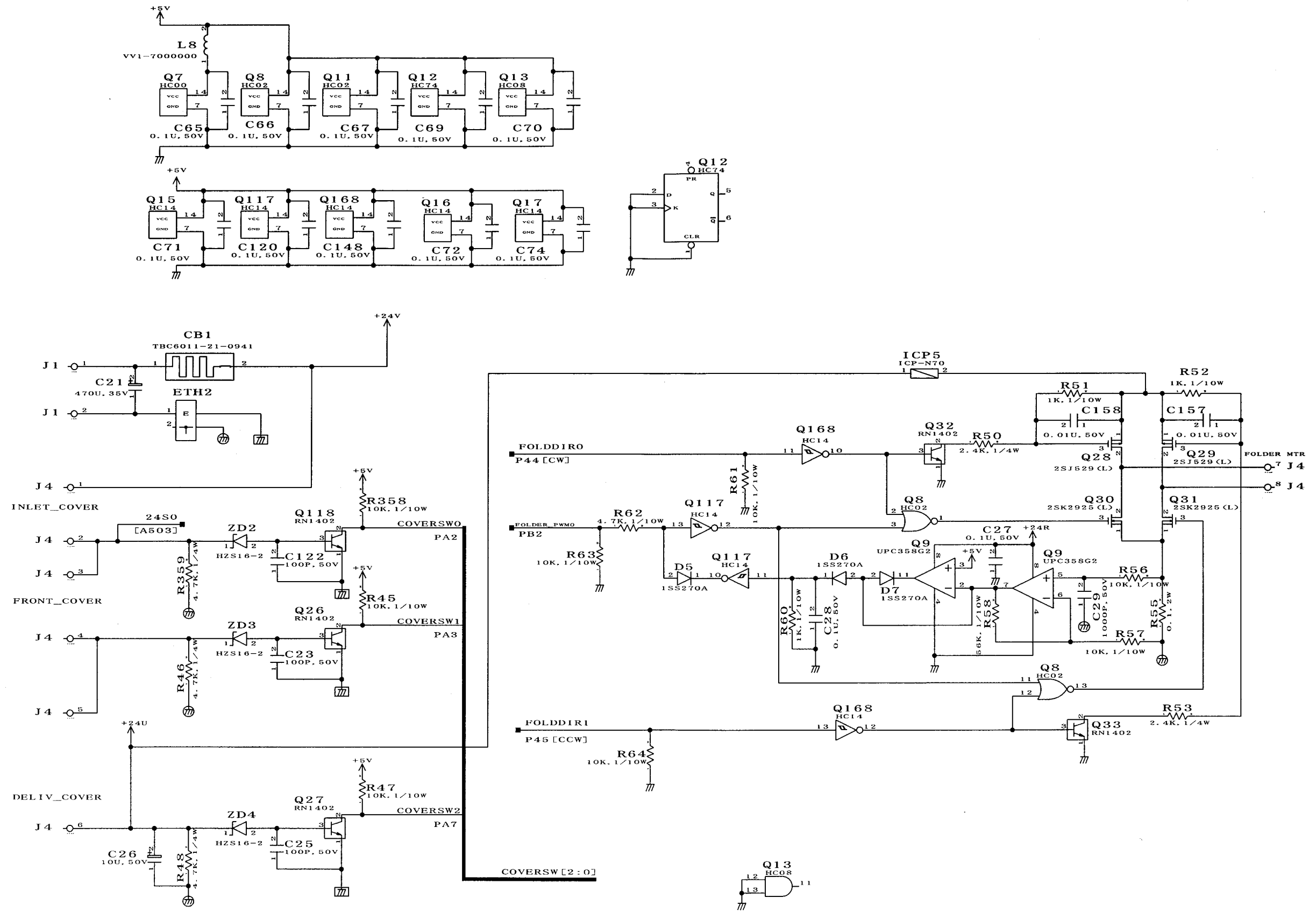

SADDLE STITCHER UNIT PCB (3/8)

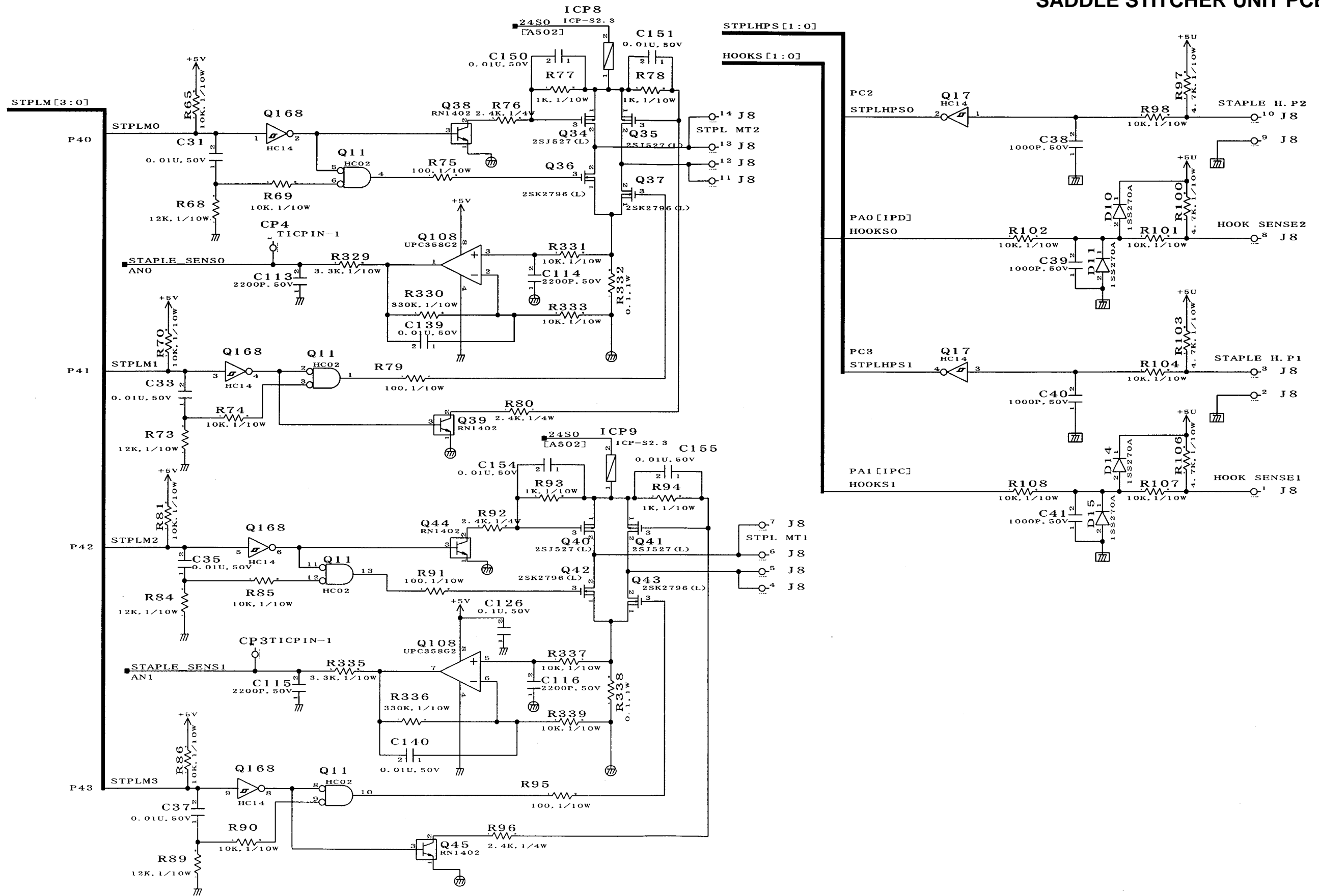

SADDLE STITCHER UNIT PCB (4/8)

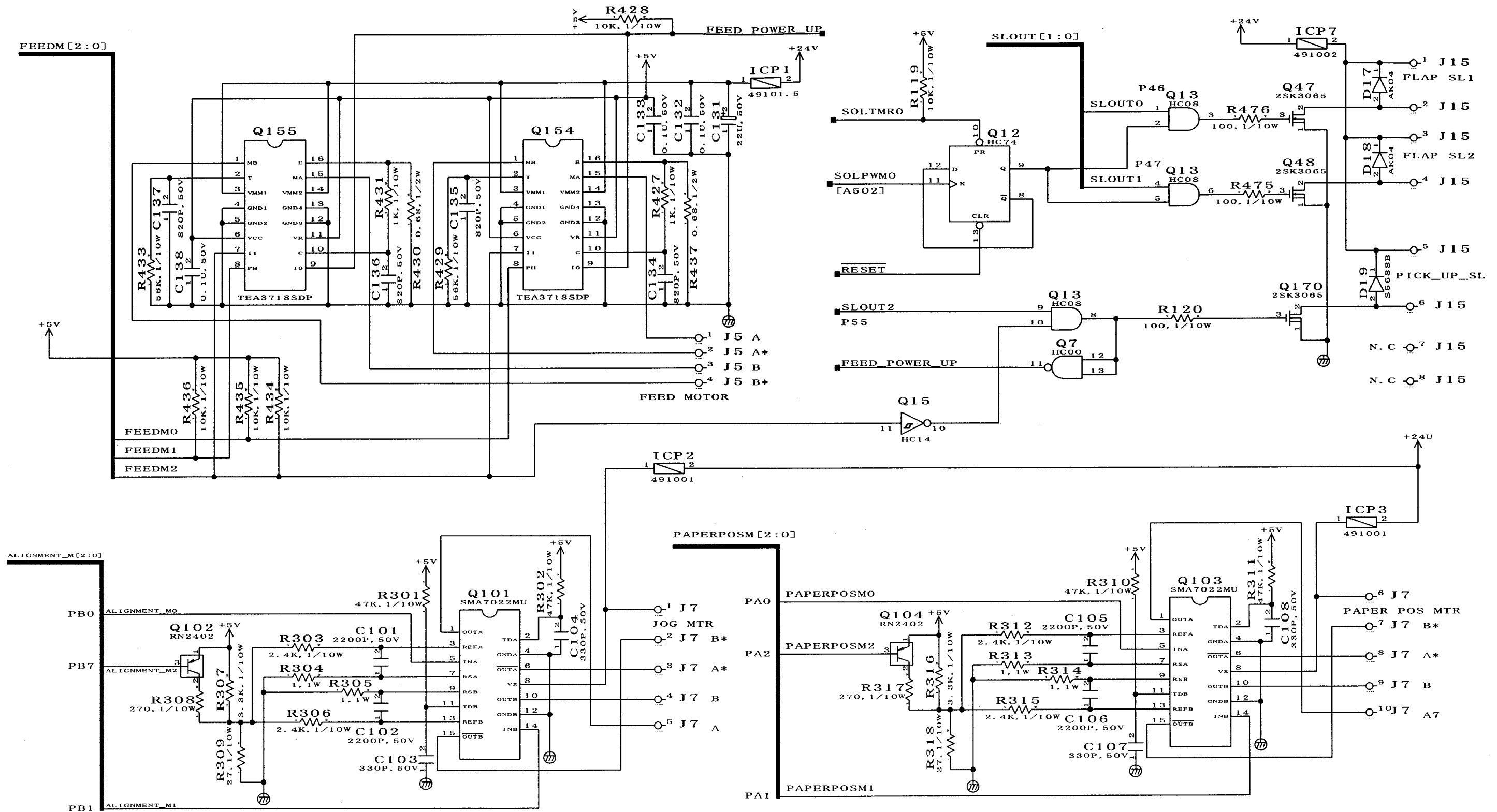

SADDLE STITCHER UNIT PCB (5/8)

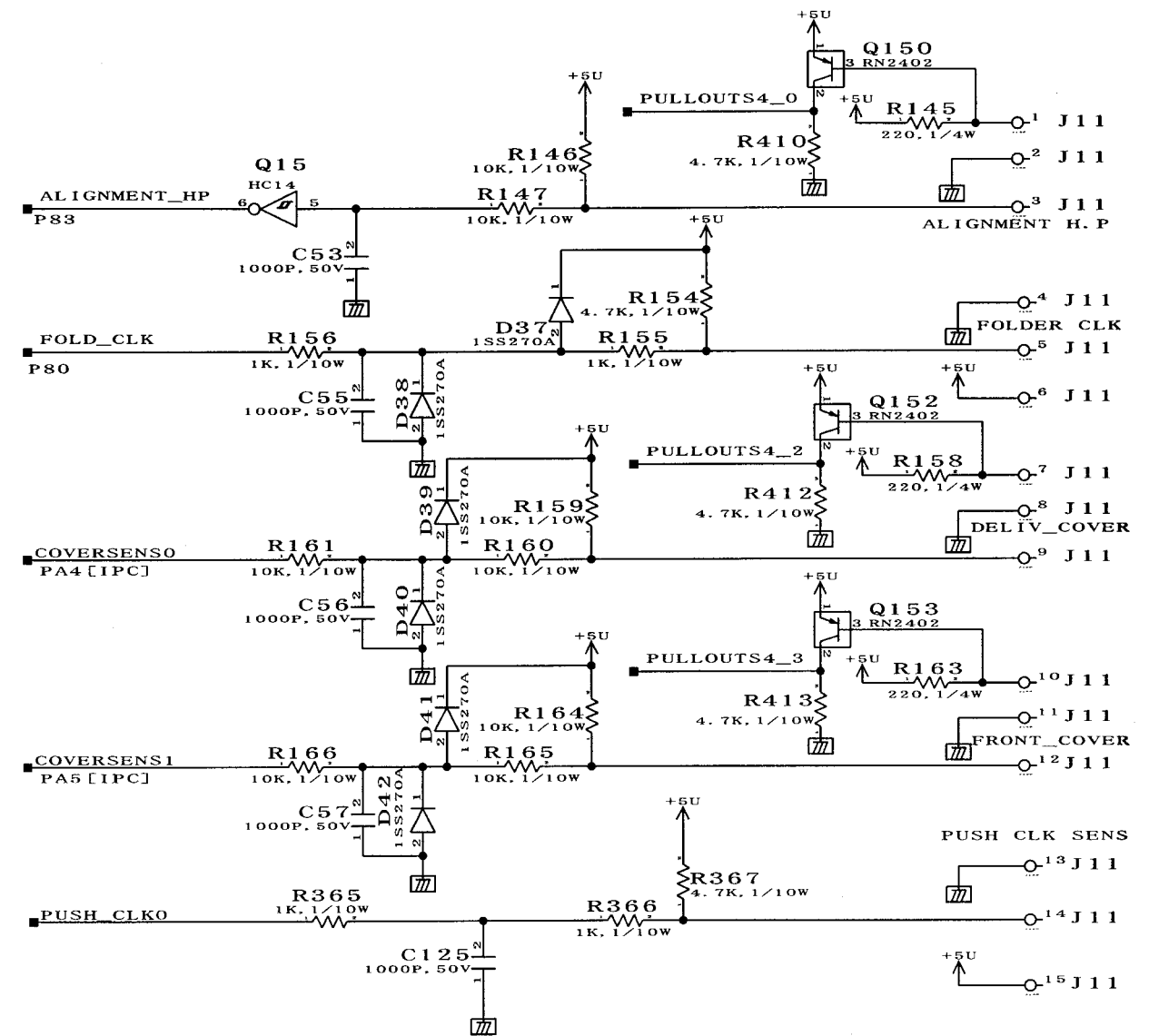
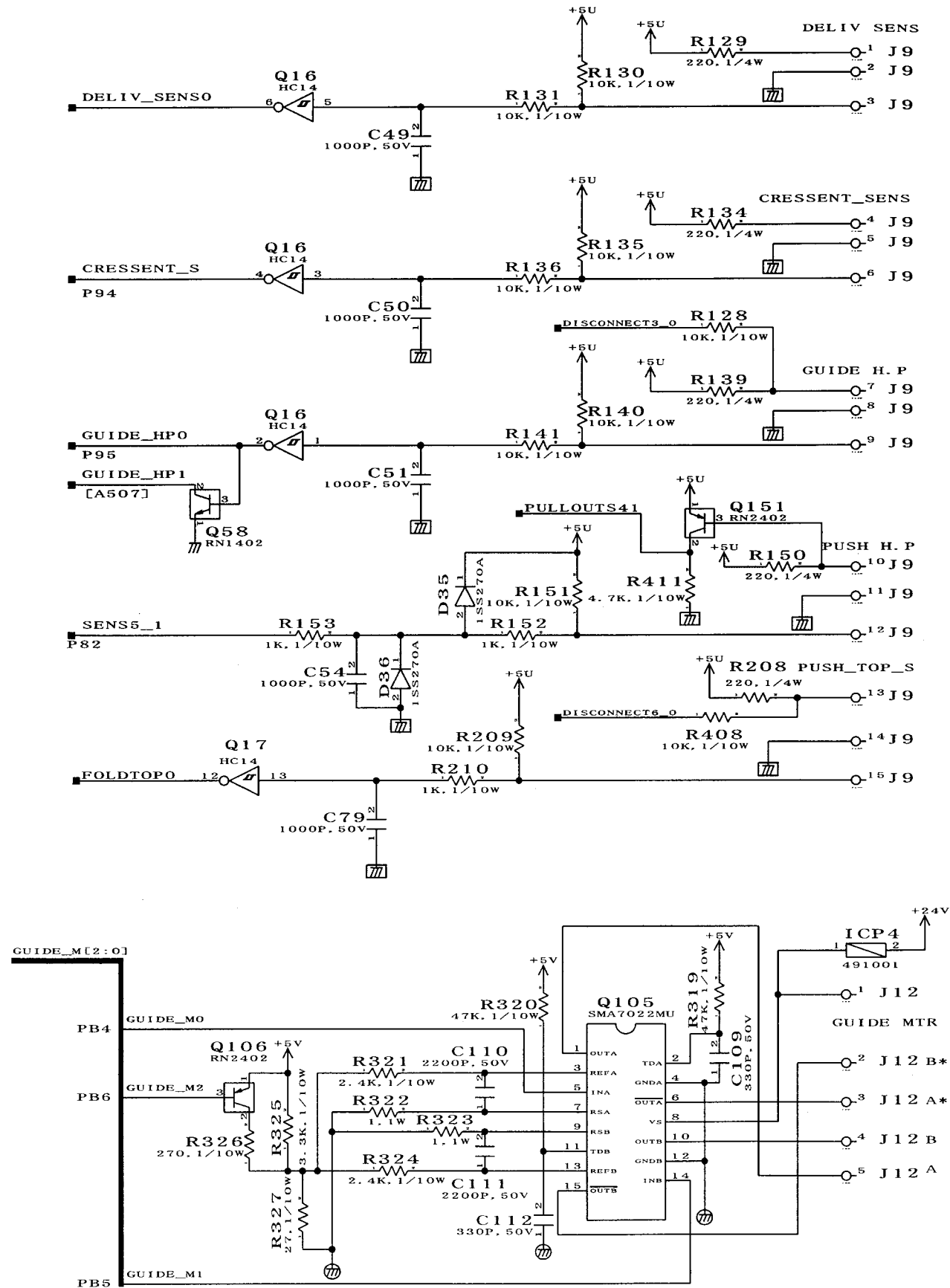

SADDLE STITCHER UNIT PCB (6/8)

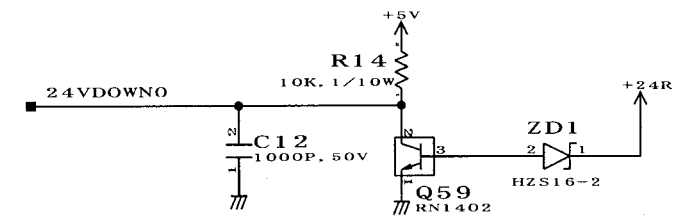
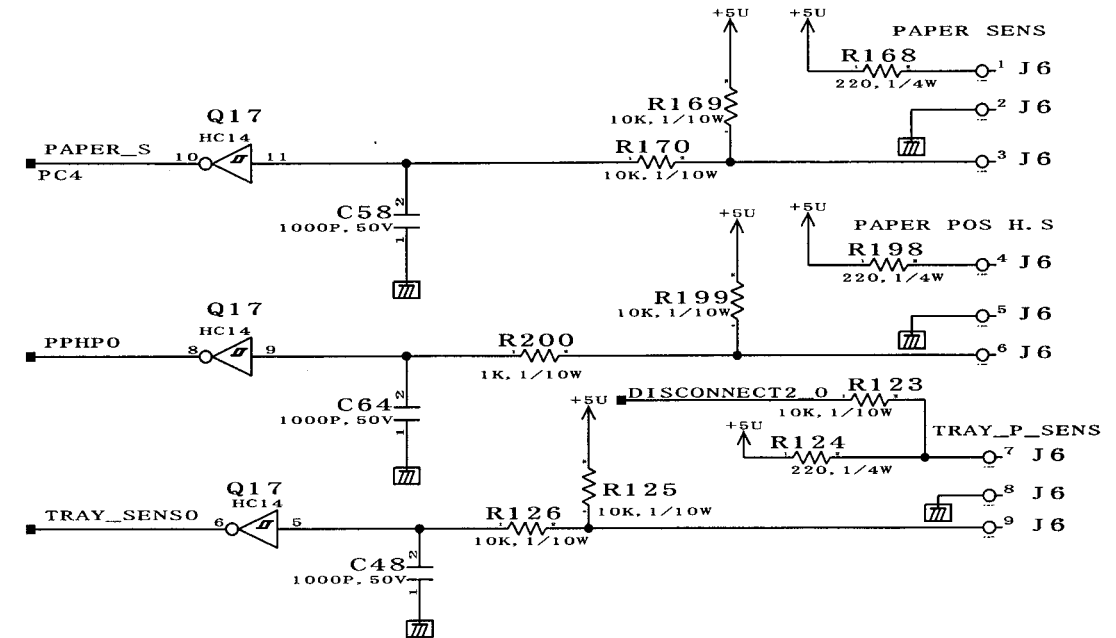
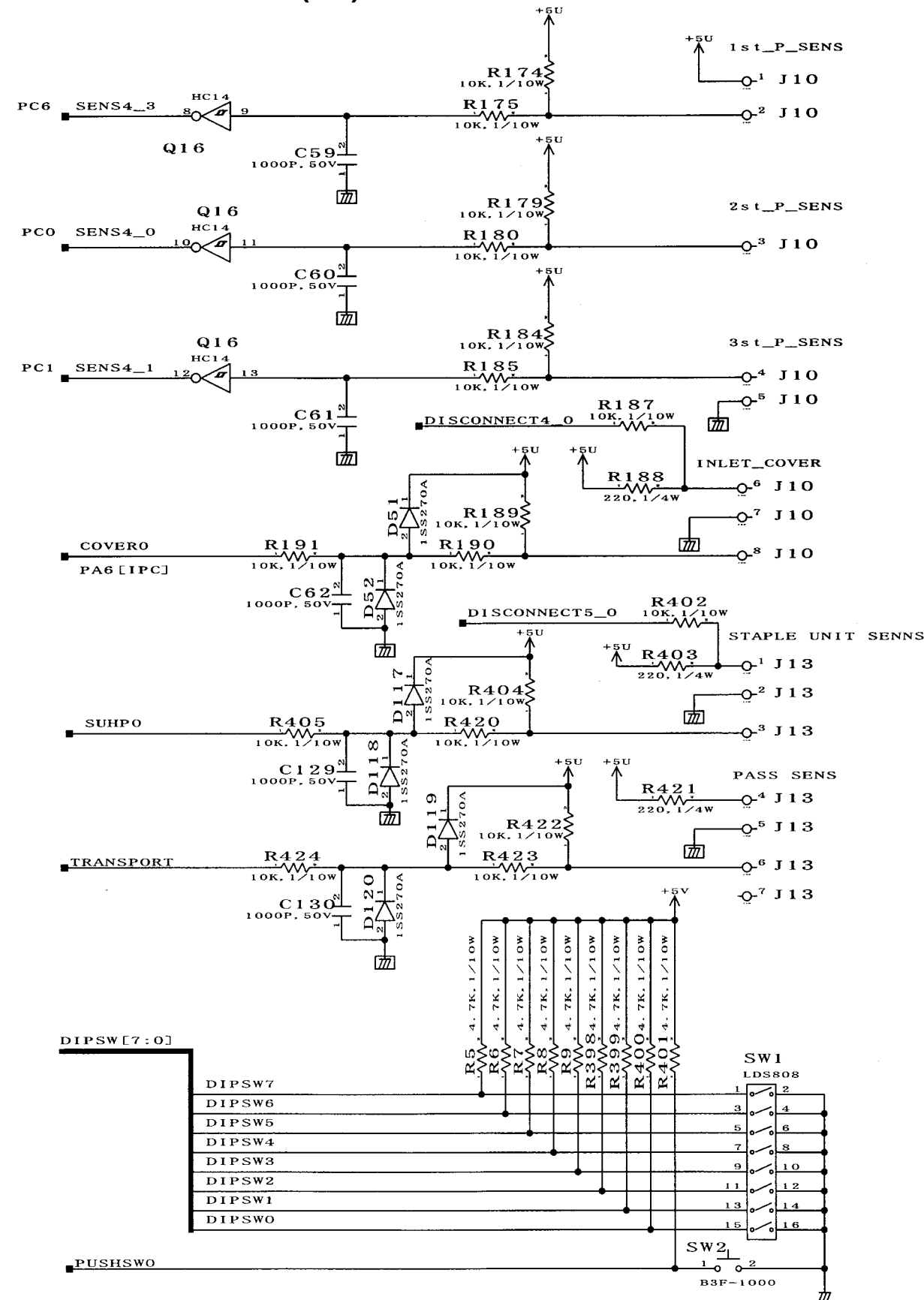

SADDLE STITCHER UNIT PCB (7/8)

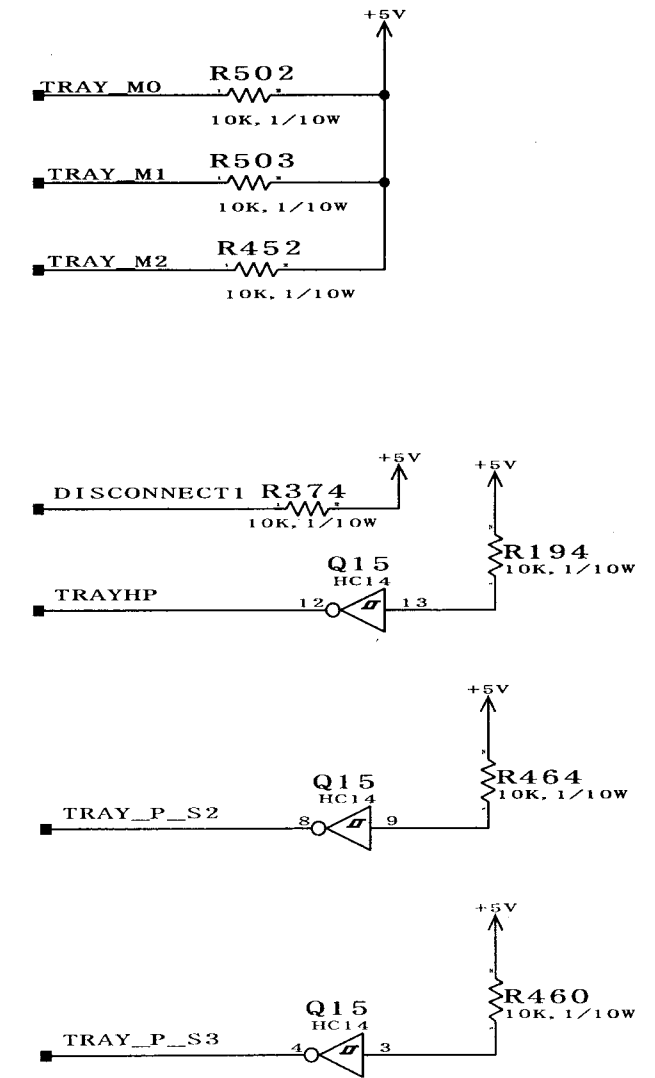
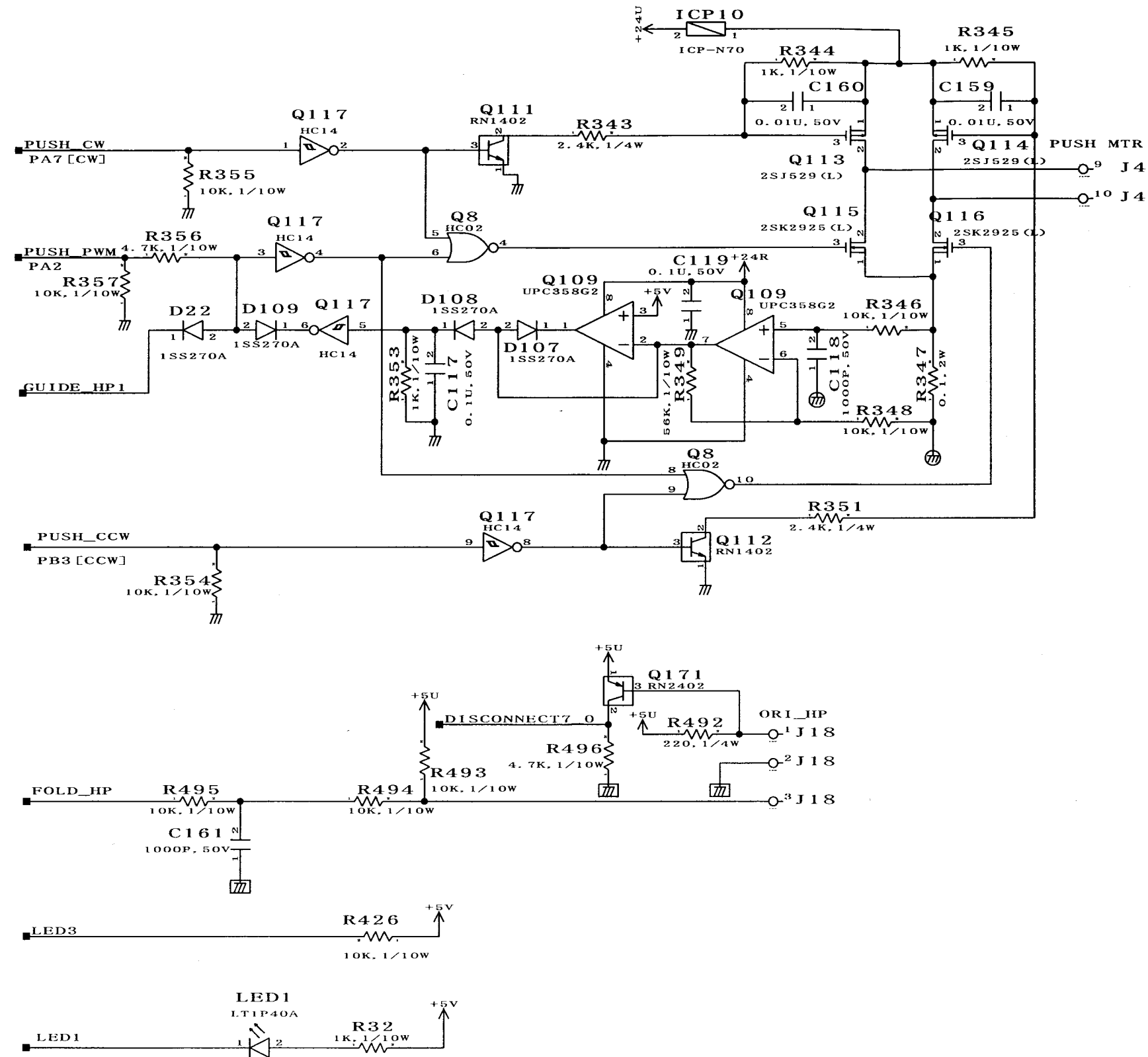

SADDLE STITCHER UNIT PCB (8/8)

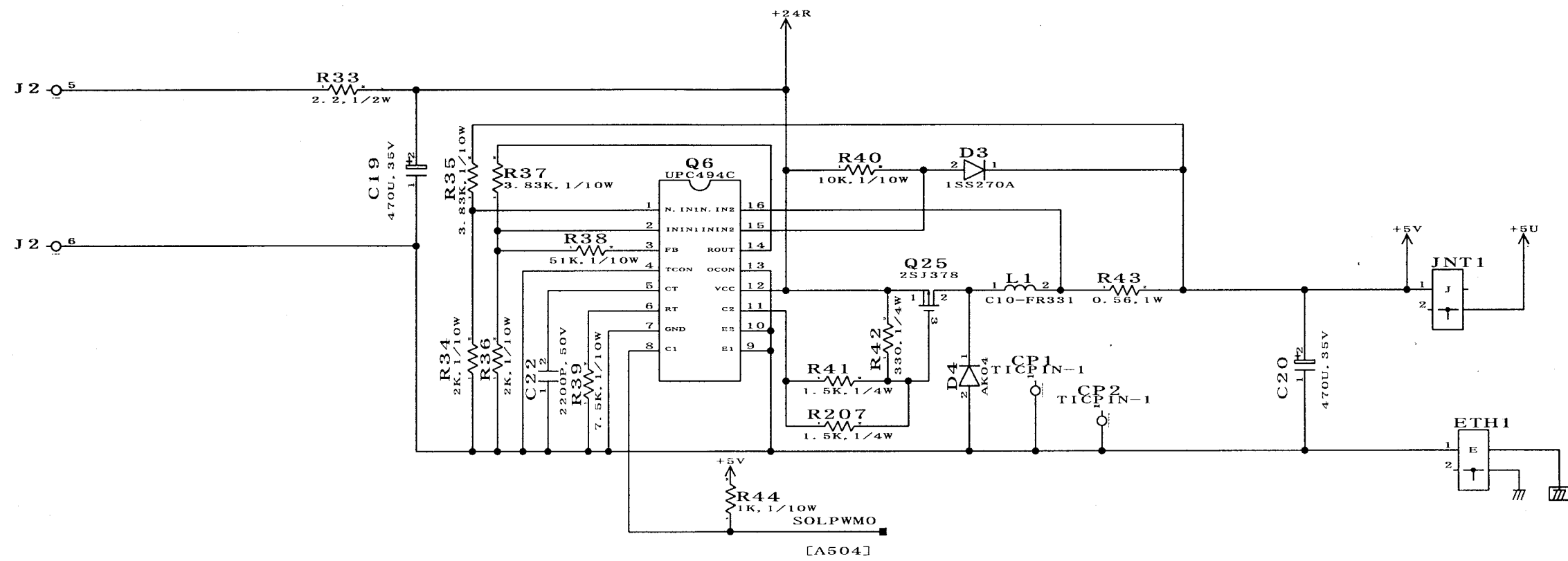

F. PUNCHER UNIT (OPTION) CIRCUIT DIAGRAM (1/1)

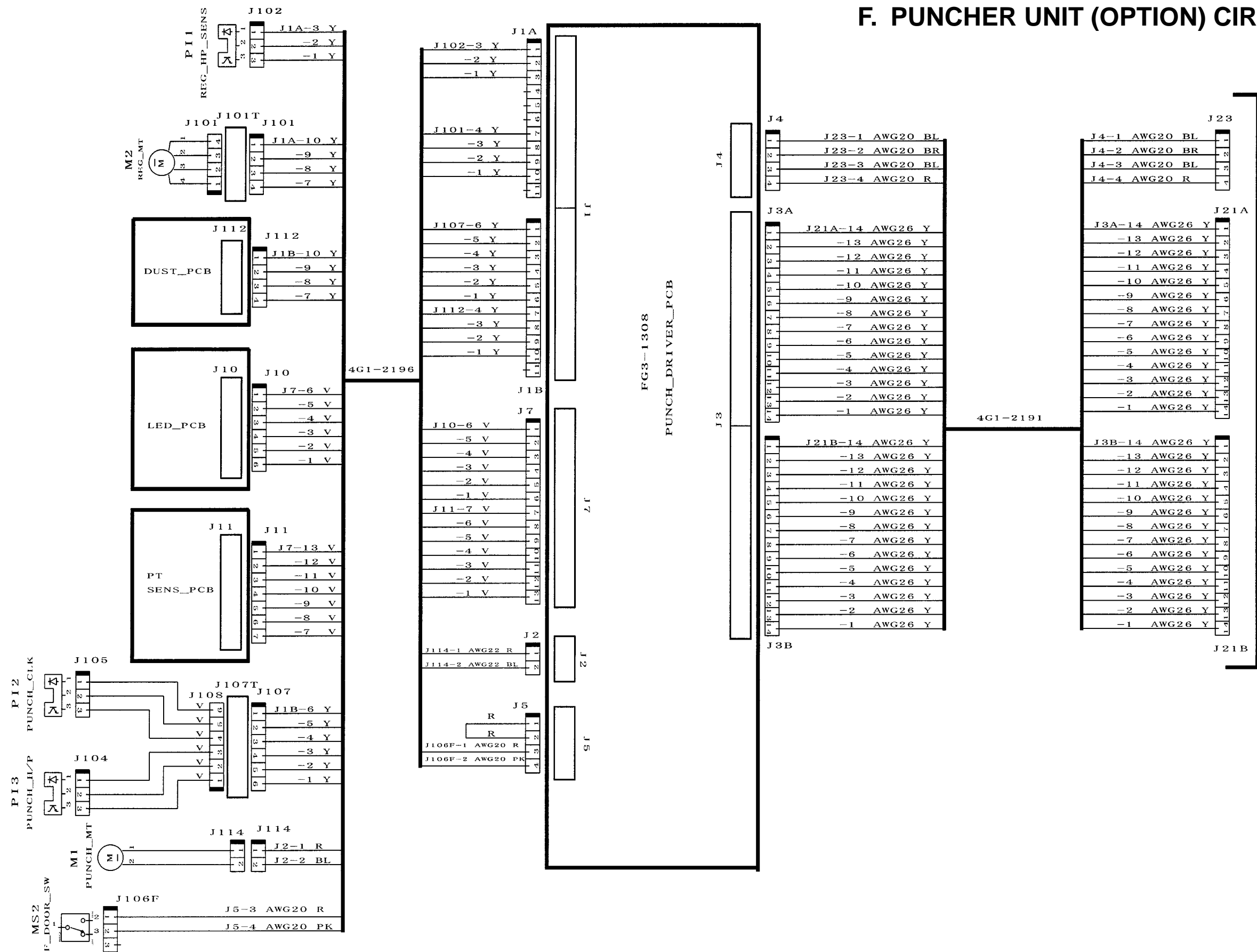

For FINISHER_CONTROLLER_PCB

G. PUNCH DRIVER PCB

(1/2)

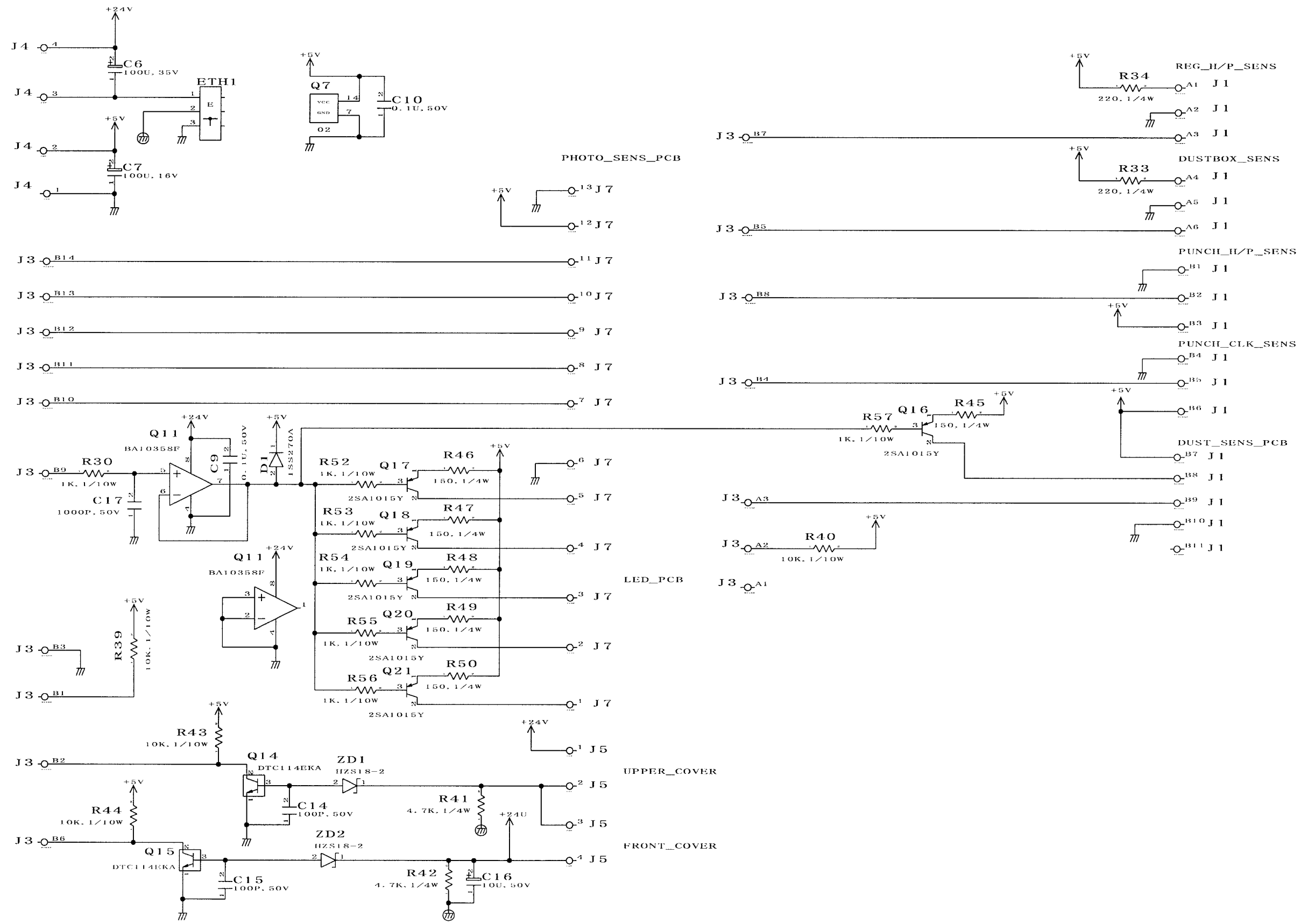

PUNCH DRIVER PCB (2/2)

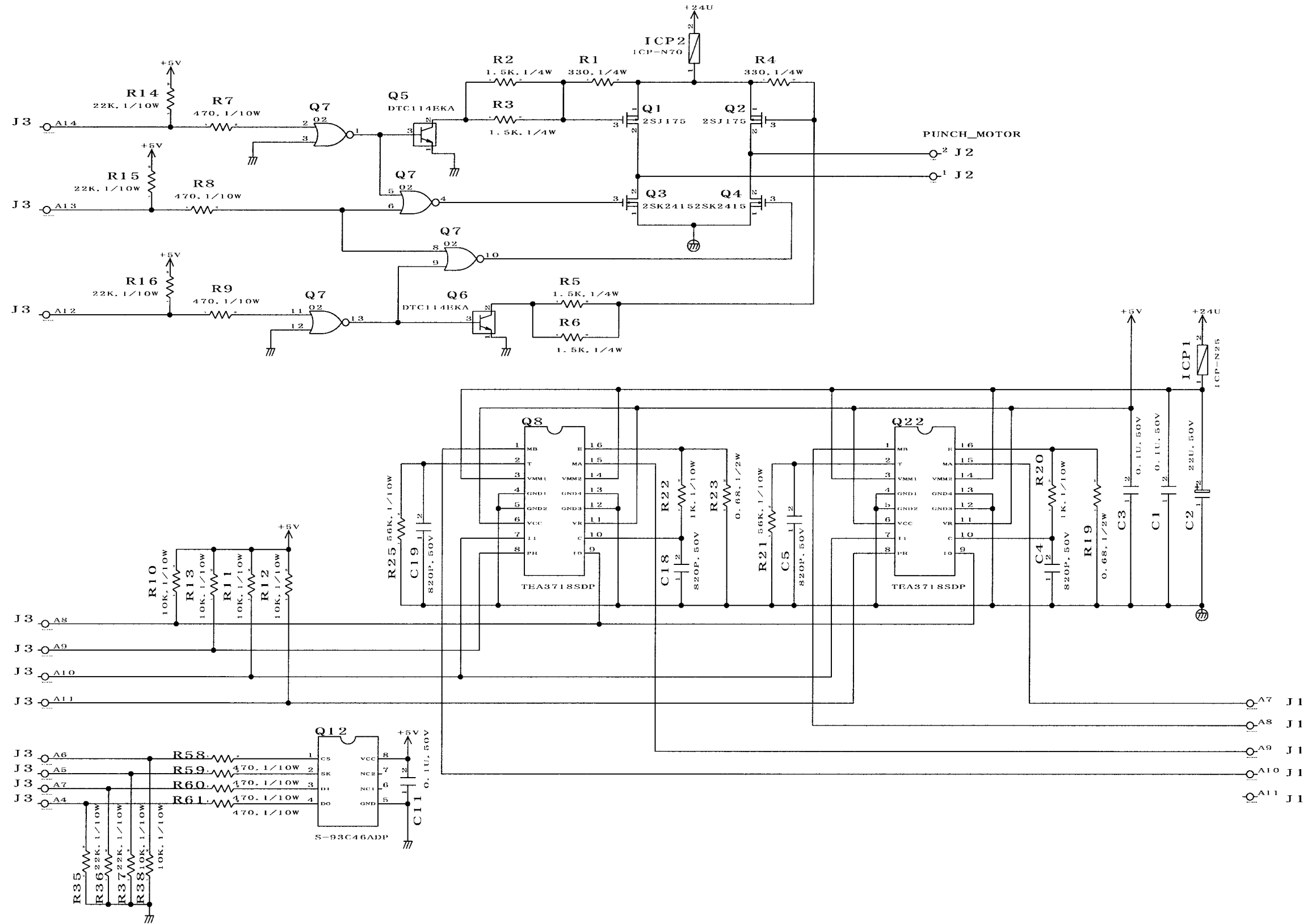

H. SOLVENT AND OIL

No.	Name	Description	Composition	Remarks
1	Cleaner	Cleaning: e.g., glass, plastic, rubber parts, external covers	Hydrocarbon (fluorine family) Alcohol Surface activating agent Water	<ul style="list-style-type: none">· Do not bring near fire.· Procure locally.· Isopropyl alcohol may be substituted.
2	Lubricant	Drive, friction parts, lead cam	Silicone oil	